



**FLORISSANT CITY COUNCIL AGENDA**  
**City Hall**  
**955 rue St. Francois**  
**Monday, June 27, 2022**  
**7:00 PM**  
**Karen Goodwin, MMC/MRCC**



**I. PLEDGE OF ALLEGIANCE**

**II. ROLL CALL OF MEMBERS**

**III. APPROVAL OF MINUTES**

- City Council Meeting minutes of June 13, 2022

**IV. HEARING FROM CITIZENS**

**V. COMMUNICATIONS**

**VI. PUBLIC HEARINGS**

22-06-016 (Ward9) Application Staff Rept Plans	Request to authorize a Special Use Permit to Peach Cobbler Factory to allow for the operation of a sit-down, carry-out restaurant for the property located at 12 Paddock Hills Shopping Center. (Planning and Zoning recommended approval on 6/6/2022)	Nicole Banks
22-06-017 (Ward 9) Application Staff Rpt Plans	Request to amend B-5 ordinance no. 5854 (as amended) to allow for changes in the drive-thru for Panera LLC. located at 2375 N. Hwy 67. (Planning and Zoning recommended approval on 6/6/2022)	Patrick Bennett, PE

**VII. OLD BUSINESS**

**A. BILLS FOR SECOND READING**

9791 Memo	Ordinance vacating a portion of Brown Street at St. Joseph (a paper street).	Mulcahy
--------------	--	---------

**VIII. NEW BUSINESS**

**A. BOARD APPOINTMENTS**

**B. RESOLUTIONS**

1041 Memo	Resolution of the City of Florissant supporting a grant application for a municipal park grant round 23 for relocation and construction of new restroom in St. Ferdinand park.	Council as a whole
--------------	--	--------------------

**C. REQUESTS**

Liquor application	Request for a Full Package Liquor License for Door Dash Essentials LLC located at 1 Paddock Hills Shopping Center, Unit 1D.	Lorene Williams
--------------------	---	-----------------

**D. BILLS FOR FIRST READING**

9793 Application	Ordinance authorizing a transfer of Special Use Permit no. 8603 from Shade Partners, LLC to Shade Restaurant & Bar, LLC for the location of a restaurant and bar located at 1752-1756 N. New Florissant Road.	Siam
9794	Ordinance to amend B-5 ordinance no. 5854 (as amended) to allow for changes in the drive-thru for Panera LLC. located at 2375 N. Hwy 67.	Siam
9795 Memo	Ordinance authorizing the Mayor of the City of Florissant to enter into an agreement with Missouri Highways and Transportation Commission for the Mullanphy Road Project.	Council as a whole
9796 Memo	Ordinance authorizing an appropriation of \$150,000 from the Sewer Lateral Fund to account no. 04-5-08-50050 "Professional Services Sewer Lateral Repairs" for the installation of check valves.	Eagan
E9797 Memo	Ordinance authorizing an appropriation of \$23,000 from the General Revenue Fund to account no. 01-5-40-52150 "Election Expense" to cover the August election expenses.	Eagan
E9798	Ordinance amending Chapter 125.065 "Wage Increase and Schedule", section B "Police Department Employees" by deleting "Academy Recruit".	Eagan

E9799	Ordinance amending ordinance no. 8747 establishing a grade and step schedule for full time uniformed employees and dispatchers by removing the position of “student police officer”.	Eagan
E9800 Memo	Ordinance authorizing a transfer of \$111,000 from Escrow Fund Acct 13-20301 "Forfeiture Escrow" to General Fund Acct 01-4-34511 "Police Forfeiture Revenue" and an appropriation of \$111,000 to General Fund Acct 01-5-49-61000 "Police Forfeiture Expenditures" for various police expenditures.	Eagan
E9801 Memo	Ordinance to increase Public Safety Revenue account no. 17-4-17310 “Insurance Proceeds” with funds received in the amount of \$27,343 and an appropriation of the same amount to account no. 17-5-17-610000 “Capital Additions-Vehicles” for the purchase of a 2022 Dodge Durango.	Eagan

**IX. COUNCIL ANNOUNCEMENTS**

**X. MESSAGE FROM THE MAYOR**

**XI. ADJOURNMENT**

**THIS AGENDA WAS POSTED ON THE BULLETIN BOARD IN THE LOBBY AT CITY HALL AND ON THE CITY WEBSITE AT FLORISSANTMO.COM ON JUNE 24, 2022 BY 12:00 PM.**

**ANY ONE WISHING TO ATTEND THE COUNCIL MEETING WHO HAS SPECIAL NEEDS SHOULD CONTACT THE CITY CLERK BY NOON ON MONDAY, JUNE 27, 2022.**

# CITY OF FLORISSANT



## COUNCIL MINUTES

June 13, 2022

The Florissant City Council met in regular session at Florissant City Hall, 955 rue St. Francois on Monday, June 13, 2022 at 7:00 p.m. with Council President Schildroth presiding. The Chair asked everyone in attendance to stand and join in reciting the Pledge of Allegiance.

On Roll Call the following Councilmembers were present: Parson, Siam, Harris, Manganelli, Eagan, Caputa, Schildroth, Mulcahy, and Pagano. Also present was Mayor Timothy Lowery, City Clerk Karen Goodwin, and City Attorney John Hessel. A quorum being present the Chair stated that the Council Meeting was in session for the transaction of business.

Councilman Manganelli moved to approve City Council Minutes of May 23, 2022, seconded by Harris. Motion carried.

The next item on the Agenda was *Special Presentations*.

A Resolution of the House of Representatives was presented to City Attorney John Hessel which noted his receipt of the 2022 ICON award for his exemplary career within the St. Louis region. John Hessel thanked everyone for the privilege and for the recognition of what he has done and noted his honor for representing his hometown for many years.

The next item on the Agenda was *Hearing from Citizens* of which there were none.

The Chair stated that the next item on the agenda was *Second Readings*.

Councilman Eagan moved that Bill No. 9782 an Ordinance to approve a B-5 "Planned Commercial District" located at 540 Howdershell Lot "B" to allow for a car sales office for CarGroup Holdings, LLC be read for a second time, seconded by Pagano. Motion carried and Bill No. 9782 was read for a second time.

Councilman Eagan moved that Bill No. 9782 be read for a third time, seconded by Schildroth. Motion carried and Bill No. 9782 was read for a third time and placed upon its passage. Before the final vote all interested persons were given an opportunity to be heard.

Being no persons who wished to speak, on roll call the Council voted: Parson yes, Siam yes, Harris yes, Manganelli yes, Eagan yes, Caputa yes, Schildroth yes, Mulcahy yes, and Pagano yes.

Whereupon the Chair declared Bill No. 9782 to have passed and become Ordinance No. 8793.

31 Councilman Siam moved that Bill No. 9783 an Ordinance to amend B-5 Ordinance No. 6669 to  
32 add “Equipment Rental, Home, and General” as a permitted use located at 13939 New Halls Ferry Road,  
33 be read for the second time, seconded by Harris. Motion carried and Bill No. 9783 was read for a second  
34 time.

35 Councilman Siam moved that Bill No. 9783 be read for a third time, seconded by Mulcahy.  
36 Motion carried and Bill No. 9783 was read for a third time and placed upon its passage. Before the final  
37 vote all interested persons were given an opportunity to be heard.

38 Being no persons who wished to speak, on roll call the Council voted: Parson yes, Siam yes,  
39 Harris yes, Manganelli yes, Eagan yes, Caputa yes, Schildroth yes, Mulcahy yes, and Pagano yes.

40 Whereupon the Chair declared Bill No. 9783 to have passed and become Ordinance No. 8794.

41 Councilman Schildroth moved to accept Substitute Bill No. 9784, seconded by Parson. Motion  
42 carried.

43 Councilman Schildroth moved that Bill No. 9784 an Ordinance to approve a Special Use Permit  
44 to allow for a Wine Bar in a HB “Historic Business District” located at 150 Washington, be read for the  
45 second time, seconded by Siam.

46 Councilman Schildroth noted the concerns of residents were taken into consideration for the  
47 Substitute Bill. Motion carried and Bill No. 9784 was read for a second time.

48 Councilman Schildroth moved that Bill No. 9784 be read for a third time, seconded by  
49 Manganelli. Motion carried and Bill No. 9784 was read for a third time and placed upon its passage.  
50 Before the final vote all interested persons were given an opportunity to be heard.

51 Being no persons who wished to speak, on roll call the Council voted: Parson yes, Siam yes,  
52 Harris yes, Manganelli yes, Eagan yes, Caputa yes, Schildroth yes, Mulcahy yes, and Pagano yes.

53 Whereupon the Chair declared Bill No. 9784 to have passed and become Ordinance No. 8795.

54 Councilman Harris moved that Bill No. 9788 an Ordinance to amend Title III “Traffic Code”  
55 Schedule III “Stop Intersections”, Table IIIA “One Way Stops” by adding Bobolink at Flamingo and  
56 Chickadee at Flamingo, be read for the second time, seconded by Caputa. Motion carried and Bill No.  
57 9788 was read for a second time.

58 Councilman Harris moved that Bill No. 9788 be read for a third time, seconded by Mulcahy.  
59 Motion carried and Bill No. 9788 was read for a third time and placed upon its passage. Before the final  
60 vote all interested persons were given an opportunity to be heard.

61 Being no persons who wished to speak, on roll call the Council voted: Parson yes, Siam yes,  
62 Harris yes, Manganelli yes, Eagan yes, Caputa yes, Schildroth yes, Mulcahy yes, and Pagano yes.

63 Whereupon the Chair declared Bill No. 9788 to have passed and become Ordinance No. 8796.

64 Councilman Harris moved that Bill No. 9789 an Ordinance to amend Title III “Traffic Code”  
65 Schedule III “Stop Intersections”, Table IIIB “Two Way Stops” by adding Swan at Flamingo, be read for  
66 the second time, seconded by Eagan. Motion carried and Bill No. 9789 was read for a second time.

67 Councilman Harris moved that Bill No. 9789 be read for a third time, seconded by Caputa. Motion  
68 carried and Bill No. 9789 was read for a third time and placed upon its passage. Before the final vote all  
69 interested persons were given an opportunity to be heard.

70 Being no persons who wished to speak, on roll call the Council voted: Parson yes, Siam yes,  
71 Harris yes, Manganelli yes, Eagan yes, Caputa yes, Schildroth yes, Mulcahy yes, and Pagano yes.

72 Whereupon the Chair declared Bill No. 9789 to have passed and become Ordinance No. 8797.

73 The Chair stated that the next item on the agenda was *Board Appointments*.

74 Councilwoman Pagano made a motion to accept the mayor’s appointment of John Jaworski,  
75 13651 New Halls Ferry, to the Veteran’s Commission as a member from Ward 9 with a term expiring on  
76 6/13/2025. Seconded by Schildroth, motion carried.

77 Councilman Schildroth made a motion to accept the mayor’s appointment of Brandon Brookfield,  
78 155 Brower Court, to the Youth Advisory Commission as a member from Ward 5 with a term expiring  
79 on 6/13/2025. Seconded by Caputa, motion carried.

80 The Chair stated that the next item on the agenda was *Requests*.

81 Councilman Manganelli moved to refer the Request to transfer Special Use Permit no. 5580 from  
82 Delor Distributing, Inc d/b/a Cannoli’s Sicilian Cuisine to 2.0 Restaurant for the location and operation  
83 of a restaurant located at 462 N. Highway 67 to the Planning and Zoning Commission for  
84 recommendation, seconded by Pagano.

85 Councilman Mulcahy asked for clarification from council regarding the Special Use permit. City  
86 Attorney Hessel noted the original Special Use permit was granted for a sit-down, carry-out restaurant  
87 and not for a comedy show or any additional shows which results in the applicant needing to take the  
88 Special Use Request to the Planning and Zoning Commission. Motion carried.

89 Councilman Parson moved accept the Request to approve a Full Liquor by the Drink license for  
90 Plush Lounge for a restaurant/bar located at 12667 New Halls Ferry Road, seconded by Pagano.

91 Councilman Parson made a motion to suspend the rules to speak with the petitioner, seconded by  
92 Pagano. Motion carried.

93 Councilman Parson noted an incident on Memorial Day weekend which has influenced decision  
94 for him to not support a liquor license at this restaurant. Prince Koroma clarified the event was  
95 unfortunate and he did not play a part in the patron who was walking by and came by while intoxicated  
96 and uninvited. Councilwoman Pagano noted her agreement with Councilman Parson, she asked why the

97 bouncer felt the need to search family and friends. Mr. Koroma clarified this was a friend who would  
98 lock the door and open it for any friends or family who were over the age of 21 to come in. He noted this  
99 was not a soft opening, but just friends and family who were in town and hoping to have the restaurant  
100 open for them to visit. Councilwoman Pagano questioned why a restaurant/bar would need two officers  
101 at the door while other restaurant/bars in the area do not have officers. Mr. Koroma noted he has done  
102 research and witnessed many incidents and fights break out at restaurants/bars in the area and he wants  
103 to have police presence in the parking lot as a preventative measure. Chief Fagan, Police Chief, stated  
104 about 60 to 70 people who were presented and the person who was assaulted noted there were likely  
105 closer to 100 people present. Chief Fagan noted the man who is being claimed to have wandered by was  
106 formally invited to the event when the assault occurred. He stated there was alcohol inside the building  
107 without the liquor license being issued. Chief Fagan noted property damage occurred to businesses  
108 around Plush Lounge in addition to the assault. City Attorney Hessel stated the request to not allow  
109 alcohol would be an amendment to the Special Use Permit and noted two issues. One issue the transfer  
110 of the Special Use which allowed Jay's Lounge to be run as a restaurant and bar, not a nightclub, which  
111 would require him to go back to the Planning and Zoning Commission, and whether or not he complies  
112 with the current Special Use Permit. The second issue which the granting or denial of the liquor license,  
113 this would allow him to operate a restaurant without the bar portion and serving alcohol. Mr. Hessel noted  
114 the City Council needs to address problems when they arrive rather than waiting to address them later.  
115 Councilman Eagan stated he has accepted everything that was said from the beginning. He stated the  
116 establishment was labelled for hookah with his social media reflecting the same information and  
117 contradicted his initial requests to the council. Councilman Eagan noted in a visit to the establishment,  
118 he witnessed cocktail tables in front of a DJ booth, which does not depict a restaurant and noted the  
119 flooring around the area looks more like a dance floor in a nightclub. A VIP area is sectioned off in the  
120 building with a sofa type seating area and high-top tables around the restaurant and look more like bar  
121 area seating. He noted the social media still has not changed as well as hours of operation not reflecting  
122 a sports bar. He stated the reservation system, VIP system, and memberships could be used for better and  
123 more premiere seating which is another trait of a nightclub. Councilman Eagan noted the soft opening  
124 ended in a patron being left drunk and assaulted on the side of the road. It was an understanding that a  
125 state-of-the-art video system was supposed to be installed and did not capture the event which unfolded  
126 at the establishment. He stated Mr. Koroma claimed no responsibility in the incident, however, he  
127 violated city ordinances by not notifying the police of the assault. Councilman Parson clarified the initial  
128 beginning request was for a restaurant and bar, but if the liquor license is not approved, he can still open  
129 his establishment as a restaurant without alcohol. Mr. Koroma noted the reason it looks like a nightclub

130 is because it is a modern style of restaurant to allow for easy transitions between different types of events  
131 like corporate parties and special events.

132 On roll call the Council voted: Parson no, Siam no, Harris no, Manganelli no, Eagan no, Caputa  
133 no, Schildroth no, Mulcahy no, and Pagano no. Motion failed.

134 Councilman Siam moved to accept the Request to transfer Special Use Permit no. 8603 from  
135 Shade Partners, LLC to Shade Restaurant & Bar, LLC for the location of a restaurant and bar located at  
136 1752-1756 N. New Florissant Road, seconded by Pagano.

137 Councilman Manganelli moved to suspend the rules to speak with the petitioner, seconded by  
138 Caputa. Motion carried.

139 Lisa West, petitioner, noted the business will be a barbeque restaurant exactly how they requested  
140 it on the previous Special Use Permit. City Attorney Hessel noted the Special use permit would have to  
141 be followed in the transfer and have had discussion of cameras inside and outside the restaurant, no  
142 shading of windows, and staff would potentially have more requests based on each special use transfer.  
143 He mentioned the petitioner may be asked to relocate the smoker and provide cover of the smoker and  
144 smoker enclosure. Ms. West noted the shading on the windows is being removed and her intentions are  
145 the eventually come back and change the restaurant to a brunch location with a full kitchen. She stated  
146 she wants to get in and continue as a barbeque restaurant to start before having a new request for a brunch  
147 restaurant. Ms. West stated she would open at 11am to 10pm Tuesday to Saturday, shorter hours on  
148 Sunday, and closed on Monday. Councilman Siam clarified the smoker would be screened in per the  
149 ordinance. Ms. West noted she has had employees from Shade Restaurant who were interested in  
150 continuing employment, but she noted her high standards may not allow for previous employees to stay  
151 with the business. She also mentioned an application for liquor license will be applied for. Ms. West  
152 stated she worked with a business for 20 years in which she made sure businesses were complying with  
153 State and Local Liquor Laws as well as working with local grocery stores for liquor tastings.

154 The Chair stated that the next item on the agenda was *Bills for First Reading*.

155 Councilman Mulcahy introduced Bill No. 9791 an Ordinance vacating a portion of Brown Street  
156 at St. Joseph (a paper street) was read for the first time.

157 The Council as a whole introduced Bill No. 9792 an Ordinance authorizing an appropriation of  
158 \$17,500 from the Park Improvement Fund to account no. 09-5-09-50040 "Aquatic Center Prop A" to  
159 cover educational materials was read for the first time.

160 Councilman Eagan moved that Bill No. 9792 be read for a second time, seconded by Schildroth.  
161 Motion carried and Bill No. 9792 was read for a second time.



162 Councilman Caputa moved that Bill No. 9792 be read for a third time, seconded by Pagano. On  
163 roll call the Council voted: Parson yes, Siam yes, Harris yes, Manganelli yes, Eagan yes, Caputa yes,  
164 Schildroth yes, Mulcahy yes, and Pagano yes. Having received a unanimous vote of all members present  
165 Bill No. 9785 was read for a third and final time and placed upon its passage. Before the final vote all  
166 interested persons were given an opportunity to be heard.

167 Being no persons who wished to speak, on roll call the Council voted: Parson yes, Siam yes,  
168 Harris yes, Manganelli yes, Eagan yes, Caputa yes, Schildroth yes, Mulcahy yes, and Pagano yes.

169 Whereupon the Chair declared Bill No. 9792 to have passed and become Ordinance No. 8798.

170 The next item on the Agenda was *Council Announcements*.

171 Councilman Manganelli thanked all who came out to the Ward 2 block party and encouraged  
172 everyone to connect with neighbors and have gatherings of their own. He noted the Italian Festival on  
173 October 1<sup>st</sup> is still in the planning stages. Finally, the next Florissant food truck night is Friday, June 17<sup>th</sup>  
174 from 4pm to 8pm at the Knights of Columbus grounds.

175 Councilman Schildroth congratulated John Hessel on his Resolution from the House of  
176 Representatives and the residents near Graham Road and Lowery Estates for their patience during a  
177 power outage in the area.

178 Councilman Caputa reminded residents to lock their firearms in their homes, not their vehicles,  
179 to turn on their porch lights, and join their Neighborhood Watch.

180 Councilman Eagan reminded residents to watch out for their neighbors and pets during the next  
181 few days in the heat.

182 The next item was *Mayor Announcements*.

183 Mayor Lowery noted a plaque dedication would be taking place for Robert and Mark Thielman,  
184 on Wednesday, June 22<sup>nd</sup> on rue St. Francois beginning at 5:30pm. He noted the Mayor's for Meals event  
185 would be taking place from June 20<sup>th</sup> to the 24<sup>th</sup> with six locations for drop off. Mayor Lowery noted the  
186 Hispanic Festival would be taking place on Saturday, June 25<sup>th</sup> from 10am to 10pm and Sunday, June  
187 26<sup>th</sup> from 11pm to 9pm at the Knights of Columbus Grounds. He stated the 4<sup>th</sup> of July celebration would  
188 be taking place at the James J. Eagan Center with a band beginning at 7:15pm and fireworks at 9:15pm.

189 The Council President stated the next regular City Council Meeting will be Monday, June 27,  
190 2022 at 7:00 pm.

191 Councilman Siam moved to adjourn the meeting, seconded by Caputa. Motion carried. The  
192 meeting was adjourned at 8:09 p.m.

193

194

195

196

197

198

199 The following Bills were signed by the Mayor:

200 Bill No. 9782 Ord. No. 8793

201 Bill No. 9783 Ord. No. 8794

202 Bill No. 9784 Ord. No. 8795

203 Bill No. 9788 Ord. No. 8796

204 Bill No. 9789 Ord. No. 8797

205 Bill No. 9792 Ord. No. 8798



---

Karen Goodwin, MPPA/MMC/MRCC  
City Clerk

# **CITY OF FLORISSANT**

## **Public Hearing**



**In accordance with 405.125 of the Florissant Zoning Code a Public Hearing will be held by the City Council of Florissant, MO. in the Council Chambers, 955 rue St. Francois, on Monday, June 27, 2022 at 7:00 p.m. on the following proposition:**

**To authorize a Special Use Permit to Peach Cobbler Factory to allow for the operation of a sit-down, carry-out restaurant for the property located at 12 Paddock Hills Shopping Center in a 'B-3' Extensive Business District. Citizens will have an opportunity to be heard. Anyone with special needs should contact the City Clerk at least 5 days before said public hearing by calling 839-7630 or email [kgoodwin@florissantmo.com](mailto:kgoodwin@florissantmo.com).**

**CITY OF FLORISSANT, Karen Goodwin, MMC City Clerk**

**SPECIAL USE PERMIT APPLICATION  
TO THE CITY OF FLORISSANT  
PLANNING AND ZONING COMMISSION**

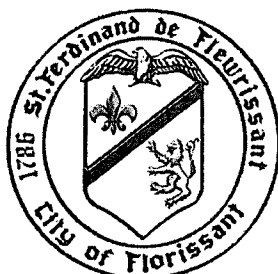

City Of Florissant – Public Works  
314-839-7648

*"Preserve and improve the health, safety, and welfare of our residents, businesses and the general public in the City of Florissant; while at the same time maintaining property values and improving the quality of life in the City of Florissant."*

**PLANNING & ZONING ACTION  
RECOMMENDED APPROVAL  
PLANNING & ZONING  
CHAIRMAN**

Council Ward 9 Zoning B-3'

Initial Date Petitioner Filed \_\_\_\_\_  
Building Commissioner to complete  
ward, zone & date filed

X SIGN. [Signature] DATE: 6-6-2022

SPECIAL PERMIT FOR OPERATION OF BAKERY DESSERT RESTUARANT

Statement of what permit is being sought. (i.e., special permit for operation of a restaurant).

AMEND SPECIAL PERMIT # \_\_\_\_\_ TO ALLOW FOR \_\_\_\_\_  
ordinance # \_\_\_\_\_ Statement of what the amendment is for.

LOCATION 12 PADDOCK HILLS SHOPPING CENTER FLORISSANT, MO 63033  
Address of property.

1) Comes Now NICHOLE BANKS, FOREVER GREEN REALTY SOLUTIONS, LLC (DBA) PEACH COBBLER FACTORY FRANCHISE, LLC  
Enter name of petitioner. If a corporation, state as such. If applicable include DBA (Doing Business As)

and states to the Planning and Zoning Commission that he (she) (they) has (have) the following legal interest in the tract of land located in the City of Florissant, State of Missouri, as described on page 3 of this petition.

Legal interest in the Property) LEASE (SEE ATTACHED)  
State legal interest in the property. (i.e., owner of property, lease).  
Submit copy of deed or lease or letter of authorization from owner to seek a special use.

2) The petitioner(s) further state(s) that the property herein described is presently being used for RETAIL SALE OF COBBLER, CINNAMON ROLLS, BANANA PUDDING, PEACHY TEA, PCF GOLD BREW COFFEE and that the deed restrictions for the property do not prohibit the use which would be authorized by said Permit.

3) The petitioner(s) further states (s) that they (he) (she) are submitting a detailed site plan of the proposed or existing development showing location and use of all structures, off-street parking, and all other information required by the Zoning Ordinance or determined necessary by the Building Commissioner.

4) The petitioner(s) further state(s) that (he) (she) (they) shall comply with all of the requirements of the City of Florissant, including setback lines and off- street parking.

5) The petitioner (s) further (represent (s) and warrants (s) that they (he) (she) has (have) not made any arrangement to pay any commission gratuity or consideration, directly or indirectly to any official, employee or appointee of the City of Florissant, with respect to this application.

6) The petitioner(s) further state (s) that the Special Use Permit is sought for the following purposes, and no other, as listed in detail, all activities sought to be covered by the permit (i.e.; operation of a business, approval of building and/or site plans (preliminary and / or final), plan approval for signage, etc.):

7) The petitioner (s) state (s) the following factors and reason to justify the permit:  
(If more space is needed, separate sheets maybe attached)

NICHOLE BANKS Nichole Banks / NICKY14327@GMAIL.COM (314) 922-3591  
PRINT NAME SIGNATURE email and phone

FOR FOREVER GREEN REALTY SOLUTIONS, LLC  
(company, corporation, partnership)

Print and sign application. If applicant is a corporation or partnership signature must be a CORPORATE OFFICER or a PARTNER. NOTE: Corporate officer is an individual named in corporate papers.

8) I (we) hereby certify that, as applicant (circle one of the following):

- 1. I (we) have a legal interest in the herein above described property.
- 2. I am (we are) the duly appointed agent(s) of the petitioner (s), and that all information given here is true and a statement of fact.

Permission granted by the Petitioner assigning an agent (i.e. Architect) to present this petition in their behalf, to the Commission and/or Council. The petitioner must sign below, and provide contact information:

PRESENTOR SIGNATURE \_\_\_\_\_

ADDRESS \_\_\_\_\_  
STREET CITY STATE ZIP CODE

TELEPHONE / EMAIL \_\_\_\_\_  
BUSINESS

I (we) the petitioner (s) do hereby appoint \_\_\_\_\_ as  
Print name of agent.  
my (our) duly authorized agent to represent me (us) in regard to this petition.

\_\_\_\_\_  
Signature of Petitioner authorizing an agent

**NOTE:** When the petitioner and/or his duly authorized agent appears before the Planning and Zoning Commission and to make a presentation, the same individuals must also appear before the City Council at the Public Hearing to make the presentation and no one else will be permitted to make the presentation to the City Council without authorized approval.

IF DESCRIPTIONS, PLATS OR SURVEYS ARE INACCURATE, OR IF THE PETITION APPLICATION IS NOT CORRECT OR COMPLETE, IT WILL BE RETURNED FOR ADDITIONS OR CORRECTIONS.

## REQUIRED INFORMATION

Please mark an "X" in the appropriate type of operation, then fill in applicable section (a), (b) or (c).  
Corporations are to submit copy of Missouri corporate papers with registration papers.

1) Type of Operation:  
Individual  Partnership \_\_\_\_\_ Corporation \_\_\_\_\_

(a) If an individual:

- (1) Name and Address NICHOLE BANKS 4133 JOYFUL COURT FLORISSANT, MO 63034
- (2) Telephone Number (314) 922-3571
- (3) Business Address 12 PADDOCK HILLS CENTER FLORISSANT, MO 63033
- (4) Date started in business 02/10/2022 PCF FRANCHISE, LLC AGREEMENT
- (5) Name in which business is operated if different from (1) FOREVER GREEN REALTY SOLUTIONS, LLC 02/26/2018
- (6) If operating under a fictitious name, provide the name and date registered with the State of Missouri, and a copy of the registration.

(b) If a partnership:

- (1) Names & addresses of all partners \_\_\_\_\_
- (2) Telephone numbers \_\_\_\_\_
- (3) Business address \_\_\_\_\_
- (4) Name under which business is operated \_\_\_\_\_
- (5) If operating under fictitious name, provide date the name was registered with the State of Missouri, and a copy of the registration.

(c) If a corporation:

- (1) Names & addresses of all partners \_\_\_\_\_
- (2) Telephone numbers \_\_\_\_\_
- (3) Business address \_\_\_\_\_
- (4) State of Incorporation & a photocopy of incorporation papers \_\_\_\_\_
- (5) Date of Incorporation \_\_\_\_\_
- (6) Missouri Corporate Number \_\_\_\_\_
- (7) If operating under fictitious name, provide the name and date registered with the State of Missouri, and a copy of registration. \_\_\_\_\_
- (8) Name in which business is operated \_\_\_\_\_
- (9) Copy of latest Missouri Anti-Trust. (annual registration of corporate officers) If the property location is in a strip center, give dimensions of your space under square footage and do not give landscaping Information.

Please fill in applicable information requested. If the property is located in a shopping center, provide the dimensions of the tenant space under square footage and landscaping information may not be required.

Name FOREVER GREEN REALTY SOLUTIONS, LLC DBA THE PEACH COBBLER FACTORY FRANCHISE, LLC  
Address 12 PADDOCK HILLS CENTER FLORISSANT, MO 63033  
Property Owner PADDOCK EQUITY INVESTORS, LLC  
Location of property 2200 N.LINDBERG BLVD. PART OF PADDOCK VILLAGE SHOPPING CENTER  
Dimensions of property +/-19'.0", +/-75'-8" SEE PREMISES (EXHIBIT A)  
Property is presently zoned \_\_\_\_\_ Requests Rezoning To \_\_\_\_\_  
Proposed Use of Property RETAIL SALE OF COBBLER, CINNAMON ROLLS, BANANA PUDDING, PEACHY TEA, PCF COLD BREW COFFEE & MILK  
Type of Sign SEE LEASE (EXHIBIT D) CODE MAXIMUM Height \_\_\_\_\_  
Type of Construction SEE PCF WORK LETTER AND FLOOR PLAN Number Of Stories \_\_\_\_\_  
Square Footage of Building 1618 SF SEE PREMISES (EXHIBIT A) Number of Curb Cuts \_\_\_\_\_  
Number of Parking Spaces SEE SITE PLAN (EXHIBIT B) Sidewalk Length \_\_\_\_\_  
Landscaping: No. of Trees \_\_\_\_\_ Diameter \_\_\_\_\_  
No. of Shrubs \_\_\_\_\_ Size \_\_\_\_\_  
Fence: Type \_\_\_\_\_ Length \_\_\_\_\_ Height \_\_\_\_\_

**PLEASE SUBMIT THE FOLLOWING INFORMATION ON PLANS OR DRAWINGS:**

1. Zoning of adjoining properties.
2. Show location of property in relation to major streets and all adjoining properties.
3. Show measurement of tract and overall area of tract.
4. Proposed parking layout and count, parking lighting.
5. Landscaping and trash screening.
5. Location, sizes and elevations of signage.

**PROVIDE LEGAL DESCRIPTION OF PROPERTY PERTAINING TO THIS PETITION**

(Close legal description with acreage to the nearest tenth of an acre).

Provide a legal description of the property. If part of a shopping center, list address and show part of what shopping center (i.e.: 351 N. Highway 67 part of Florissant Meadows Shopping Center). If property is a single lot, list full written legal description with metes and bounds bearings and dimensions.

**PROVIDE LOCATION MAP SHOWING AREA INVOLVING THIS PETITION**  
Provide a drawing of a location map showing the nearest major intersection.

**OFFICE USE ONLY**

Date Application reviewed \_\_\_\_\_

6/1/22

STAFF REMARKS: \_\_\_\_\_  
\_\_\_\_\_  
\_\_\_\_\_

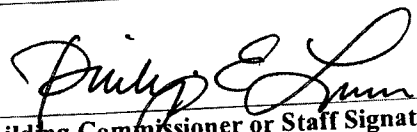
  
\_\_\_\_\_  
Building Commissioner or Staff Signature





39 The existing building was built in 1964 per County record, which lists the Shopping  
40 Center that currently houses other Uses.

41  
42 The rent roll document provided 133,330 s.f. of building lease space including the USPS  
43 facility of 54,482 s.f., but this is located on a separate parcel 2200 N Hwy 67.

44  
45 **III. SURROUNDING PROPERTIES:**

46 The property to the East is the Post Office at 2190 and 2200 N Highway 67, zoned  
47 similarly in the 'B-3' Extensive Business District. The properties to the North are 2100  
48 US Bank, 2180 and 2182 McAlister's and Rally's in a 'B-5' District.

49  
50 **IV. STAFF ANALYSIS:**

51 Plan received from the applicant include plan consisting of removal of back of house  
52 rooms leaving an existing restroom and employee area. The occupant load must remain  
53 low for this to be considered a 'B' Business Use Group, without a second restroom.  
54 Otherwise, it could be required to be an A-2 Assembly Use.

55  
56 **Comments on Drawings:**

57  
58 Plan shows very limited total seating in the Guest Area, 12 seats. Therefore parking  
59 generated as calculated by the parking code for a restaurant is one space for every 3 seats  
60 and 2 spaces for every 3 employees on the max. shift, or about 5.

61  
62 Total parking required 5, total provided for the entire shopping center complex can be  
63 calculated as a "*Commercial Service Retail Center minimum parking table is applicable*  
64 *when there is a mixed-use development that is owned and managed as a single unit.*"  
65 parking area is in abundance, perhaps as many as 316 as a total parking counted by aerial  
66 photo, however some of the parking along N Waterford has faded striping of about 60  
67 spaces along N Waterford.

68  
69 A Commercial Service Retail Center is required to have 4/1000 s.f. per the current  
70 parking code, or  $60.7 \times 4 = 242$  Total spaces required, so the Shopping Center can  
71 comply with parking counts.

72  
73 Petitioner describes bakery and desserts with limited seating.

74  
75 **III. STAFF RECOMENDATIONS:**

76  
77 **Suggested Motion:**

78 I move for Recommended Approval of a Special Use to allow for a sit-down carryout  
79 bakery/restaurant establishment in a 'B-3' Extensive Business District as shown on plans  
80 attached, subject to the conditions set forth below with these conditions being part of the  
81 record:

82  
83 (End of report and suggested motion)

**EXHIBIT B**  
**SITE PLAN**

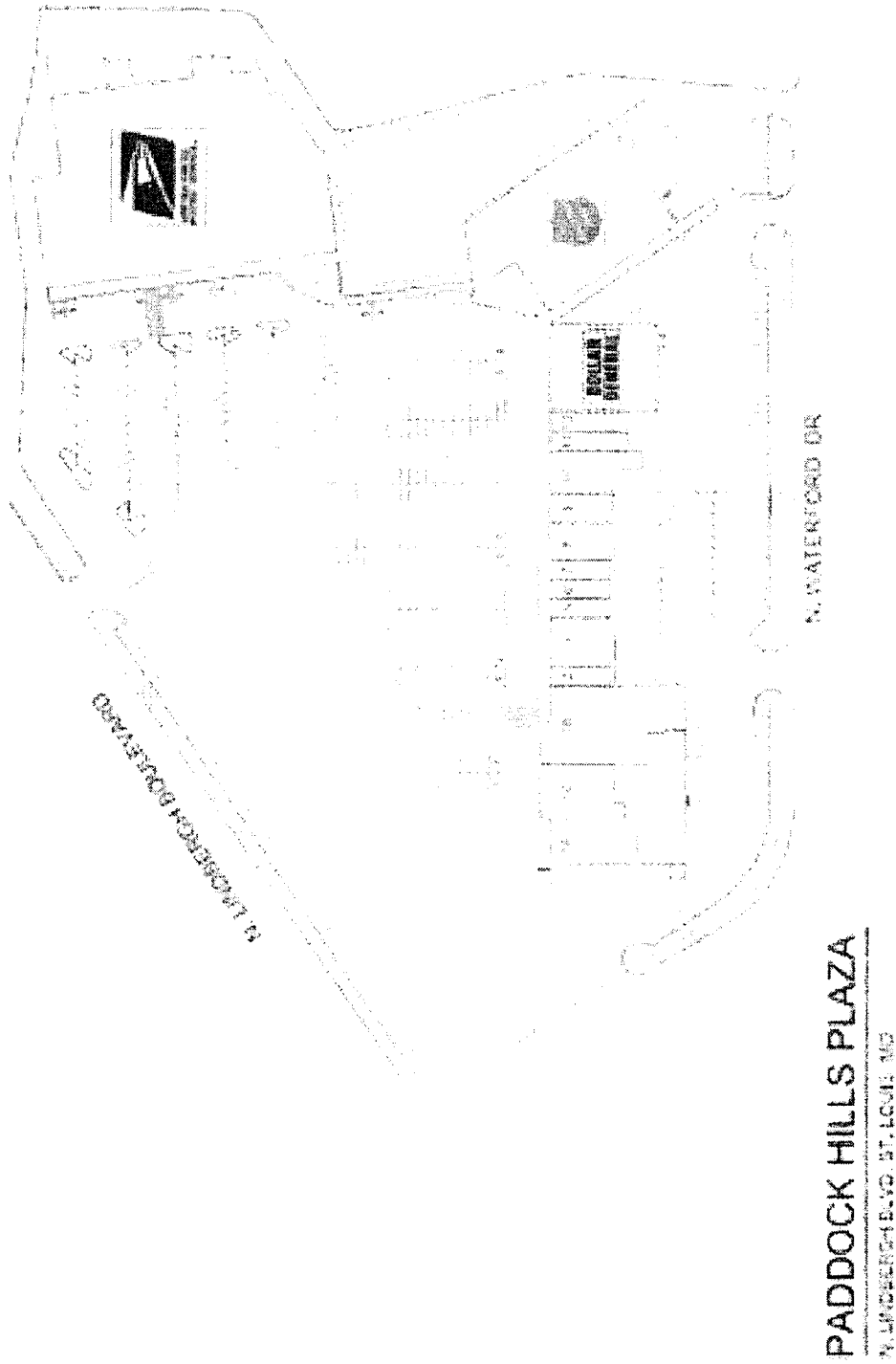

*WS*  
*mm*  
INITIALS

INITIALS



**PART OF BLOCKS 43 & 44 OF  
ST. FERDINAND COMMONS  
CITY OF FLORESSANT,  
ST. LOUIS COUNTY, MISSOURI.**



Plan & Zoning  
Commission  
Date: SEP 18 1993

**Rent Roll**

Property: 224 From Date: 05/16/2022 By Property

Property	Unit(s)	USE	Area
<b>224 - Paddock Hills Shopping Plaza, Florissant</b>			
<b>Current Leases</b>			
224	1A, 1B, 1C	Retail sale of new and second hand goods	16,543.00
224	1D	Warehouse, distribution, pick-up and delivery of goods	10,504.00
224	2	Nail Salon	1,162.00
224	20	USPS - mail, retail sale stamps and misc items	54,482.00
224	3-4	Laundrymat	3,040.00
224	5	Thai Restaurant	1,214.00
224	6	Retail Net	1,204.00
224	7	Eyelash extensions	1,214.00
224	8	retail sale of gardening supplies	2,458.00
224	9	VACANT	2,027.00
224	10	Sports Bar	3,108.00
224	11	Personal Training	1,752.00
224	12	Retail sale of cobbler, cinnamon rolls and etc	1,618.00
224	15	Retail	10,416.00
224	17-19	Retail Sale of Second Hand goods	22,588.00
<b>Total Current</b>			<b>133,330.00</b>

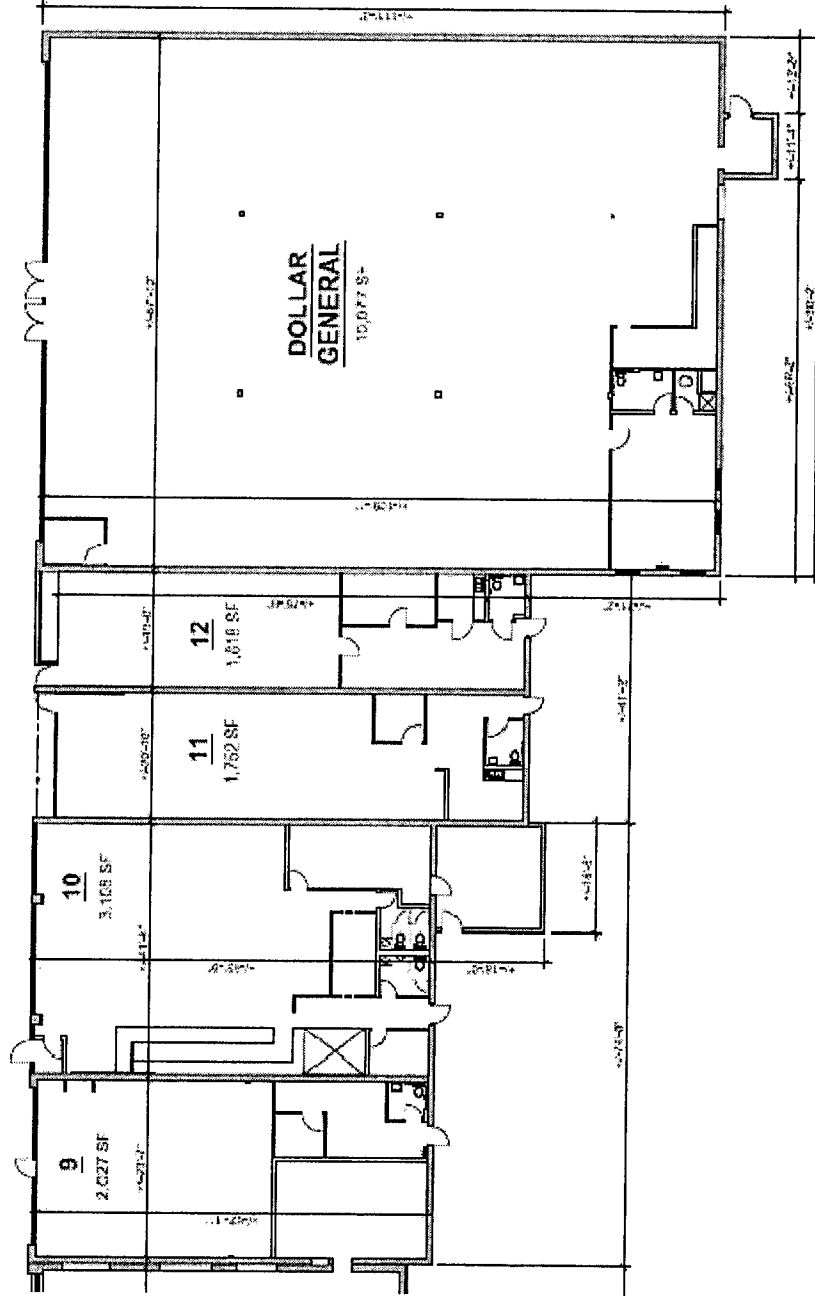

**RANGWALA ARCHITECTS**  
ARCHITECTS & PLANNERS  
PROFESSIONALS

**FLOOR PLAN - LIVING CONNECTIVITY PHASE 2**

**PADDOCK HILLS PLAZA**  
N LINCOLN BLVD. ST. LOUIS, MO  
01-18-E

EXHIBIT A  
PREMISES

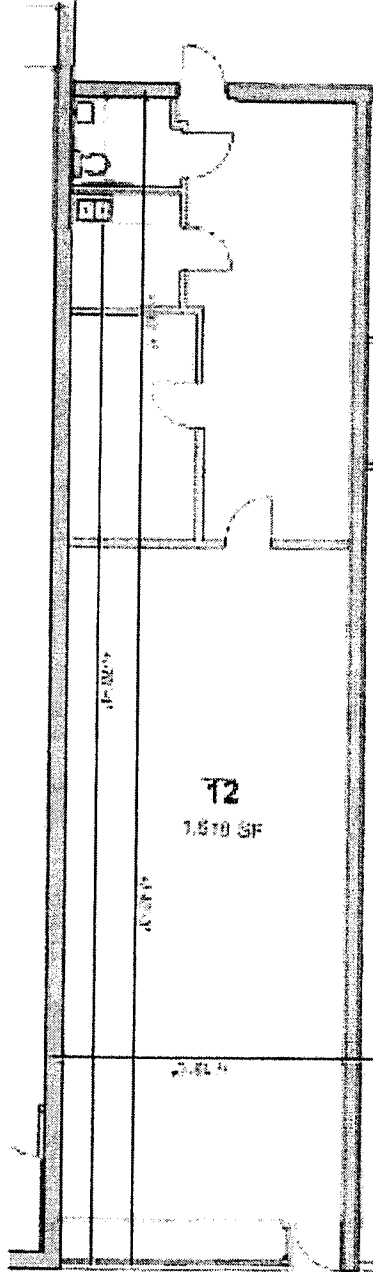

*WBS* *AN*  
INITIALS

\_\_\_\_\_  
INITIALS

PEACH COBBLER FACTORY  
 OWNER: NICHOLE BANKS  
 12 PADDOCK HILLS PLAZA ST. LOUIS, MO.

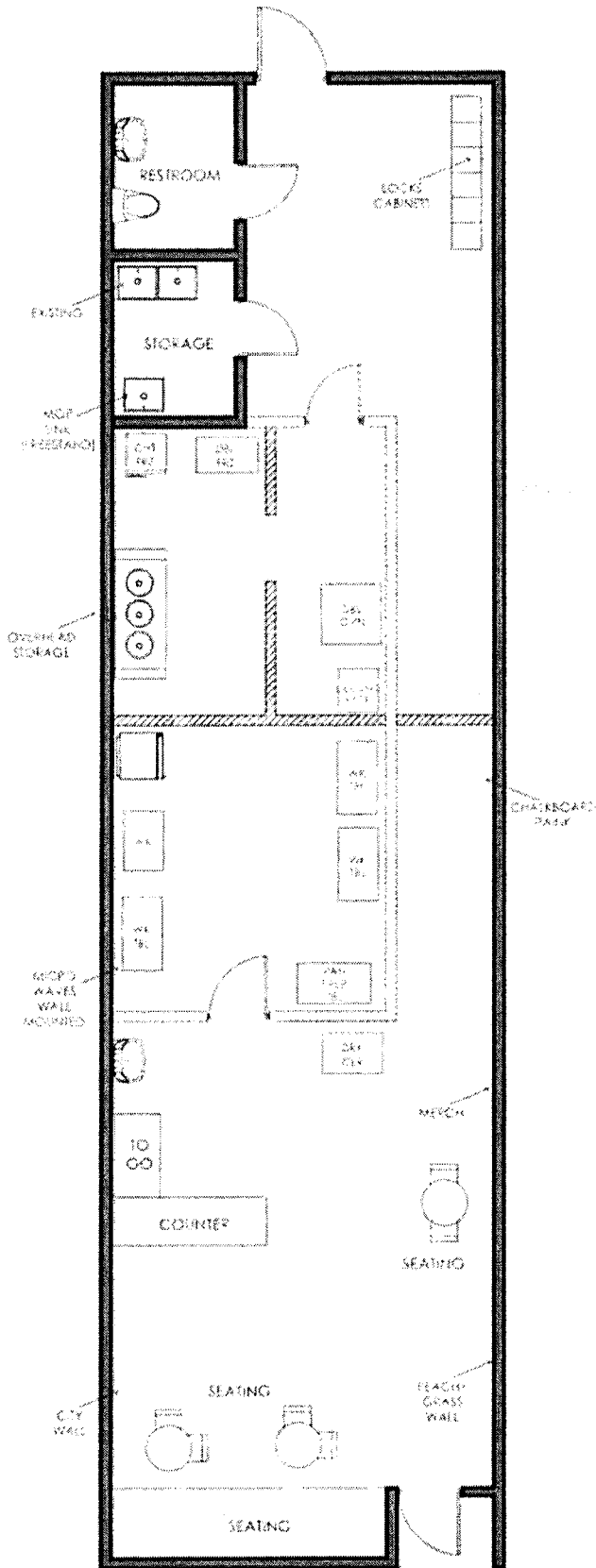
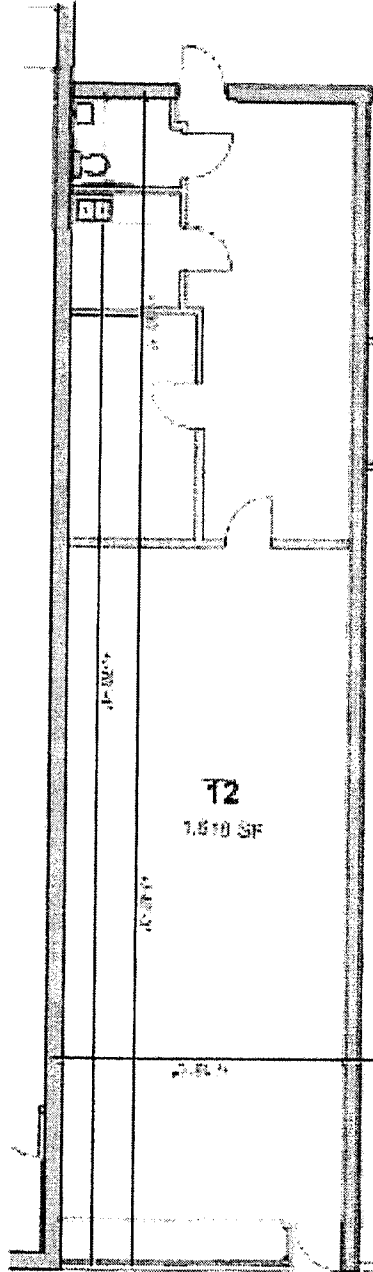



EXHIBIT A  
PREMISES



*WBS MN*  
INITIALS

\_\_\_\_\_  
INITIALS

PEACH COBBLER FACTORY  
 OWNER: NICHOLE BANKS  
 12 PADDOCK HILLS PLAZA ST. LOUIS, MO.

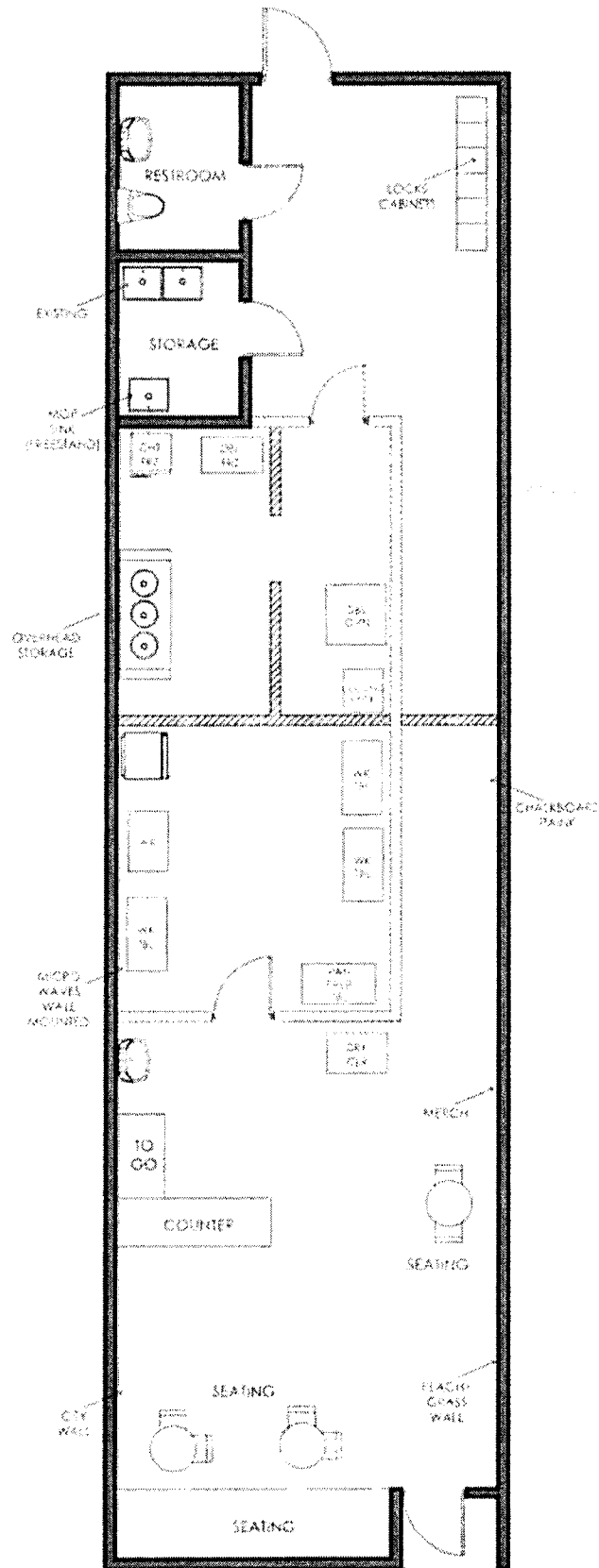

PADDOCK HILLS PLAZA  
N LINCOLN BLVD, ST. LOUIS, MO

01-18-76

LOGS PLAN - LMS INC CONSULTING PART 1

RANGWAL ARCHITECTS  
ARCHITECTS, P.C.  
PROJECT NUMBER: 01-18-76

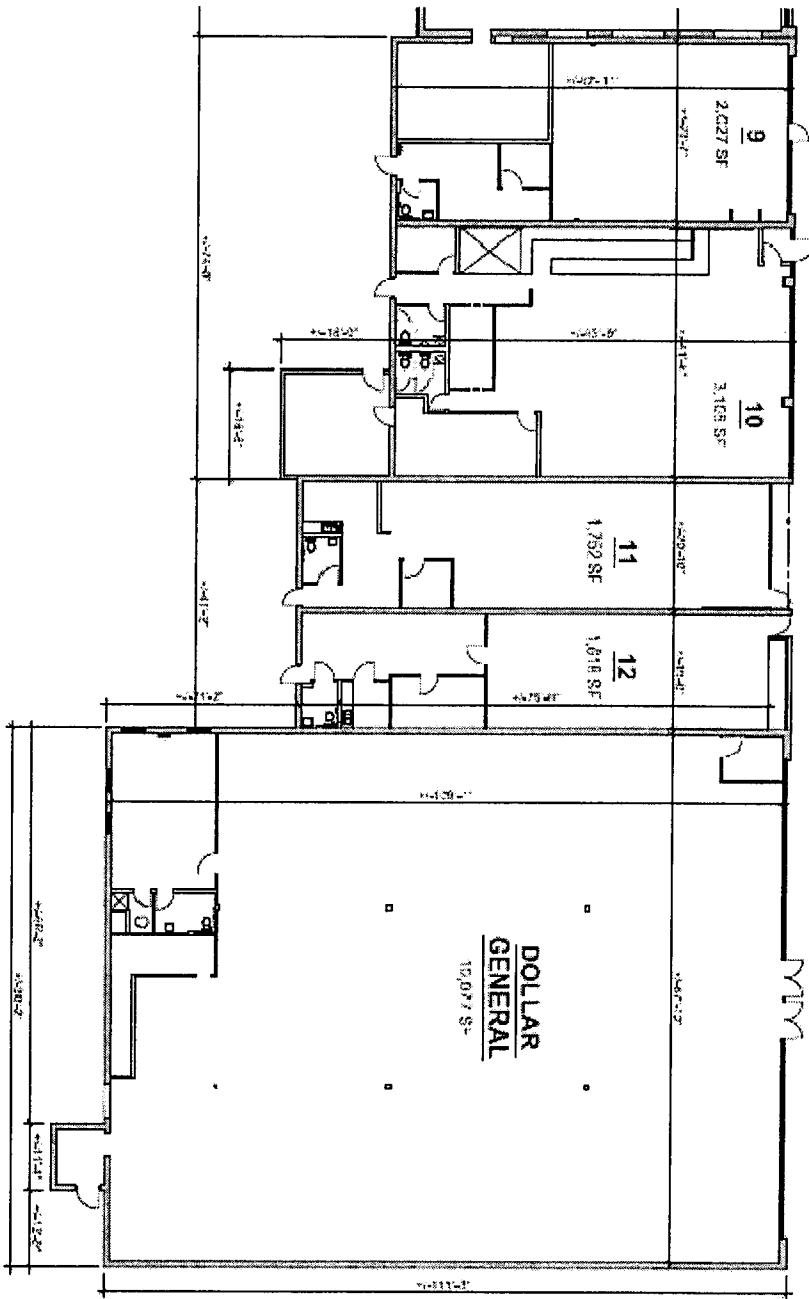

PART OF BLOCKS 43 & 44 OF  
**ST. FERDINAND COMMONS**  
 CITY OF FLOISSANT,  
 ST. LOUIS COUNTY, MISSOURI.

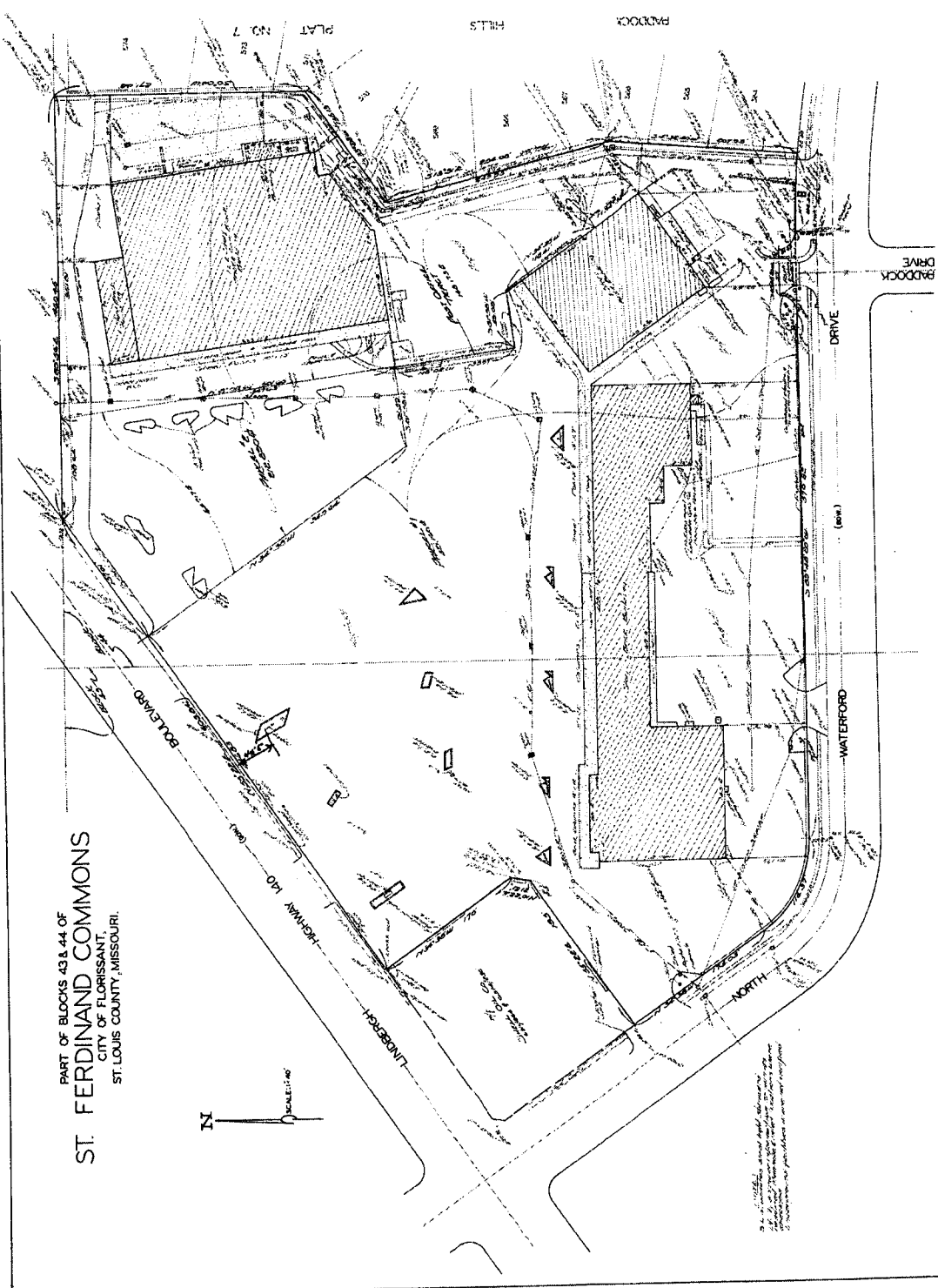
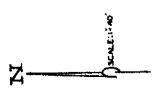

Surveyed and Platted by  
 [Name]  
 Surveyor  
 State of Missouri



These plans were prepared by the undersigned in accordance with the provisions of the laws of the State of Missouri, and the same are hereby certified to be correct and true to the original survey and plat on file in the office of the Surveyor General of the State of Missouri.

Plan & Zoning  
 Commission  
 Date 3/19/83

# **CITY OF FLORISSANT**

## **Public Hearing**



**In accordance with 405.135 of the Florissant Zoning Code a Public Hearing will be held by the City Council of Florissant, MO. in the Council Chambers, 955 rue St. Francois, on Monday, June 27, 2022 at 7:00 p.m. on the following proposition:**

**To amend 'B-5' Ord. No. 5854 (as amended) to allow for changes in the drive-thru located at 2375 N. Hwy 67 (Panera, LLC). Citizens will have an opportunity to be heard. Anyone with special needs should contact the City Clerk at least 5 days before said public hearing by calling 839-7630 or email [kgoodwin@florissantmo.com](mailto:kgoodwin@florissantmo.com).**

**CITY OF FLORISSANT, Karen Goodwin, MMC City Clerk**

**APPLICATION TO THE CITY OF FLORISSANT PLANNING AND ZONING  
COMMISSION TO AMEND THE PROVISIONS OF AN EXISTING B-5  
PLANNED COMMERCIAL DISTRICT ORDINANCE**

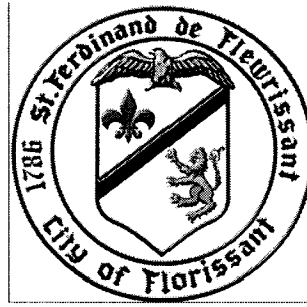

**PLANNING & ZONING ACTION:**

Address of Property:

2375 N Highway 67 (Lindbergh) Street

**RECOMMENDED APPROVAL  
PLANNING & ZONING  
CHAIRMAN**

Council Ward 9 Zoning B-5

Initial Date Petitioner Filed \_\_\_\_\_  
**Building Commissioner to complete  
ward, zone & date filed**

X SIGN [Signature] DATE: 6-6-2022

PETITION TO AMEND B-5 ORDINANCE # 7322

Enter ordinance number or number requesting to amend.

1) Comes Now Panera, LLC

(Individual's name, corporation, partnership, etc.)

Enter name of petitioner. If a corporation, state as such. If applicable include DBA (Doing Business As).

and states to the Planning and Zoning Commission that he (she) (they) has (have) the following legal interest in the tract of land located in the City of Florissant, State of Missouri, described on page 3 of this petition.

Legal interest in the Property Lessee

State legal interest in the property. (i.e., owner of property, lease); also submit copy of deed or lease or letter of authorization from owner to seek a special use.

- A. The petitioner (s) hereby states that he (she) (they) is (are) submitting a description of the property for which the Permit is petitioned by giving bearings & distances (metes and bounds). Not required if description is identical to "B".
- B. The petitioner (s) hereby states that he (she) (they) is (are) submitting a survey or plat of the property drawn to a scale of 100 feet or less to the inch, referenced to a point easily located on the ground as street intersection, centerline of creek having a generally known name, etc., showing dimensions, bearings and distances of the property, north arrow and scale.
- C. Acreage to nearest tenth of an acre of the property for which rezoning is petitioned 1.18

2. The petitioner(s) hereby further state(s) that the property herein described in this petition is presently zoned in a B-5 District and is presently being used for restaurant with drive thru services

**State current use of property, (or, state: vacant).**

3. The petitioner(s) hereby state(s) the following reasons to justify the amendment to the existing B-5 ordinance:  
Revisions to the existing drive thru layout to allow two (2) lanes and updates to the drive thru window

**List reason for the amendment request.**

4. The petitioner(s) further states(s) that they (he) (she) can comply with all of the requirements of the City of Florissant, including setback lines and off-street parking.
5. The petitioner(s) further state(s) that they (he) (she) further represent(s) and warrants that they (he) (she) has (have) not made any arrangement to pay any commission, gratuity or consideration, directly or indirectly, to any official employee or appointee of the City of Florissant, with respect to this application.

PRINT PETITIONER'S NAME Civil & Environmental Consultants, Inc / Patrick T. Bennett, PE

**Print Name**

PETITIONER(S) SIGNATURE (S) \_\_\_\_\_

FOR Panera, LLC

(company, corporation, partnership)

**Print and sign application. If applicant is a corporation or partnership signature must be a CORPORATE OFFICER or PARTNER. NOTE: Corporate officer is an individual named in corporate papers.**

6. I (we) hereby certify that (indicate one of the following):
- ( ) I (we) have a legal interest in the herein above described property.
  - ( ) I am (we are) the duly appointed agent(s) of the petitioner (s), and that all information given here is true and a statement of fact.

**Petitioner may assign an agent to present petition to the Commission and Council. The agent must sign the petition in this section, and provide address and telephone number**

SIGNATURE \_\_\_\_\_

ADDRESS \_\_\_\_\_  
**STREET CITY STATE ZIP CODE**

TELEPHONE NUMBER \_\_\_\_\_  
**BUSINESS**

I (we) the petitioner (s) do hereby appoint \_\_\_\_\_ as  
**Print name of agent.**  
my (our) duly authorized agent to represent me (us) in regard to this petition.

\_\_\_\_\_  
**Signature of Petitioner(s) or Authorized Agent**

**NOTE:** Be advised when the petitioner and/or his duly authorized agent appears before the Planning and Zoning Commission and make the presentation, the same individuals must also appear before the City Council for that presentation. Also if the descriptions of plats or surveys are incorrect, or if the petition form is not correctly and completely filled out it will be returned for corrections and may have to be re-submitted.

**Please check the box for the appropriate type of operation then fill in applicabe section (a), (b) or (c). Corporations are to submit copy of Missouri corporate papers with registration papers.**

1) Type of Operation: Individual:  Partnership:  Corporation:

(a) If an individual:

- (1) Name and Address \_\_\_\_\_
- (2) Telephone Number \_\_\_\_\_
- (3) Business Address \_\_\_\_\_
- (4) Date started in business \_\_\_\_\_
- (5) Name in which business is operated if different from (1) \_\_\_\_\_
- (6) If operating under a fictitious name, provide the name and date registered with the State of Missouri, and a copy of the registration.

(b) If a partnership:

- (1) Names & addresses of all partners \_\_\_\_\_
- (2) Telephone numbers \_\_\_\_\_
- (3) Business address \_\_\_\_\_
- (4) Name under which business is operated \_\_\_\_\_
- (5) If operating under fictitious name, provide date the name was registered with the State of Missouri, and a copy of the registration.

(c) If a corporation:

- (1) Names & addresses of all partners \_\_\_\_\_
- (2) Telephone numbers \_\_\_\_\_
- (3) Business address \_\_\_\_\_
- (4) State of Incorporation & a photocopy of incorporation papers \_\_\_\_\_
- (5) Date of Incorporation \_\_\_\_\_
- (6) Missouri Corporate Number \_\_\_\_\_
- (7) If operating under fictitious name, provide the name and date registered with the State of Missouri, and a copy of registration. \_\_\_\_\_
- (8) Name in which business is operated \_\_\_\_\_
- (9) If the property location is in a strip center, give dimensions of your space under square footage and do not give landscaping information.



Please fill in applicable information requested.

Name Panera, LLC

Address 3630 Geyer Road, Suite 100, St. Louis, MO 63127

Property Owner The MJJCJ Family Trust etal

Location of property 2375 N Highway 67 Street

Dimensions of property roughly 297' x 177'

Property is presently zoned B-5 per ordinance # 7322

Current & Proposed Use of Property Restaurant with drive thru

Type of Sign N/A Height \_\_\_\_\_

Type of Construction N/A Number Of Stories 1

Square Footage of Building 4,736 Number of Curb Cuts \_\_\_\_\_

Number of Parking Spaces 66 Sidewalk Length N/A

Landscaping: No. of Trees \_\_\_\_\_ Diameter \_\_\_\_\_

No. of Shrubs \_\_\_\_\_ Size \_\_\_\_\_

Fence: Type N/A Length N/A Height N/A

**PLEASE SUBMIT NINE (9) FOLDED COPIES OF THE FOLLOWING:**

1. Plan or drawing showing zoning of adjoining properties.
2. Plan or drawing showing location of property in relation to major streets and all adjoining properties.
3. Drawing showing measurement of tract and overall area of tract.
4. Plan or drawing showing proposed parking layout, landscaping, parking lighting, signage and trash enclosure.

**PROVIDE LEGAL DESCRIPTION OF PROPERTY PERTAINING TO THIS  
PETITION**

(Close legal description with acreage to the nearest tenth of an acre).

**Provide a legal description of the property. If part of a shopping center list address and state part of what shopping center (i.e.: 351 N. Highway 67 part of Florissant Meadows Shopping Center). If property is a single lot, list full written legal description with bearings and distances.**

PIDGEON PARK FLORISSANT, OUTLOT PARCEL 1

**PROVIDE LOCATION MAP SHOWING AREA INVOLVING THIS PETITION**

**Provide a drawing of a location map showing the nearest major intersection or include on plans.**

1

**MEMORANDUM**

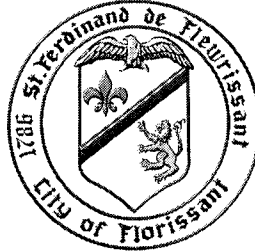

2

**CITY OF FLORISSANT**

3

4

5

6

7

8

9

10

11

12

13

14

15

16

17

18

19

20

21

22

23

24

25

26

27

28

29

30

31

32

33

34

35

36

37

38

39

40

*"Preserve and improve the health, safety, and welfare of our residents, businesses and the general public in the City of Florissant; while at the same time maintaining property values and improving the quality of life in the City of Florissant."*

To: Planning and Zoning Commissioners Date: June 1, 2022

From: Philip E. Lum, AIA-Building Commissioner copy: Todd Hughes, P.E.  
Director of Public Works  
Deputy City Clerk  
Applicant  
File

Subject: Request Recommended Approval to amend the provisions of a 'B-5' Zoning District, located at **2375 N Highway 67 (Panera, LLC)** Ord. No. 5854 (as amended by Ords. No. 7322 and 7962) to allow for changes in the drive-thru.

**STAFF REPORT**  
**CASE NUMBER PZ-060622-2**

**I. PROJECT DESCRIPTION:**

This is a request for Recommended Approval to amend the provisions of a 'B-5' Zoning District, located at **2375 N Highway 67 (Panera, LLC)** Ord. No. 5854 (as amended by Ords. No. 7322 and 7962) to allow for changes in the drive-thru.

**II. SITE CONDITIONS:**

This property has been used for a restaurant since 1997. The current restaurant is 4962 square feet and there are 72 parking spaces. There are no identified violations of the current B-5 requirements.

**III. SURROUNDING PROPERTIES:**

This property is completely surrounded by commercial B-5 developments. The adjacent Lot is a Target Store to the West of this proposed development in a B-5 Zoning District. The property to the North and to the East is are in a B-5 Zoning District.

**IV. STAFF ANALYSIS:**

- The application is accompanied by professionally completed submissions including SUV-1 dated 11/19/2020, SP01 dated 5/5/2022, SP02 dated 5/5/2022, LA01 dated 5/9/2022 and A101 dated 4/22/2022.

41  
42  
43  
44  
45  
46  
47  
48  
49  
50  
51  
52  
53  
54  
55  
56  
57  
58  
59  
60  
61  
62  
63  
64  
65  
66  
67  
68  
69  
70  
71  
72  
73  
74  
75  
76  
77  
78  
79  
80  
81  
82  
83  
84  
85  
86

- 2. Comments on plan submissions received:
  - SUV-1: Partial Boundary, Topographic and Improvements- drawing appears to show all existing utilities and topography.
  - SP01: Amended Site Plan shows 2 drive through lanes instead of the one that currently exists. The outer lane is for Rapid Pickup Service instead of an order lane. Both lanes are divided by a raised concrete island. The parking opposite the pickup window has been changed to angle parking. The drive through window is replaced with a full height door.
  - SP02: Shows pavement replacement areas, pavement markings prior to lane merger. There is no detailed description of the pavement markings, but submissions in the past have been made that indicate a “Please Stop Here” striping in Olive Green color.
  - LA01: Landscaping near to the building appears to be replaced. Outer island is to be protected and mulched.
  - A101: Shows some equipment replacement on the plan, but elevation 3/A200 was not submitted, so there is no East elevation.

**VI. STAFF ANALYSIS/RECOMMENDATIONS:**

This development was originally approved as a Boston Market with a drive up window however the drive up window was never installed. The ordinance was amended to use the drive up portion of the building with added signage. A later amendment allowed for the change in the East signage.

The petitioner should be prepared to present staff foot traffic and vehicle control measures description and describe site safety.

**Suggested Motion**

I move for Recommended Approval to amend the provisions of a ‘B-5’ Zoning District, located at **2375 N Highway 67 (Panera, LLC)** Ord. No. 5854 (as amended by Ords. No. 7322 and 7962) to allow for changes in the drive-thru as follows:

1. Ordinance No. 5854 granted to Panera, LLC for a ‘B-5’ Planned Commercial District Development shall be amended to allow for the addition of a drive thru lane with additional signage in accordance with attached drawings SP01 dated 5/5/2022, SP02 dated 5/5/2022, LA01 dated 5/9/2022 and A101 dated 4/22/2022 by Civil & Environmental Consultants, Inc.
2. Ordinance No. 5854 shall otherwise remain in full force and effect.
3. *Add traffic bollards to protect outdoor seating, s. side.*  
(end report and suggested motion)



# PANERA #617

## AMENDED SITE DEVELOPMENT PLAN

NORTH LINE OF OUTLOT PARCEL 1 OF AMENDED PIDGEON PARK  
 FLORISSANT - PLAT 2, PB 345, PG 495, ST. LOUIS COUNTY, MISSOURI

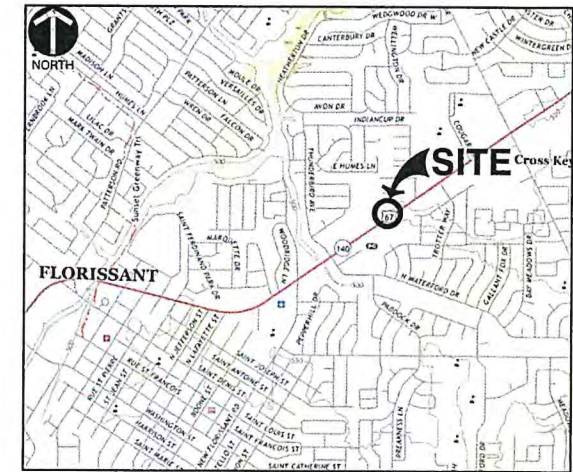
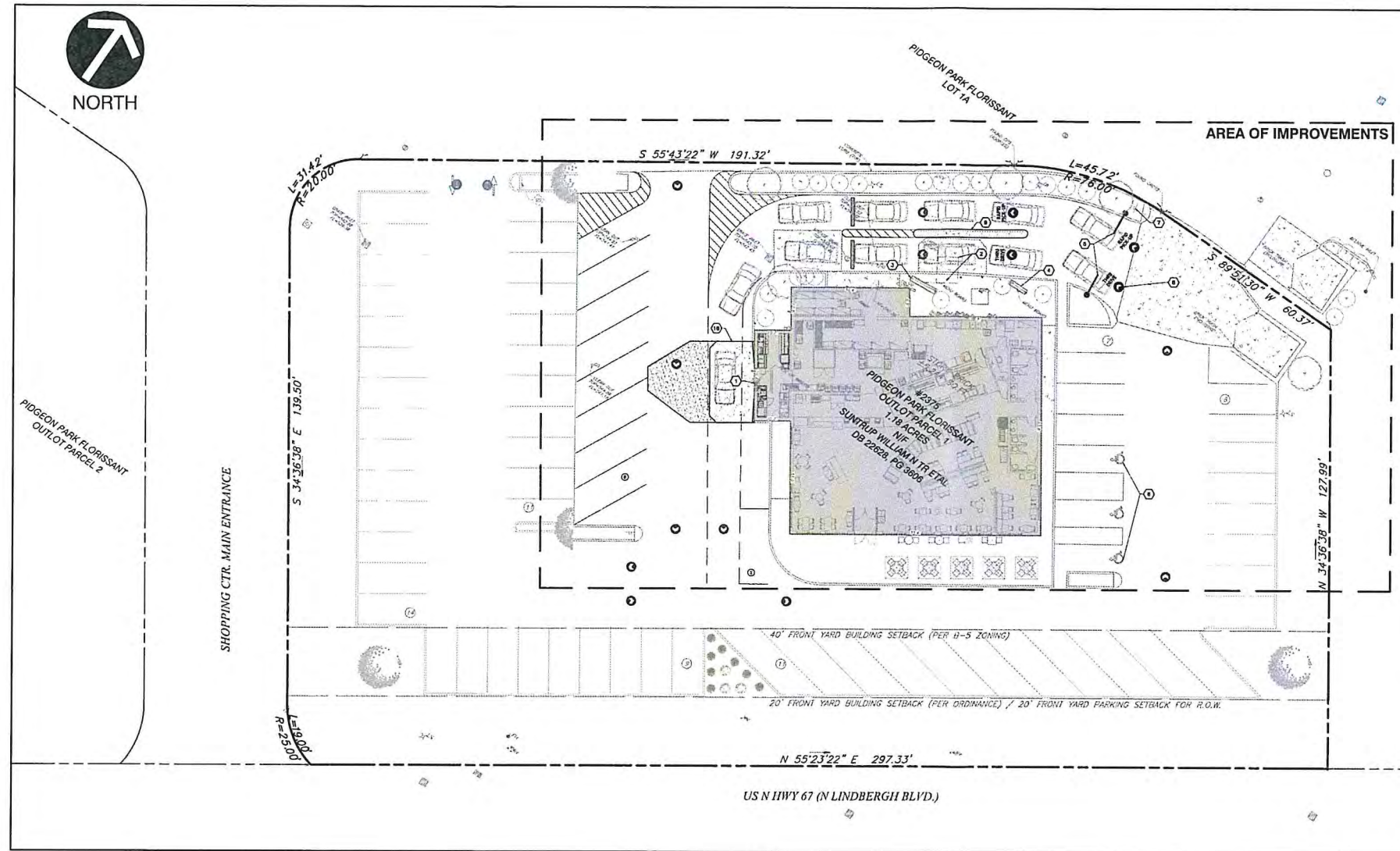

**U.S.G.S. MAP**  
 U.S.G.S. 7.5 MIN. TOPOGRAPHIC MAP,  
 FLORISSANT QUADRANGLE, MO, DATED: 2021  
 1"=2,000'  
 SCALE IN FEET  
 0 1000' 2000'

**DEVELOPMENT NOTES:**

1. ADDRESS: 2375 NORTH HIGHWAY 67  
FLORISSANT, MO 63033
2. PACEL ID: 07J340324
3. AREA OF TRACT: 1.18 ACRES
4. ZONING: B-5 PLANNED COMMERCIAL, ORD.#5854 (ORD.#7962 MARCH 25, 2013; ORD.#7322 JULY 24, 2006)
5. WARD: 9
6. ADJACENT ZONING: NORTH- B-5  
WEST- B-5  
EAST- B-5
7. AREA REGULATIONS:  
MINIMUM LOT AREA, NONE.  
MAXIMUM STORY, THREE (3) STORIES.  
MAXIMUM HEIGHT, FORTY-FIVE (45) FEET.  
MINIMUM DEPTH (REAR YARD), NONE.  
MINIMUM WIDTH (SIDE YARD), NONE.  
MINIMUM PARKING SETBACK R.O.W. TWENTY (20) FEET.
8. PARKING:  
REQUIRED- 1 SPACE FOR EVERY 2 SEATS PLUS 2 SPACES FOR EVERY 3 EMPLOYEES ON THE MAXIMUM SHIFT AND 5 STACKING PLUS 1 AT ORDER STATION  
= 70 SPACES [65.5 (105 INTERIOR + 26 EXTERIOR SEATS = 131 TOTAL) + 4 (12 MAX SHIFT)]  
PROVIDED-  
= 70 SPACES (INCL. 3 ADA SPACES W/ 1 BEING VAN ACCESSIBLE)  
= 7 DRIVE THRU STACKING (6 + 1)
9. PROPERTY LIES IN ZONE "X" DETERMINED TO BE OUTSIDE THE 500-YEAR FLOOD PLAN. COMMUNITY-PANEL NUMBER 29189C0066K EFFECTIVE DATE, FEBRUARY 4, 2015.

**OVERALL SITE**  
 SCALE IN FEET  
 0 20 40

**PROJECT TEAM**  
**PANERA BREAD**  
 3630 S. GEYER ROAD, SUITE 100  
 ST. LOUIS, MO 63127  
 PH: (618) 719-8882  
 CONTACT: LEVI OTWELL  
 EMAIL: levi.otwell@panerabread.com

**CIVIL ENGINEER**  
 CIVIL & ENVIRONMENTAL CONSULTANTS, INC.  
 3000 LITTLE HILLS EXPRESSWAY, SUITE 102  
 ST. CHARLES, MO 63301  
 PH: (314) 656-4566  
 PATRICK BENNETT, P.E.  
 EMAIL: pbennett@cecinc.com

**ARCHITECT**  
 ANSWERS, INC.  
 450 WEIDMANN ROAD  
 ST. LOUIS, MO 63011  
 PH: (636) 386-6707  
 CONTACT: MIKE RUPP  
 EMAIL: mrupp@answersinc.com

**LANDSCAPE**  
 ACDORN LANDSCAPES  
 PH: (636) 394-0255  
 CONTACT: MARY FRANCIS DEWEESE  
 EMAIL: deweees@acornlandscapes.com

**RECOMMENDED APPROVAL**  
 PLANNING & ZONING  
 CHAIRMAN

X SIGN. *[Signature]* DATE: 6-6-2022

DRAWING LIST		
#	TITLE	DESCRIPTION
01	SP01	COVER
02	SP02	SITE & GRADING PLAN
03	LA01	LANDSCAPE PLAN

**SURVEY CONTROL NOTES:**  
**BASIS OF BEARING:** THE BEARING SYSTEM HAS BEEN ADOPTED FROM GPS OBSERVATION, USING THE MISSOURI DEPARTMENT OF TRANSPORTATION'S NETWORK OF CONTINUOUSLY OPERATING REFERENCE SYSTEMS, ADJUSTED TO THE NAD83 STATE PLANE COORDINATE SYSTEM FOR THE STATE OF MISSOURI, EAST ZONE.  
**SITE DATUM ELEVATION:** HORIZONTAL AND VERTICAL CONTROL HAS BEEN ESTABLISHED BY GPS OBSERVATION USING MDDOT NETWORK, GEOID 12B ADJUSTMENTS AND NAVD83 IN FEET.

MISSOURI ONE CALL SYSTEM  
 811 or 1-800-344-7483  
 https://www.motcall.com  
 ISSUED TICKET # 050000000  
 TICKET DATE 05/19/2022



ENGINEER OF RECORD  
 (PE# XXXXXXXXXX)  
 \*HAND SIGNATURE ON FILE

NO	DATE	REVISION RECORD DESCRIPTION

**Civil & Environmental Consultants, Inc.**  
 CERTIFICATION/LICENSE NO. 2002013942  
 3000 Little Hills Expressway - Suite 102 - St. Charles, MO 63301  
 314-656-4566 - 866-250-3679  
 www.cecinc.com



**PANERA #617**  
 2375 NORTH HWY 67  
 FLORISSANT, MO 63033

DATE:	05/05/2022	DRAWN BY:	CAN
DWG SCALE:	AS NOTED	CHECKED BY:	DIRTB
PROJECT NO.:	316-917	APPROVED BY:	PTB

DRAWING NO: **SP01**  
 SHEET 01 OF 4

A:\2022-0001\2022-0001-C601\Draw\1001-001-001.dwg (1001-001-001.dwg) - 1/1 5/19/2022 11:28 AM







# PANERA #617 PLANTING PLAN

NORTH LINE OF OUTLOT PARCEL 1 OF AMENDED PIGEON PARK  
FLORISSANT - PLAT 2, PB 345, PG 495, ST. LOUIS COUNTY, MISSOURI

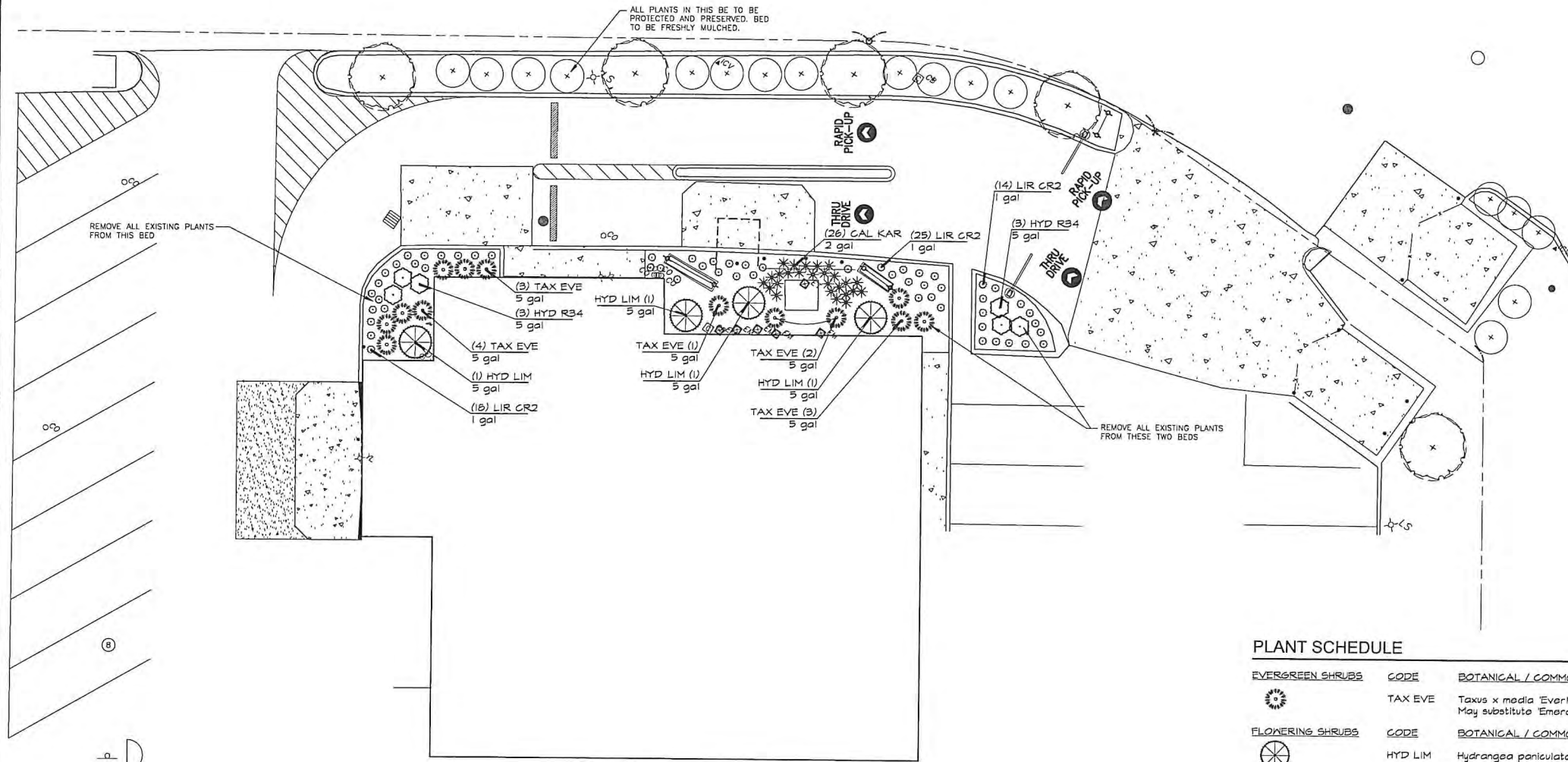

PRELIMINARY - NOT FOR CONSTRUCTION

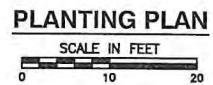

### PLANT SCHEDULE

EVERGREEN SHRUBS	CODE	BOTANICAL / COMMON NAME	CONT	QTY
	TAX EVE	Taxus x media 'Everlow' / Everlow Anglo-Japanese Yew May substitute 'Emerald Spreader' Yew	5 gal	13
FLOWERING SHRUBS	CODE	BOTANICAL / COMMON NAME	CONT	QTY
	HYD LIM	Hydrangea paniculata 'Limelight'™ / Limelight Hydrangea	5 gal	4
	HYD R34	Hydrangea quercifolia 'Ruby Slippers' / Ruby Slippers Oakleaf Hydrangea	5 gal	6
LOW GROUNDCOVER	CODE	BOTANICAL / COMMON NAME	CONT	QTY
	LIR CR2	Liriope spicata / Creeping Lilyturf do not substitute with any varieties of Liriope Muscari.	1 gal	51
ORNAMENTAL GRASS	CODE	BOTANICAL / COMMON NAME	CONT	QTY
	CAL KAR	Calamagrostis x acutiflora 'Karl Foerster' / Karl Foerster Feather Reed Grass	2 gal	26

NO	DATE	REVISION RECORD DESCRIPTION

**Civil & Environmental Consultants, Inc.**  
CERTIFICATION/LICENSE NO. 2002013942  
3000 Little Hills Expressway · Suite 102 · St. Charles, MO 63301  
314-656-4566 · 866-250-3679  
www.cecinc.com



**PANERA #617**  
2375 NORTH HWY 67  
FLORISSANT, MO 63033

DATE	DRAWN BY	DATE	DRAWN BY
05/09/2022	AS NOTED	316-917	PTB

PLANTING PLAN

LANDSCAPE ARCHITECT  
Mary Francois Dewese  
13 Forrester Dr.  
BALLYWIN, MO 63011  
(636)354-0255  
www.acornlandscapes.com



DRAWING NO.: **LA01**  
SHEET 01 OF 1





**GENERAL NOTES:**

- A. G.C. TO PROVIDE BLOCKING FOR SUPPORT OF RESTROOM ACCESSORIES AS RECOMMENDED BY MANUFACTURER. SEE INTERIOR ELEVATIONS.
- B. EXISTING OCCUPANCY LOAD SIGN TO REMAIN
- C. G.C. SHALL SUPPLY AND INSTALL RECESSED FIRE EXTINGUISHERS AS REQUIRED BY LOCAL CODES. LOCATION PER LOCAL CODES. (EXISTING)
- D. REFERENCE THE FOLLOWING SHEETS: G011 GENERAL NOTES, SYMBOLS, AND LEGENDS AND G021 ACCESSIBILITY GUIDELINES.
- E. ALL DIMENSIONS NOTED ARE FROM FACE OF DRYWALL TO FACE OF DRYWALL.
- F. BOOTH/BANQUETTE SEATING RE-FINISHED BY FURNITURE SUPPLIER. UNINSTALLED AND RE-INSTALLED BY G.C.
- G. ELECTRICAL EQUIPMENT BY G.C.
- H. PLUMBING EQUIPMENT BY G.C.
- I. G.C. TO VERIFY CONDITION OF ALL EXISTING DOOR HARDWARE AND CONFIRM IF REPLACEMENT IS REQUIRED.

**KEYED NOTES** INDICATED BY SYMBOL

- 102 INSTALL NEW/RELOCATED EQUIPMENT AS INDICATED.
- 104 INSTALL NEW DOOR WHERE EXISTING DRIVE THRU WINDOW WAS LOCATED.

**EQUIPMENT PLAN LEGEND:**

- XXX — ROOM NUMBER SYMBOL
- EQUIPMENT IDENTIFICATION SYMBOL
- STEEL IDENTIFICATION SYMBOL
- WOOD IDENTIFICATION SYMBOL
- REL — RELOCATION INDICATION SYMBOL
- FURNITURE IDENTIFICATION SYMBOL
- DOOR NUMBER SYMBOL
- FABRIC DESIGNATION SYMBOL (SEE A-4.8 SHEET)

**FURNITURE PLAN LEGEND:**

- XXX — ROOM NUMBER SYMBOL
- REL — RELOCATION INDICATION, ADDED TO SYMBOLS
- FURN-ID — FURNITURE IDENTIFICATION SYMBOL
- DOOR NUMBER SYMBOL
- FABRIC DESIGNATION SYMBOL

TYPICAL TABLE TAGGING EXAMPLE:

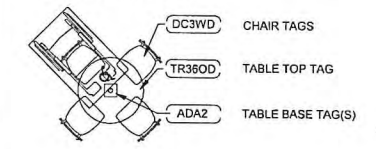

Bakery-Cafe:

**#617**

SYSTEM: G4 (ARIA)  
 Project Team:  
 DESIGN CONSULTANT:  
 ANSWERS, INC.  
 450 WEIDMAN ROAD  
 ST. LOUIS, MISSOURI 63011  
 636.386.6707

Professional Seal:

Project Title:

LIMITED SCOPE REMODEL  
**Bakery Cafe #617**  
**CONCEPT PLAN FOR**  
**REVIEW ONLY**  
 2375 NORTH HIGHWAY 67  
 FLOISSANT, MO 63033



Consultant Copyright Placeholder

No.	Description	Date

**FURNITURE / EQUIPMENT FLOOR PLAN**

Project Number: 22063  
 Drawn By: MRR  
 Issue Date: 04/22/2022  
 DPM: DM: CPM:  
 ANSWERS

Sheet Number:  
**A101**

4/22/2022 8:40:36 AM





INTRODUCED BY COUNCILMAN ROTH  
May 28, 1996

BILL NO. 6713

ORDINANCE NO. 5854

AN ORDINANCE AMENDING ORDINANCE NO. 5186 HERETOFORE GRANTED TO GRAMEX CORPORATION, AS AMENDED BY ORDINANCE NOS. 5472, 5697, 5733 AND 5749, FOR THE ESTABLISHMENT OF A B-5 PLANNED COMMERCIAL DISTRICT DEVELOPMENT SO AS TO AUTHORIZE A BOSTON MARKET RESTAURANT LOCATED ON OUTLOT PARCEL 1 AT THE GRAMEX DEVELOPMENT.

WHEREAS, Appendix B, of the Florissant City Code, known as the Zoning Ordinance of the Code of the City of Florissant as set out in Ordinance No. 1625 as amended, provides for the establishment of a B-5 Planned Commercial District; and

WHEREAS, the City Council of the City of Florissant heretofore established a B-5 Planned Commercial District for the property known as the Gramex Development under Ordinance No. 5186, as amended by Ordinance No. 5472 and subsequently amended by Ordinance Nos. 5697, 5733 and 5749; and

WHEREAS, after the adoption of Ordinance No. 5186, as amended by Ordinance Nos. 5472, 5697, 5733 and 5749, an application has been filed by Boston Chicken, Inc. requesting an amendment to allow for a sit-down, carry-out and drive-thru restaurant on Outlot Parcel 1 of the Gramex Development; and

WHEREAS, the Planning and Zoning Commission of the City of Florissant has recommended that said Ordinance No. 5186, as amended by Ordinance Nos. 5472, 5697, 5733 and 5749 be further amended to provide for development of Outlot Parcel 1 and to grant a Special Use Permit to Boston Chicken, Inc. for the operation of a sit-down, carry-out and drive-thru restaurant on such Outlot Parcel 1 under certain conditions; and

WHEREAS, due notice of a public hearing on said application to be held on the 13th day of May, 1996 at 8:00 p.m. by the City Council of the City of Florissant was duly published, held and concluded; and

WHEREAS, the Council, following said public hearing and after due and careful consideration has concluded that an amendment to Ordinance No. 5186, as amended by Ordinance Nos. 5472, 5697, 5733 and 5749, so as to allow for a sit-down, carry-out and drive-thru restaurant for Boston Chicken, Inc. on Outlot Parcel 1 of the Gramex Development would be in the best interest of the City of Florissant.

NOW, THEREFORE, BE IT ORDAINED BY THE COUNCIL OF THE CITY OF FLORISSANT, ST. LOUIS COUNTY, MISSOURI, AS FOLLOWS:

Section 1: Ordinance No. 5186 heretofore granted establishing a B-5 Planned Commercial District for the Gramex Development, as amended by Ordinance Nos. 5472, 5697, 5733 and 5749, is hereby further amended in the sections and manners noted herein.

Section 2: Ordinance No. 5186 heretofore granted establishing a B-5 Planned Commercial District for the Gramex Development, as amended by Ordinance Nos. 5472, 5697, 5733 and 5749, is hereby further amended by adding to subsection (12) "Development of Outlot Parcels" a new paragraph (b) to read as follows:

b) Outlot Parcel 1

- 1) A sit-down, carry-out and drive-thru restaurant for a Boston Market Restaurant may be located on the property identified as Outlot Parcel 1, as more fully depicted on the Site Plan, dated 3/29/96, a copy of which is attached hereto and made a part hereof as if fully set out herein and marked as Exhibit "A" and the Development Plan dated 3/15/96 and revised 3/28/96, a copy of which is attached hereto and made a part hereof as if fully set out herein and marked as Exhibit "B". Any proposed transfer of this restaurant use from Boston Chicken, Inc. d/b/a Boston Market may be addressed in the same manner and under the same procedure as the transfer of a Special Use Permit.
- 2) The total floor area of the building erected on Outlot Parcel 1 shall not exceed 4,599 square feet and the maximum height of the building shall be twenty (20) feet.
- 3) A sidewalk of at least five (5) foot minimum width shall be provided at and adjacent to all customers entrances. A five (5) foot walkway area shall be maintained along the length of such sidewalk upon which walkway area no outdoor or seasonal display shall be permitted.
- 4) The building shall be constructed of a grey masonry brick material with accents of a white split faced block and glass as shown on the drawings A2.1 and A2.2 dated 4/4/96 and revised 5/13/96, copies of which are attached hereto and made a part hereof as if fully set out herein and marked as Exhibit "C".
- 5) No freestanding signs other than directional signs to be installed as per the Site Plan shall be authorized on Outlot Parcel 1. That all signs on the building shall be as per the elevation drawings attached hereto and marked as Exhibit "C" and 1 menu board at the rear of the property for the drive-thru.
- 6) Mechanical equipment shall be screened as required and approved by the Planning and Zoning Commission.

- 7) The trash enclosure shall be constructed of the same brick as the building with a 6 foot gate.
- 8) The outside tables shall be located as per the A1.1 plan dated 4/4/96 attached hereto and made a part hereof as if fully set out herein and marked as Exhibit "D".
- 9) Adequate stormwater systems in accordance with accepted engineering standards shall be provided for stormwater drainage from Outlot Parcel 1. All required stormwater detention for such drainage shall be provided in permanent underground facilities. Permanent stormwater systems for Outlot Parcel 1 stormwater drainage shall be complete and operational prior to the issuance of any occupancy permit.
- 10) The landscaping shall be installed in accordance with the Landscape Plan dated 3/15/96 and revised 3/28/96, a copy of which is attached hereto and made a part hereof as if fully set out herein and marked as Exhibit "E".
- 11) That the lighting shall be installed in accordance with the photo-metrics submitted to the Planning & Zoning Commission on 4/15/96 and will be consistent with the lighting in the balance of the shopping center.
- 12) Completion of development of Outlot Parcel 1 shall be effected within one (1) year from the effective date of this ordinance.

Section 3: Except as herein amended, Ordinance No. 5186, as amended by Ordinance No. 5472, 5697, 5733 and 5749 shall remain in full force and effect.

Section 4: This ordinance shall become in full force and effect immediately upon its passage and approval.

Adopted this 10th day of June, 1996.

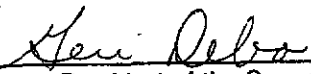
  
 \_\_\_\_\_  
 President of the Council  
 City of Florissant

Approved this 11 day of June, 1996.

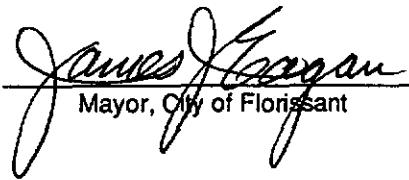
  
 \_\_\_\_\_  
 Mayor, City of Florissant

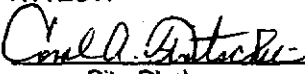
ATTEST:  
  
 \_\_\_\_\_  
 City Clerk

EXIST'G 54" W. ESMT.  
(P.B. 360, PG. 16)

40' BUILDING SETBACK  
EXIST' 10" W. SIDE  
ESMT. (P.B. 360,  
20' PARKING SE

(LINDBERGH BLVD.)

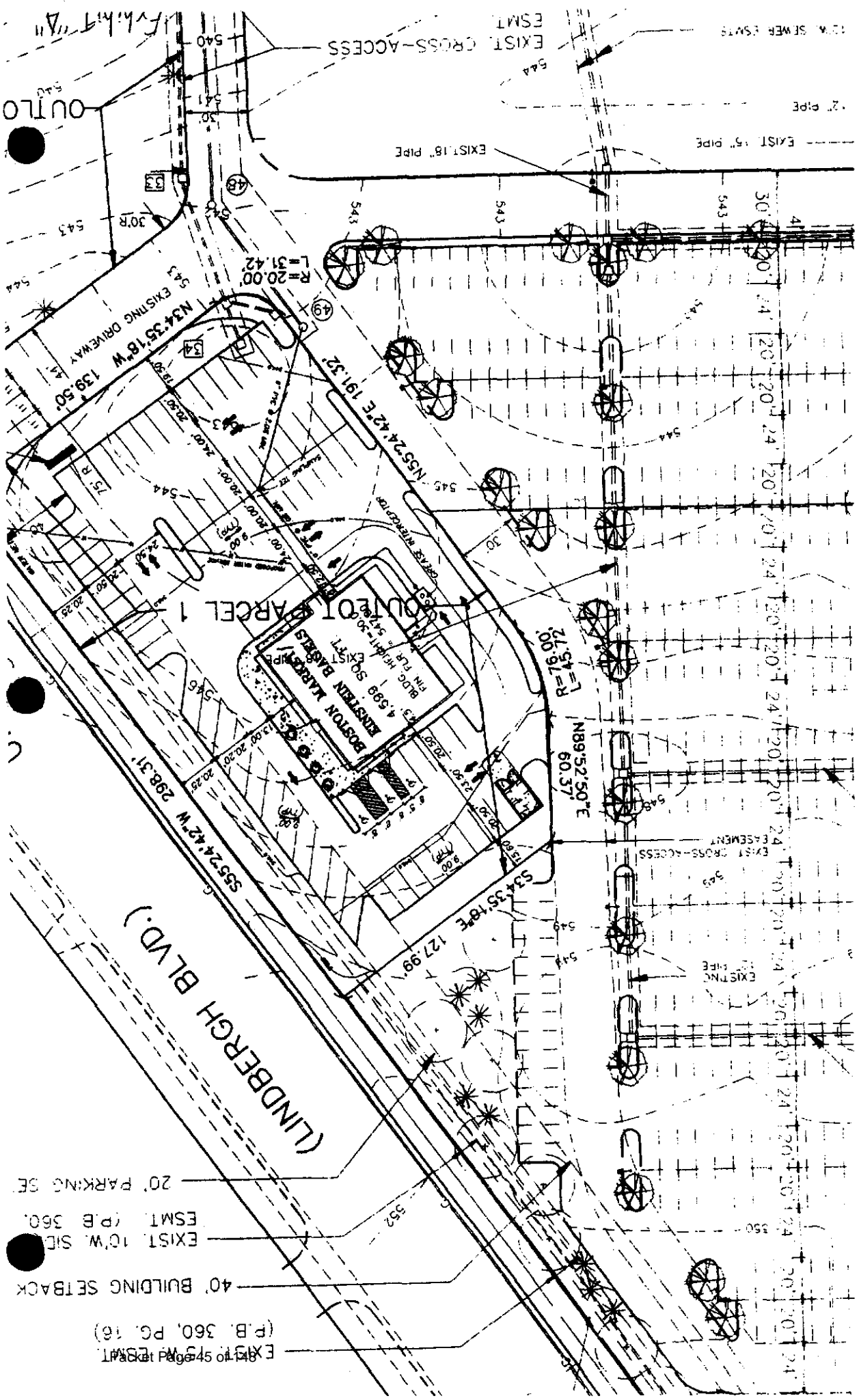

OUTLO

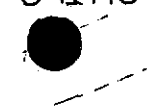





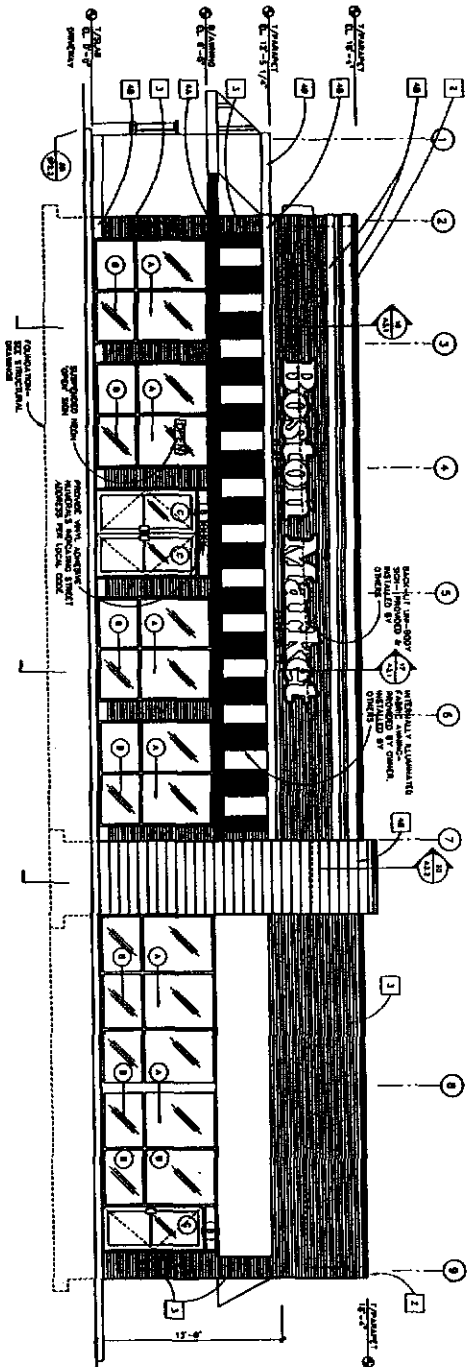

6 FRONT ELEVATION  
SCALE 1/8" = 1'-0"

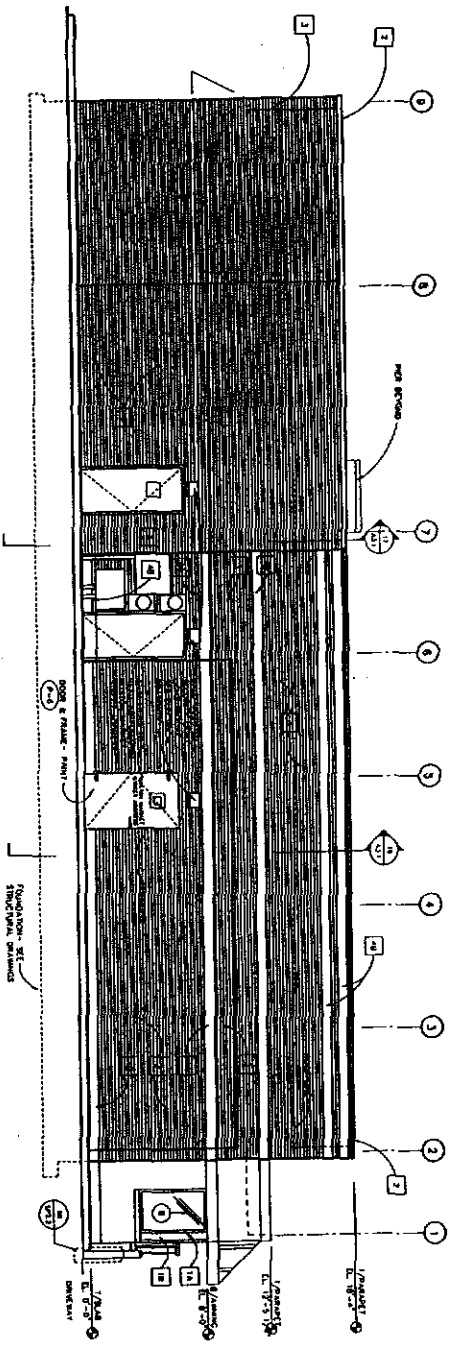

16 REAR ELEVATION  
SCALE 1/8" = 1'-0"

NO.	DESCRIPTION
1	GLASS TYPE ORIGINATOR
2	1" WALKING SURFACE
3	1" INSULATED GLASS WINDOW
4	1/4" EXPOSED BRICK

NO.	DESCRIPTION
5	EXTERIOR FINISH NOTES
6	ALUMINUM CLADDING - ANODIZED
7	ALUMINUM CLADDING - POLISHED
8	ALUMINUM CLADDING - MATT
9	ALUMINUM CLADDING - BRUSHED
10	ALUMINUM CLADDING - SATIN
11	ALUMINUM CLADDING - GLOSS
12	ALUMINUM CLADDING - ENAMEL
13	ALUMINUM CLADDING - PATTERN
14	ALUMINUM CLADDING - COLOR
15	ALUMINUM CLADDING - FINISH
16	ALUMINUM CLADDING - TYPE
17	ALUMINUM CLADDING - GRADE
18	ALUMINUM CLADDING - QUALITY
19	ALUMINUM CLADDING - MANUFACTURER
20	ALUMINUM CLADDING - SPECIFICATION

NO.	DESCRIPTION
15	MATERIAL LEGEND
16	FOUNDATION NOTES
17	GENERAL NOTES

NO.	DESCRIPTION
15	MATERIAL LEGEND
16	FOUNDATION NOTES
17	GENERAL NOTES

NO.	DESCRIPTION
20	GENERAL NOTES

**BOSTON MARKET**  
OUTLOT PARCEL 1, GRAMMEX  
FLORISSANT, MISSOURI

EXTERIOR ELEVATIONS

BOSTON COCCEN, INC.  
14102 Dorset Road, Parkway  
Columbia, Georgia 30606-1000

**TJ ARCHITECTS**

1111 N. 1st St.  
St. Louis, MO 63102  
314-241-1111



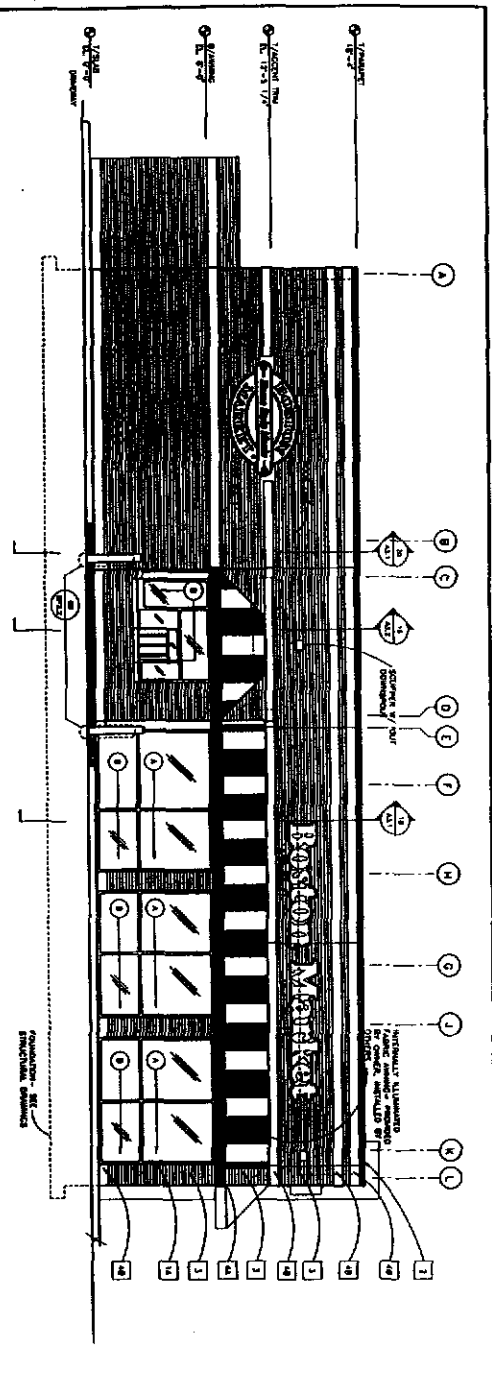

6 SIDE ELEVATION  
SCALE: 1/2" = 1'-0"

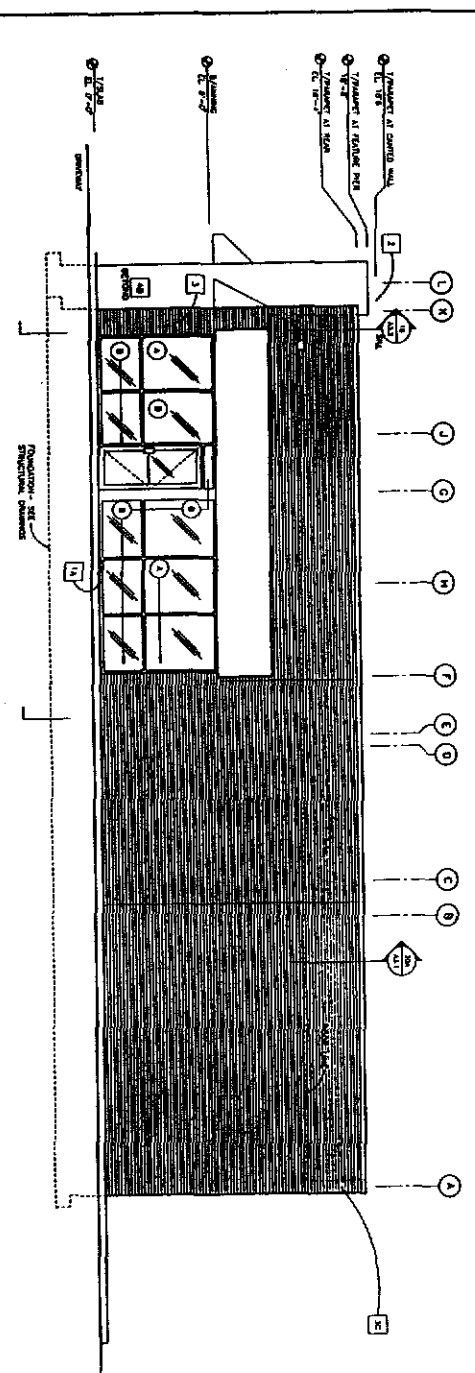

16 SIDE ELEVATION  
SCALE: 1/2" = 1'-0"

**NOTES:**  
1. ALL MATERIALS TO BE SUPPLIED BY THE CONTRACTOR.  
2. ALL MATERIALS TO BE SUPPLIED BY THE CONTRACTOR.  
3. ALL MATERIALS TO BE SUPPLIED BY THE CONTRACTOR.  
4. ALL MATERIALS TO BE SUPPLIED BY THE CONTRACTOR.

- 5 EXTERIOR FINISH NOTES**
- 1. 1/2" THICKNESS SLABS
  - 2. 1" THICKNESS SLABS
  - 3. 1" THICKNESS SLABS
  - 4. 1" THICKNESS SLABS
  - 5. 1" THICKNESS SLABS
  - 6. 1" THICKNESS SLABS
  - 7. 1" THICKNESS SLABS
  - 8. 1" THICKNESS SLABS
  - 9. 1" THICKNESS SLABS
  - 10. 1" THICKNESS SLABS
  - 11. 1" THICKNESS SLABS
  - 12. 1" THICKNESS SLABS
  - 13. 1" THICKNESS SLABS
  - 14. 1" THICKNESS SLABS
  - 15. 1" THICKNESS SLABS
  - 16. 1" THICKNESS SLABS
  - 17. 1" THICKNESS SLABS
  - 18. 1" THICKNESS SLABS
  - 19. 1" THICKNESS SLABS
  - 20. 1" THICKNESS SLABS

- 15 MATERIAL LEGEND**
- SCALE: 1/2" = 1'-0"
- 1. ALL SPACING AND BRACING SHALL BE AS SHOWN ON SHEET 11.7 FOR COLUMN.
  - 2. LOCATION & SIZE OF SPACING TO BE FIELD CONNECTIONS SHALL BE AS SHOWN ON SHEET 11.7 FOR COLUMN.
  - 3. LOCATION & SIZE OF SPACING TO BE FIELD CONNECTIONS SHALL BE AS SHOWN ON SHEET 11.7 FOR COLUMN.
  - 4. LOCATION & SIZE OF SPACING TO BE FIELD CONNECTIONS SHALL BE AS SHOWN ON SHEET 11.7 FOR COLUMN.
  - 5. LOCATION & SIZE OF SPACING TO BE FIELD CONNECTIONS SHALL BE AS SHOWN ON SHEET 11.7 FOR COLUMN.
  - 6. LOCATION & SIZE OF SPACING TO BE FIELD CONNECTIONS SHALL BE AS SHOWN ON SHEET 11.7 FOR COLUMN.
  - 7. LOCATION & SIZE OF SPACING TO BE FIELD CONNECTIONS SHALL BE AS SHOWN ON SHEET 11.7 FOR COLUMN.
  - 8. LOCATION & SIZE OF SPACING TO BE FIELD CONNECTIONS SHALL BE AS SHOWN ON SHEET 11.7 FOR COLUMN.
  - 9. LOCATION & SIZE OF SPACING TO BE FIELD CONNECTIONS SHALL BE AS SHOWN ON SHEET 11.7 FOR COLUMN.
  - 10. LOCATION & SIZE OF SPACING TO BE FIELD CONNECTIONS SHALL BE AS SHOWN ON SHEET 11.7 FOR COLUMN.
  - 11. LOCATION & SIZE OF SPACING TO BE FIELD CONNECTIONS SHALL BE AS SHOWN ON SHEET 11.7 FOR COLUMN.
  - 12. LOCATION & SIZE OF SPACING TO BE FIELD CONNECTIONS SHALL BE AS SHOWN ON SHEET 11.7 FOR COLUMN.
  - 13. LOCATION & SIZE OF SPACING TO BE FIELD CONNECTIONS SHALL BE AS SHOWN ON SHEET 11.7 FOR COLUMN.
  - 14. LOCATION & SIZE OF SPACING TO BE FIELD CONNECTIONS SHALL BE AS SHOWN ON SHEET 11.7 FOR COLUMN.
  - 15. LOCATION & SIZE OF SPACING TO BE FIELD CONNECTIONS SHALL BE AS SHOWN ON SHEET 11.7 FOR COLUMN.
  - 16. LOCATION & SIZE OF SPACING TO BE FIELD CONNECTIONS SHALL BE AS SHOWN ON SHEET 11.7 FOR COLUMN.
  - 17. LOCATION & SIZE OF SPACING TO BE FIELD CONNECTIONS SHALL BE AS SHOWN ON SHEET 11.7 FOR COLUMN.
  - 18. LOCATION & SIZE OF SPACING TO BE FIELD CONNECTIONS SHALL BE AS SHOWN ON SHEET 11.7 FOR COLUMN.
  - 19. LOCATION & SIZE OF SPACING TO BE FIELD CONNECTIONS SHALL BE AS SHOWN ON SHEET 11.7 FOR COLUMN.
  - 20. LOCATION & SIZE OF SPACING TO BE FIELD CONNECTIONS SHALL BE AS SHOWN ON SHEET 11.7 FOR COLUMN.

- 20 GENERAL NOTES**
- SCALE: 1/2" = 1'-0"
- 1. FOUNDATION NOTES
  - 2. FOUNDATION NOTES
  - 3. FOUNDATION NOTES
  - 4. FOUNDATION NOTES
  - 5. FOUNDATION NOTES
  - 6. FOUNDATION NOTES
  - 7. FOUNDATION NOTES
  - 8. FOUNDATION NOTES
  - 9. FOUNDATION NOTES
  - 10. FOUNDATION NOTES
  - 11. FOUNDATION NOTES
  - 12. FOUNDATION NOTES
  - 13. FOUNDATION NOTES
  - 14. FOUNDATION NOTES
  - 15. FOUNDATION NOTES
  - 16. FOUNDATION NOTES
  - 17. FOUNDATION NOTES
  - 18. FOUNDATION NOTES
  - 19. FOUNDATION NOTES
  - 20. FOUNDATION NOTES

**BOSTON MARKET**  
OUTLOT PARCEL 1, GRAMMEX  
FLORISSANT, MISSOURI

EXTERIOR ELEVATIONS

BOSTON CHICKEN, INC.  
11400 River Road Parkway  
Crestwood, MO 63114

**TU ARCHITECTS**

11400 River Road Parkway  
Crestwood, MO 63114

Packet Page 4 of 8



1 INTRODUCED BY COUNCILMAN HERNANDEZ  
2 JULY 24, 2006

3  
4 BILL NO. 8235

ORDINANCE NO. 7322

5  
6  
7 **AN ORDINANCE AMENDING B-5 ORDINANCE NO. 5854 FOR**  
8 **PANARA LLC. TO ALLOW FOR A DRIVE THRU FACILITY AND**  
9 **ADDITIONAL SIGNAGE FOR THE PROPERTY LCOATED AT 2375 N.**  
10 **HIGHWAY 67.**

11  
12  
13 WHEREAS, the Planning and Zoning Commission of the City of Florissant has  
14 recommended to the City Council at their meeting of July 6, 2006 that Ordinance No. 5854 be  
15 amended to allow for the addition of a drive thru facility and additional signage; and

16 WHEREAS, due and lawful notice of a public hearing on said proposed change was duly  
17 published, held and concluded on 24<sup>th</sup> of July, 2006 by the Council of the City of Florissant; and

18 WHEREAS, the Council, following said public hearing, and after due and careful  
19 deliberation, has concluded that the amendment of Ordinance No. 5854, as hereinafter set forth,  
20 to be in the best interest of the public health, safety and welfare of the City of Florissant; and

21 NOW, THEREFORE, BE IT ORDAINED BY THE COUNCIL OF THE CITY OF  
22 FLORISSANT, ST. LOUIS COUNTY, MISSOURI, AS FOLLOWS:

23  
24  
25 Section 1: Ordinance No. 5854 heretofore granted to Panera, LLC for a B-5 Planned  
26 Commercial District Development is hereby amended to allow for the addition of a drive thru  
27 facility and additional signage in accordance with the drawings dated 6/12/06. Copies of which  
28 are attached hereto and made a part hereof as if fully set out herein.

29  
30  
31 Section 2: Except as herein amended Ordinance No. 5854 shall remain in full force and  
32 effect.

33 Section 3: This ordinance shall become in full force and effect immediately upon its  
34 passage and approval.

35  
36 Adopted this 14 day of August, 2006.

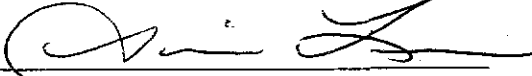
37  
38   
39 Tim Lee  
40 President of the Council

41  
42  
43  
44  
45  
46  
47  
48  
49  
50  
51  
52

Approved this 12 day of August, 2006.

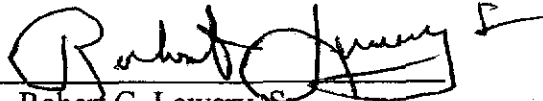
  
Robert G. Lowery, Sr.  
Mayor, City of Florissant

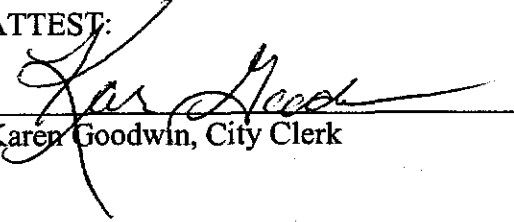
ATTEST:  
  
Karen Goodwin, City Clerk

BAKERY CAFE #617  
DESIGN CONSULTANT  
ANSWERS, INC.

DESIGN CONSULTANT  
ANSWERS, INC.  
ANSWERS, INC.  
ANSWERS, INC.  
ANSWERS, INC.



BAKERY CAFE #617  
DESIGN CONSULTANT  
ANSWERS, INC.

REVISION table with columns for revision number and description.

SHEET NO. SDP-10  
6-12-06

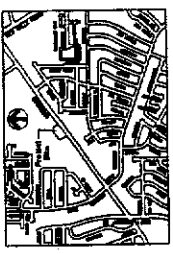
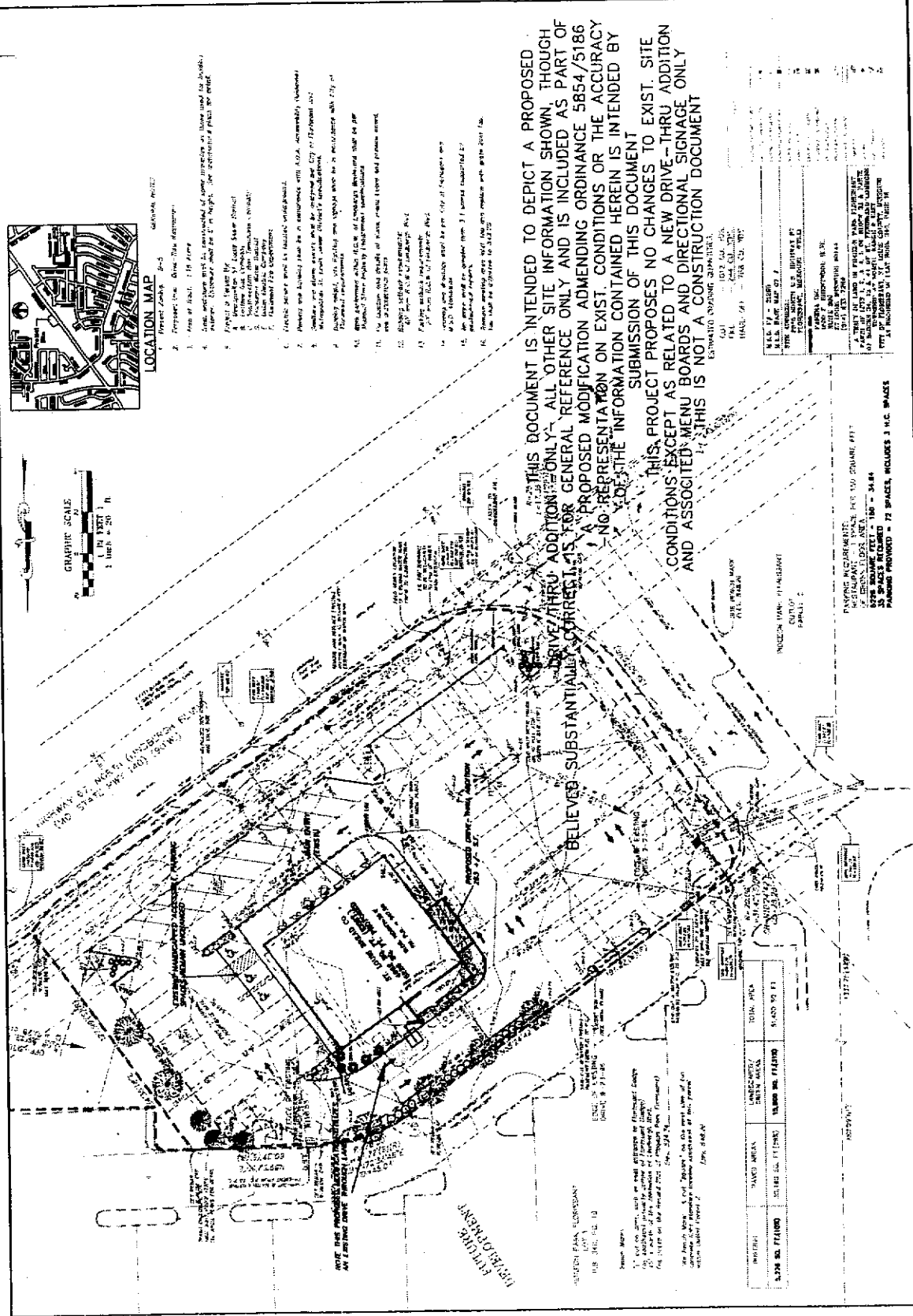

LOCATION MAP

- 1. Project Name: Bakery Cafe #617
2. Project Location: 112th Street, St. Louis, MO
3. Site Area: 1.18 Acres
4. Site Address: 112th Street, St. Louis, MO
5. Project Description: Bakery Cafe #617
6. Project Owner: Baker's Choice, Inc.
7. Project Architect: Answers, Inc.
8. Project Engineer: James H. Hester, P.E.
9. Project Date: 6/12/06
10. Project No.: SDP-10

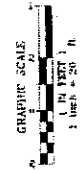

THIS DOCUMENT IS INTENDED TO DEPICT A PROPOSED DRIVE-THRU ADDITION TO THE EXISTING BUILDING SHOWN, THROUGH BELIEVED SUBSTANTIAL CORRECT. THIS PROJECT PROPOSES NO CHANGES TO EXIST. SITE CONDITIONS EXCEPT AS RELATED TO A NEW DRIVE-THRU ADDITION AND ASSOCIATED MENU BOARDS AND DIRECTIONAL SIGNAGE ONLY. THIS IS NOT A CONSTRUCTION DOCUMENT.

Table with columns: PROPERTY, TRACT AREA, UNDEVELOPED TRACT AREA, TOTAL AREA, ACRES. Row 1: 5.728 SQ. FT. (0.131 AC), 10,000 SQ. FT. (0.229 AC), 15,728 SQ. FT. (0.359 AC).

PARKING REQUIREMENTS: 33 SPACES REQUIRED. RESTAURANT - 3 SPACES PER 100 SQUARE FEET. DRIVE-THRU - 1 SPACE PER 100 SQUARE FEET. 33 SPACES REQUIRED.

ESTIMATED ENGINEERING FEE: \$10,000.00. TOTAL FEE: \$10,000.00.



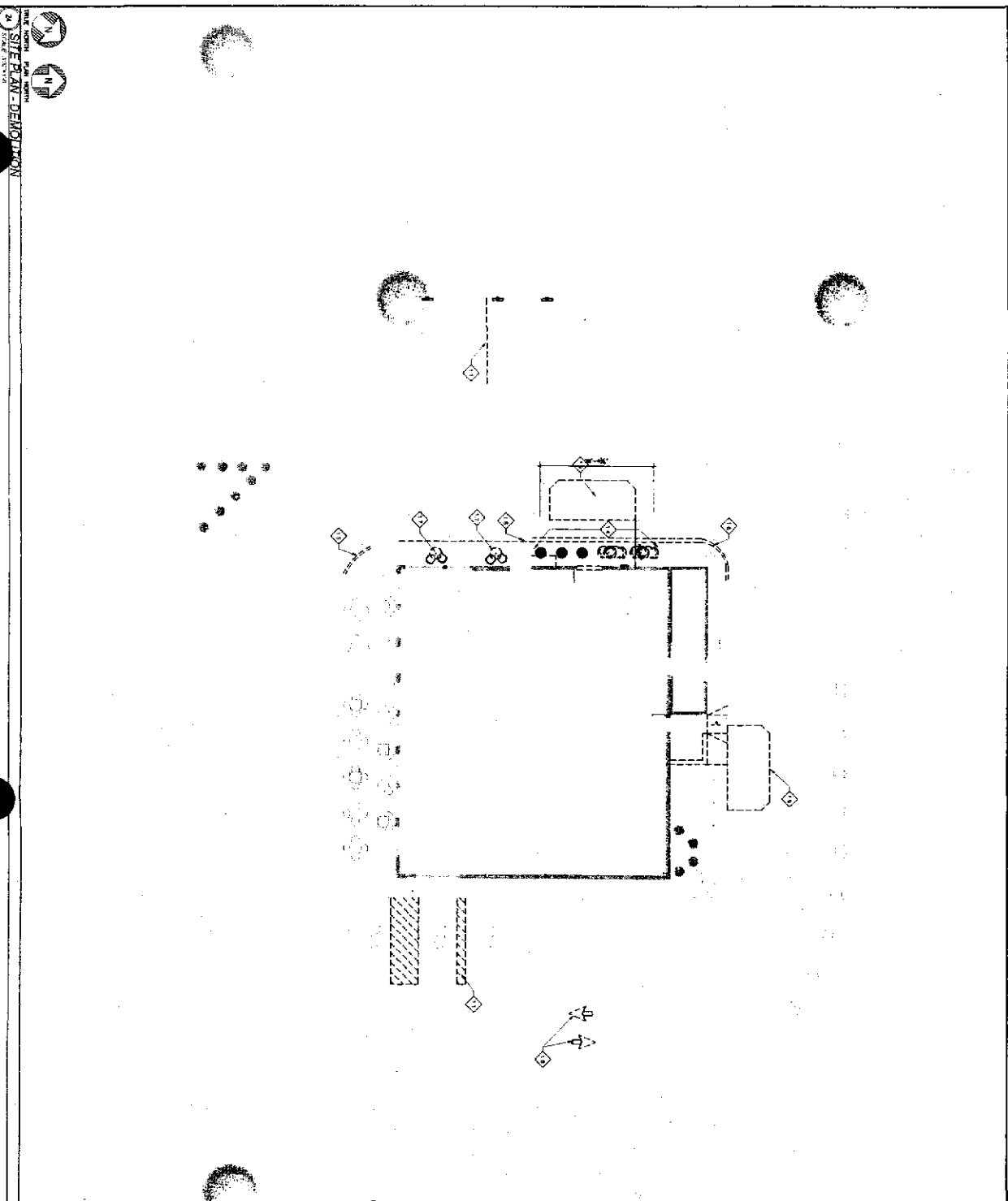

GENERAL NOTES:

KEYED NOTES:

- ◆ REMOVE EXISTING DRIVEWAY AS INDICATED IN PREPARATION FOR NEW DRIVEWAY.
- ◆ REMOVE EXISTING LANDSCAPING, CONCRETE & ASPHALT IN PREPARATION FOR DRIVE THRU ADJUSTMENT.
- ◆ REMOVE EXISTING CURB IN PREPARATION FOR ADA COMPLIANCE.
- ◆ REMOVE EXISTING CURB IN PREPARATION FOR DRIVE THRU ADJUSTMENT.
- ◆ REMOVE EXISTING DRIVEWAY AS INDICATED IN PREPARATION FOR NEW DRIVEWAY.
- ◆ REMOVE EXISTING DRIVEWAY AS INDICATED IN PREPARATION FOR NEW DRIVEWAY.
- ◆ REMOVE EXISTING DRIVEWAY AS INDICATED IN PREPARATION FOR NEW DRIVEWAY.
- ◆ REMOVE EXISTING DRIVEWAY AS INDICATED IN PREPARATION FOR NEW DRIVEWAY.
- ◆ REMOVE EXISTING DRIVEWAY AS INDICATED IN PREPARATION FOR NEW DRIVEWAY.
- ◆ REMOVE EXISTING DRIVEWAY AS INDICATED IN PREPARATION FOR NEW DRIVEWAY.

RECOMMENDED APPROVAL  
PLANNING & ZONING  
CHAIRMAN

SIGN: *Michael A. Perry* DATE: *7/6/04*



**BAKERY CAFE #617**  
02 DRIVEWAY ADJUSTMENT  
03 LANDSCAPING ADJUSTMENT  
04 CONCRETE & ASPHALT ADJUSTMENT

DESIGN CONSULTANT, ARCHITECT, ME/P ENGINEER  
**ANSWERS, INC.**  
ARCHITECT  
ANSWERS, INC.  
11101 W. STATE ST. SUITE 100  
FLORISSANT, MO 63033  
636.227.1111  
636.227.1112

**BAKERY CAFE #617**  
5% REVIEW DOCUMENTS -  
REMODEL DRIVE THRU  
2376 NORTH HIGHWAY 67  
FLORISSANT, MO 63033

REVISION

SHEET NO.  
**A-1.0**  
DATE: 7/6/04  
SCALE: AS SHOWN

1 INTRODUCED BY COUNCILMAN HERNANDEZ  
2 MARCH 25, 2013

3  
4 BILL NO. 8908

ORDINANCE NO.

7962

5  
6  
7 **AN ORDINANCE AMENDING B-5 ORDINANCE NO. 5854 AS**  
8 **AMENDED BY ORDINANCE NO. 7322 FOR PANARA LLC. TO**  
9 **ALLOW FOR THE REPLACEMENT OF AN EXISTING WALL SIGN**  
10 **FOR THE PROPERTY LCOATED AT 2375 N. HIGHWAY 67.**  
11

12  
13 WHEREAS, the Planning and Zoning Commission of the City of Florissant has  
14 recommended to the City Council at their meeting of March 4, 2013 that Ordinance No. 5854 as  
15 amended by Ordinance No. 7322 be amended to allow for the replacement of an existing wall  
16 sign; and

17 WHEREAS, due and lawful notice of a public hearing no. 13-03-010 on said proposed  
18 change was duly published, held and concluded on the 25<sup>th</sup> day of March, 2013 by the Council  
19 of the City of Florissant; and

20 WHEREAS, the Council, following said public hearing, and after due and careful  
21 deliberation, has concluded that the amendment of Ordinance No. 5854, as amended by  
22 Ordinance No. 7322 as hereinafter set forth, to be in the best interest of the public health, safety  
23 and welfare of the City of Florissant; and

24 NOW, THEREFORE, BE IT ORDAINED BY THE COUNCIL OF THE CITY OF  
25 FLORISSANT, ST. LOUIS COUNTY, MISSOURI, AS FOLLOWS:  
26

27  
28 Section 1: Ordinance No. 5854 as amended by Ordinance No. 7322 heretofore granted  
29 to Panera, LLC for a B-5 Planned Commercial District Development is hereby amended to allow  
30 for the replacement of an existing wall sign in accordance with the drawings dated 4/30/12.  
31 Copies of which are attached hereto and made a part hereof as if fully set out herein.  
32

33 Section 2: Except as herein amended Ordinance No. 5854 as amended by Ordinance no.  
34 7322 shall remain in full force and effect.

35 Section 3: This ordinance shall become in full force and effect immediately upon its  
36 passage and approval.



37

38

39

40

41

Adopted this 25 day of March, 2013.

42

43

44

45

46

  
\_\_\_\_\_  
Keith Schildroth  
President of the Council

47

Approved this 26 day of MARCH, 2013.

48

49

50

51

52

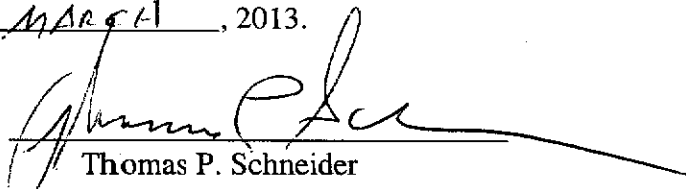
  
\_\_\_\_\_  
Thomas P. Schneider  
Mayor, City of Florissant

53

ATTEST:

54

55

56

  
\_\_\_\_\_  
Karen Goodwin, MMC/MRCC  
City Clerk

57

58

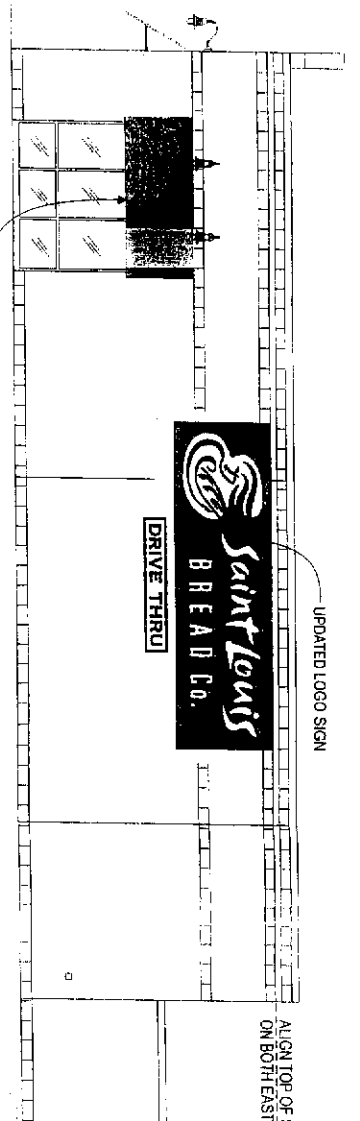

EAST ELEVATION  
1/8" = 1'-0"  
REPLACE EXISTING STRIPED FABRIC COVERS  
USING G2 WHEAT DESIGN. SEE DETAILS ON W-132d



SIGN ELEVATION: 1/4" = 1'-0"  
MAIN SIGN SPECS. ON SHEET: W-132b

ALIGN TOP OF SIGNS  
ON BOTH EAST AND WEST ELEVATIONS

RECOMMENDED APPROVAL  
PLANNING & ZONING  
CHAIRMAN  
SIGN *final* DATE: 3/1/13

Wall size  
approx 13' tall x 80' wide

- ILLUMINATED 'DRIVE THRU' SIGN CABINET:
- ALUMINUM CHANNEL LETTER TYPE CONSTRUCTION
  - 040 ALUM. RETURNS, 5" DEEP PAINTED BLACK
  - 3/16" THICK WHITE ACRYLIC FACE
  - 230-22 MATTE BLACK VINYL COPY
  - 1" X 3/8" ALUM. T-RETAINER PAINTED BLACK
  - 2" DEEP ALUM. PAN BKGD. PANEL PAINTED PMS 575/TU
  - WHITE LED ILLUMINATION
  - WEEP HOLES REQUIRED
  - LOW VOLTAGE POWER SUPPLY
  - FLUSH WALL MOUNT
  - ULL LABEL

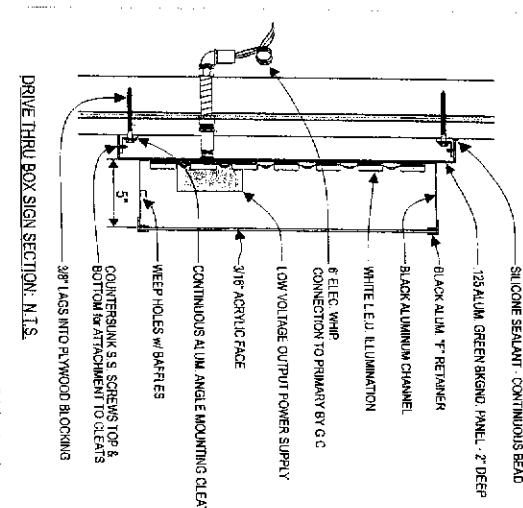

DRIVE THRU BOX SIGN SECTION: N.T.S.



MANDENVILLE SIGN  
576 GEORGE WASHINGTON HIGHWAY  
LINDSEY, RI 02885-4255

401-334-9100  
401-334-7939  
www.mandevillesign.com

REVISIONS

NO	BY	DESCRIPTION	DATE
1	WJD	Issue Sign	03-02-12

23264-1  
617  
2375 Highway 67 North  
FLORISSANT MO

JACK P.  
W-132c  
NOTED



1 INTRODUCED BY COUNCILMAN MULCAHY  
2 JUNE 13, 2022

3  
4 BILL NO. 9791

ORDINANCE NO.

5  
6  
7  
8  
9

**AN ORDINANCE VACATING A PORTION OF BROWN STREET  
AT ST. JOSEPH (A PAPER STREET)**

10 WHEREAS , a street known as a portion of Brown Street was dedicated to the  
11 city but has not been used as a public street; and

12 WHEREAS, the Mayor and City Council believe it to be in the best interest of  
13 the City to vacate that portion of Brown Street that has not been used as a public  
14 street.

15

16 BE IT ORDAINED BY THE COUNCIL OF THE CITY OF FLORISSANT, ST. LOUIS  
17 COUNTY, MISSOURI, AS FOLLOWS:

18

19 Section 1: The City of Florissant hereby vacate portions of Brown Street running north  
20 to south from St. Joseph St. (a paper street) as more particularly identified in the attached area  
21 map.

22 Section 2: This ordinance shall become in full force and effect immediately upon its  
23 passage and approval.

24

25

26 Adopted this \_\_\_\_\_ day of \_\_\_\_\_, 2022.

27

28

29

\_\_\_\_\_  
Joseph Eagan  
President of the City Council

30

31

32 Approved this \_\_\_\_\_ day of \_\_\_\_\_, 2022.

33

34

35

\_\_\_\_\_  
Timothy J. Lowery  
Mayor

36

37 ATTEST:

38

39

40 \_\_\_\_\_  
Karen Goodwin, MMC, MRCC  
41 City Clerk

**FLORISSANT CITY COUNCIL  
AGENDA REQUEST FORM**

6/9/2022	<b>Mayor's Approval:</b>																																				
Agenda Date Requested: 6/13/2022																																					
Description of request: Vacation of Brown Street at St. Joseph Street																																					
Transfer of Funds from (See Attached Memo)																																					
Department: Public Works																																					
Recommending Board or Commission: N/A																																					
<b>Type of request:</b>	<table border="1" style="width:100%; border-collapse: collapse;"> <thead> <tr> <th style="width:50%;">Ordinances</th> <th style="width:5%;">X</th> <th style="width:40%;">Other</th> <th style="width:5%;"></th> </tr> </thead> <tbody> <tr> <td>Appropriation</td> <td></td> <td>Liquor License</td> <td></td> </tr> <tr> <td>Transfer</td> <td></td> <td>Hotel License</td> <td></td> </tr> <tr> <td>Zoning Amendment</td> <td></td> <td>Special Presentations</td> <td></td> </tr> <tr> <td>Amendment</td> <td></td> <td>Resolution</td> <td></td> </tr> <tr> <td>Special Use Transfer</td> <td></td> <td>Proclamation</td> <td></td> </tr> <tr> <td>Special Use</td> <td></td> <td>Subdivision</td> <td align="center"><b>x</b></td> </tr> <tr> <td>Budget Amendment</td> <td></td> <td></td> <td></td> </tr> <tr> <td></td> <td align="center">Y/N</td> <td></td> <td align="center">Y/N</td> </tr> </tbody> </table>	Ordinances	X	Other		Appropriation		Liquor License		Transfer		Hotel License		Zoning Amendment		Special Presentations		Amendment		Resolution		Special Use Transfer		Proclamation		Special Use		Subdivision	<b>x</b>	Budget Amendment					Y/N		Y/N
	Ordinances	X	Other																																		
	Appropriation		Liquor License																																		
	Transfer		Hotel License																																		
	Zoning Amendment		Special Presentations																																		
	Amendment		Resolution																																		
	Special Use Transfer		Proclamation																																		
	Special Use		Subdivision	<b>x</b>																																	
Budget Amendment																																					
	Y/N		Y/N																																		
Public Hearing needed: Yes / No	<b>N</b> 3 readings?: Yes / No																																				
<table border="1" style="width:100%; border-collapse: collapse;"> <thead> <tr> <th style="width:50%;">Back up materials attached:</th> <th style="width:5%;"></th> <th style="width:40%;">Back up materials needed:</th> <th style="width:5%;"></th> </tr> </thead> <tbody> <tr> <td>Minutes</td> <td></td> <td>Minutes</td> <td></td> </tr> <tr> <td>Maps</td> <td></td> <td>Maps</td> <td></td> </tr> <tr> <td>Memo</td> <td align="center"><b>X</b></td> <td>Memo</td> <td></td> </tr> <tr> <td>Draft Ord.</td> <td></td> <td>Draft Ord.</td> <td></td> </tr> </tbody> </table>	Back up materials attached:		Back up materials needed:		Minutes		Minutes		Maps		Maps		Memo	<b>X</b>	Memo		Draft Ord.		Draft Ord.																		
Back up materials attached:		Back up materials needed:																																			
Minutes		Minutes																																			
Maps		Maps																																			
Memo	<b>X</b>	Memo																																			
Draft Ord.		Draft Ord.																																			
<p><b>Note:</b> Please include all attachments necessary for documents to be generated for inclusion on the Agenda. All agenda requests are to be turned in to the City Clerk by 5pm on Tuesday prior to the Council meeting.</p>	<p><b>For City Clerk Use Only:</b>            Introduced by: _____            PH Speaker: _____</p>																																				

Mr. & Mrs. Joe Meyer  
985 St. Joseph St.  
Florissant MO 63031

Attn: City Council  
City of Florissant  
955 St Francois St.  
Florissant MO 63031

To Mayor Tim Lowery and City Council,

We are formally requesting the vacation of the easement best described as Brown Street running north to south from St. Joseph St. This paper street easement is currently grass, landscaping, and some small trees. The vacation of the property would allow us to develop our property at 985 St Joseph St. We have consulted with Tom Goldkamp and other city officials to understand the best process for this, and will continue to work with Tom, and anyone else in public works to comply with city code.

Thank you for your consideration,

X 

Mr. Joseph Meyer

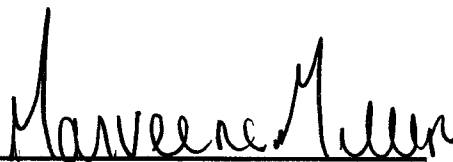
X 

Notary

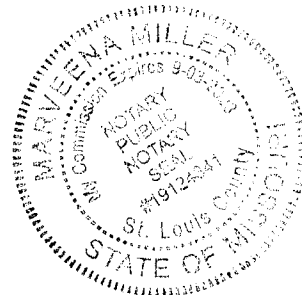

# Vacation Area Map

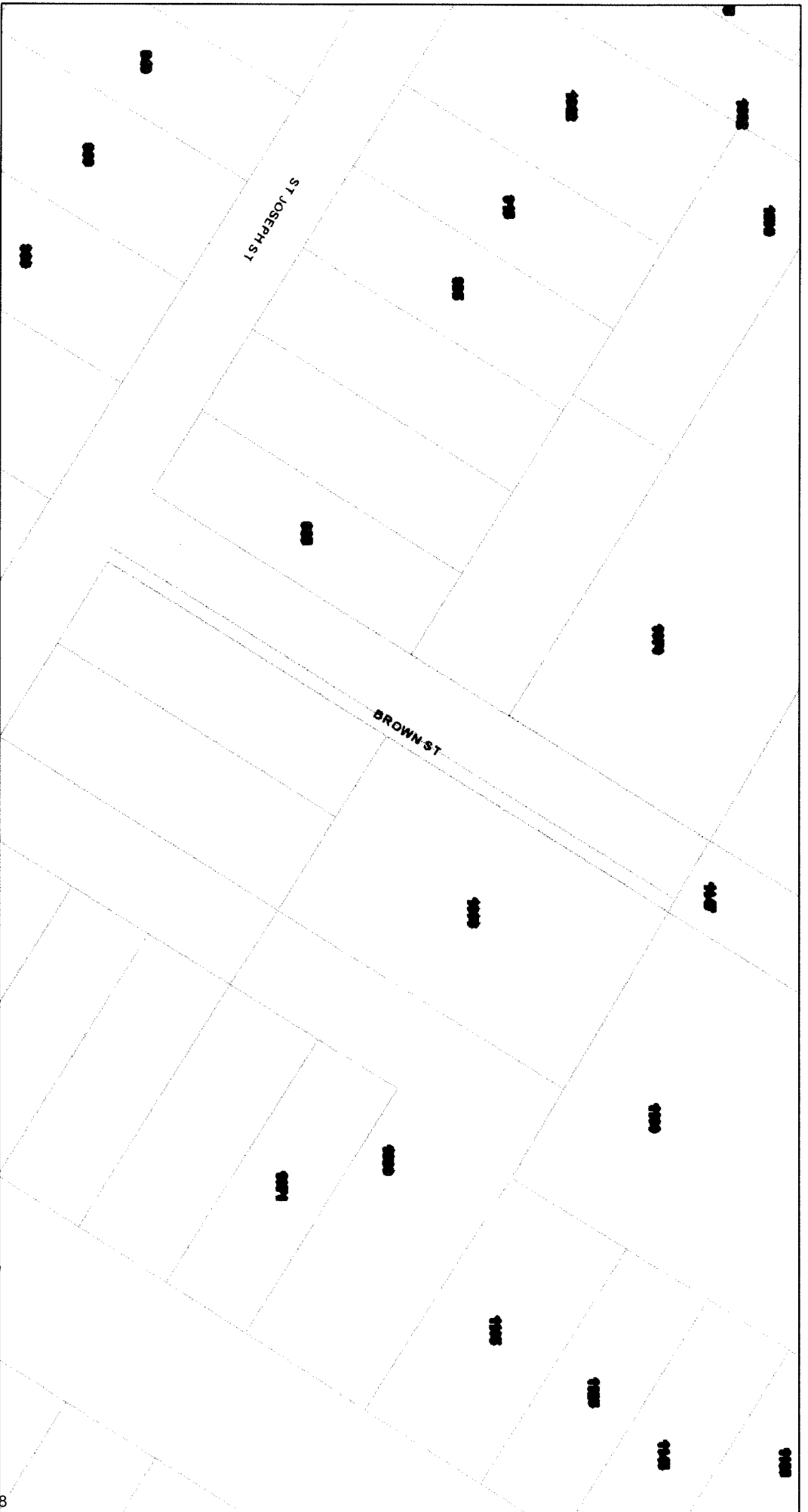

6/8/2022, 3:24:18 PM

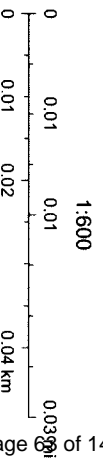

St. Louis County GIS Service Center

**CITY OF FLORISSANT**

955 rue St. Francois  
314-921-5700

**APPLICATION FOR LIQUOR LICENSE**

**TYPE OF LICENSE REQUESTED:**

- Full Liquor by the Drink
- Malt Liquor & Wine by the Drink
- Full Liquor by Drink (Non-Profit)
- Full Package Liquor
- Malt Liquor & Wine Package
- Consumption of Liquor
- Tasting

**To the City Clerk, City of Florissant, Saint Louis County Missouri:**

The undersigned hereby makes application for a liquor license issued under Chapter 600 of the Florissant City Code

**TYPE OF LICENSE REQUESTED:**

- Individual
- Partnership (Attach list of Partners)
- Corporation (Attach list of officers, addresses)
- Limited Liability Corp

**Name of Business** DoorDash Essentials

**Business Address** 1 Paddock Hills Shopping Center, Unit 1D Phone \_\_\_\_\_

**Names of Applicant, Corporation, or LLC** DoorDash Essentials LLC

**Address of Owner** PO Box 456, Jefferson City, MO 65102 (mailing address) Phone 573-635-7166  
Street City State Zip

**Name of Managing Officer** Lorene Williams

**Home Address** 4827 Sunrise Dr. Jefferson City MO 65101 Years at address 2  
Street City/State Zip Home Phone

**Managing Officer** Date & Place of Birth 01/15/77 St. Louis, MO Cell Phone 573-619-7643

**Managing Officer** Driver's License No. [REDACTED] Social Security Number\* [REDACTED]  
(Provide a copy of driver's license) \* Social Security Number used for purposes of identification in running record check.

**Managing Officer** Personal Property Taxes 20  Paid?  Yes ( ) No (Attach most recent copy)

**Managing Officer** Register Voter of Missouri?  Yes ( ) No (Attach a Voter Registration Certificate)

Have you ever been arrested? No What Charge? \_\_\_\_\_  
Where? \_\_\_\_\_ Disposition? \_\_\_\_\_

Citizen of U.S.A.?  Yes ( ) No Naturalized? ( ) Yes Date \_\_\_\_\_  No  
If Naturalized, Give Number: \_\_\_\_\_ Dist. \_\_\_\_\_  
(Provide naturalization documentation)

Do you have an interest in any liquor license which is now in force? None other than as managing officer  
If so, give details \_\_\_\_\_

Have you previously held a liquor license of any type? As managing officer only  
If so, when and where \_\_\_\_\_



Have you ever had a liquor license suspended or revoked? No  
If so, give details \_\_\_\_\_

Have you ever been convicted of any violation of any federal or state law? No  
If so, give details \_\_\_\_\_

Have you ever been convicted of any municipal or county ordinance violation? No  
If so, give details \_\_\_\_\_

Have you ever been convicted of any violation of a federal law, state statute or local ordinance relating to intoxicating liquor? No  
If so, give details \_\_\_\_\_

Has the location previously been occupied as a liquor establishment, liquor store or tavern? No  
If so, state name \_\_\_\_\_

Is the location within 200 feet of property used for church, school or public playground? No

If Individual Applicant, sign below:

If Partnership, corporation or LLC complete the following:

DoorDash Essentials

Trade Name \_\_\_\_\_

\_\_\_\_\_  
**Signature of Managing Officer**

STATE OF MISSOURI ) SS  
COUNTY OF ST. LOUIS )

Lorene Williams, of lawful age, being first duly sworn upon her oath  
(Individual or **Managing Officer**)

deposes and states that he/she is the (applicant) (the managing officer of the corporation or partnership seeking the license hereunder), that he/she has read this application and fully understands same, that said license will be subject to all of the ordinances of the City pertaining to the operation of said business and agrees that he will abide by all lawful ordinances, regulations and rules adopted by the City relating to the conduct of said business, that he is in all respect qualified in law to receive such license, and that the answers and statements set out in the above application are true.

*Lorene Williams*  
Signature of Individual or **Managing Officer**

Subscribed and sworn to before me this 14th day of April, 2022

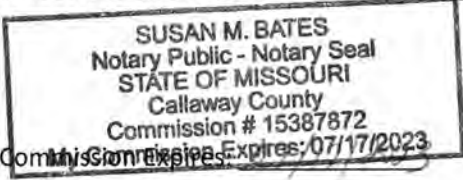

*Susan M. Bates*  
Notary Public

**NOTE: APPLICATION MUST BE SWORN TO BEFORE A NOTARY PUBLIC**

**SUPPLEMENT TO APPLICATION FOR LIQUOR LICENSE**

CORPORATION & LIMITED LIABILITY COMPANY:  
Copy of Certificate of Incorporation/ Registration &  
Articles of Organization papers must be attached

To the Florissant City Council,  
Florissant, St. Louis County, Missouri \_\_\_\_\_ DATE \_\_\_\_\_

**TO BE COMPLETED BY ALL PARTNERS, OR IF CORPORATION OR LIMITED  
LIABILITY CORPORATION BY ALL OFFICERS OR MEMBERS:**

1. FULL NAME See attached  
SOC. SEC. NO. \_\_\_\_\_ PLACE OF BIRTH \_\_\_\_\_  
DATE OF BIRTH \_\_\_\_\_ SEX \_\_\_\_\_  
PHONE NUMBER \_\_\_\_\_  
ADDRESS \_\_\_\_\_  
LAST PREVIOUS ADDRESS \_\_\_\_\_  
NO. OF YEARS \_\_\_\_\_

2. FULL NAME \_\_\_\_\_  
SOC. SEC. NO. \_\_\_\_\_ PLACE OF BIRTH \_\_\_\_\_  
DATE OF BIRTH \_\_\_\_\_ SEX \_\_\_\_\_  
PHONE NUMBER \_\_\_\_\_  
ADDRESS \_\_\_\_\_  
LAST PREVIOUS ADDRESS \_\_\_\_\_  
NO. OF YEARS \_\_\_\_\_

3. FULL NAME \_\_\_\_\_  
SOC. SEC. NO. \_\_\_\_\_ PLACE OF BIRTH \_\_\_\_\_  
DATE OF BIRTH \_\_\_\_\_ SEX \_\_\_\_\_  
PHONE NUMBER \_\_\_\_\_  
ADDRESS \_\_\_\_\_  
LAST PREVIOUS ADDRESS \_\_\_\_\_  
NO. OF YEARS \_\_\_\_\_

4. FULL NAME \_\_\_\_\_  
SOC. SEC. NO. \_\_\_\_\_ PLACE OF BIRTH \_\_\_\_\_  
DATE OF BIRTH \_\_\_\_\_ SEX \_\_\_\_\_  
PHONE NUMBER \_\_\_\_\_  
ADDRESS \_\_\_\_\_  
LAST PREVIOUS ADDRESS \_\_\_\_\_  
NO. OF YEARS \_\_\_\_\_

DoorDash Essentials LLC

SHAREHOLDER - MEMBER - OFFICER INFORMATION						
LAST NAME Xu		FIRST NAME Tony		MIDDLE INITIAL X.	DATE OF BIRTH 09/20/1984	PLACE OF BIRTH
SOCIAL SECURITY NUMBER [REDACTED]	SEX <input checked="" type="checkbox"/> M <input type="checkbox"/> F	POSITION* CEO			NUMBER OF SHARES OWNED/% MEMBERSHIP INTEREST 0	
ADDRESS 2876 Washington St.		CITY San Francisco		STATE & ZIP CODE CA 94115	TELEPHONE NUMBER 650-892-8725	
LAST NAME Yandell		FIRST NAME Keith		MIDDLE INITIAL D.	DATE OF BIRTH 04/15/1979	PLACE OF BIRTH
SOCIAL SECURITY NUMBER [REDACTED]	SEX <input checked="" type="checkbox"/> M <input type="checkbox"/> F	POSITION* Treasurer			NUMBER OF SHARES OWNED/% MEMBERSHIP INTEREST 0	
ADDRESS 1142 Glen Rd.		CITY Lafayette		STATE & ZIP CODE CA 94549	TELEPHONE NUMBER 925-708-7522	
LAST NAME Sherringham		FIRST NAME Tia		MIDDLE INITIAL A.	DATE OF BIRTH 1/21/82	PLACE OF BIRTH
SOCIAL SECURITY NUMBER [REDACTED]	SEX <input type="checkbox"/> M <input checked="" type="checkbox"/> F	POSITION* Secretary			NUMBER OF SHARES OWNED/% MEMBERSHIP INTEREST 0	
ADDRESS 72 Townsend Street, Unit 903		CITY San Francisco		STATE & ZIP CODE CA 94107	TELEPHONE NUMBER 917-854-0491	
LAST NAME DoorDash Essentials HoldCo, Inc.		FIRST NAME		MIDDLE INITIAL	DATE OF BIRTH	PLACE OF BIRTH
SOCIAL SECURITY NUMBER	SEX <input type="checkbox"/> M <input type="checkbox"/> F	POSITION*			NUMBER OF SHARES OWNED/% MEMBERSHIP INTEREST 100%	
ADDRESS		CITY		STATE & ZIP CODE	TELEPHONE NUMBER	
LAST NAME		FIRST NAME		MIDDLE INITIAL	DATE OF BIRTH	PLACE OF BIRTH
SOCIAL SECURITY NUMBER	SEX <input type="checkbox"/> M <input type="checkbox"/> F	POSITION*			NUMBER OF SHARES OWNED/% MEMBERSHIP INTEREST	
ADDRESS		CITY		STATE & ZIP CODE	TELEPHONE NUMBER	
LAST NAME		FIRST NAME		MIDDLE INITIAL	DATE OF BIRTH	PLACE OF BIRTH
SOCIAL SECURITY NUMBER	SEX <input type="checkbox"/> M <input type="checkbox"/> F	POSITION*			NUMBER OF SHARES OWNED/% MEMBERSHIP INTEREST	
ADDRESS		CITY		STATE & ZIP CODE	TELEPHONE NUMBER	
LAST NAME		FIRST NAME		MIDDLE INITIAL	DATE OF BIRTH	PLACE OF BIRTH
SOCIAL SECURITY NUMBER	SEX <input type="checkbox"/> M <input type="checkbox"/> F	POSITION*			NUMBER OF SHARES OWNED/% MEMBERSHIP INTEREST	
ADDRESS		CITY		STATE & ZIP CODE	TELEPHONE NUMBER	
LAST NAME		FIRST NAME		MIDDLE INITIAL	DATE OF BIRTH	PLACE OF BIRTH
SOCIAL SECURITY NUMBER	SEX <input type="checkbox"/> M <input type="checkbox"/> F	POSITION*			NUMBER OF SHARES OWNED/% MEMBERSHIP INTEREST	
ADDRESS		CITY		STATE & ZIP CODE	TELEPHONE NUMBER	

\*POSITION = PRESIDENT, VICE-PRESIDENT, EXECUTIVE VICE-PRESIDENT, SECRETARY, TREASURER, MEMBER, SHAREHOLDER, CHAIRMAN, TRUSTEE, CEO, DIRECTOR

**PLEASE FILL OUT THIS FORM AND RETURN WITH YOUR LICENSE APPLICATION**

In order for the Police Department to provide you with the best possible service, it is necessary for them to have certain information concerning your business:

**EMERGENCY INFORMATION**

OWNER OF PROPERTY \_\_\_\_\_ PHONE \_\_\_\_\_  
ADDRESS \_\_\_\_\_ CITY \_\_\_\_\_ STATE \_\_\_\_\_ ZIP \_\_\_\_\_

NAME OF BUSINESS \_\_\_\_\_ PHONE \_\_\_\_\_  
ADDRESS \_\_\_\_\_ CITY \_\_\_\_\_ STATE \_\_\_\_\_ ZIP \_\_\_\_\_

BUSINESS HOURS \_\_\_\_\_  
OWNER/MANAGER \_\_\_\_\_ PHONE \_\_\_\_\_  
HOME ADDRESS \_\_\_\_\_ CITY \_\_\_\_\_ STATE \_\_\_\_\_ ZIP \_\_\_\_\_

**PLEASE LIST PERSONS TO BE CONTACTED AFTER BUSINESS HOURS IN CASE OF AN EMERGENCY  
OR IF THERE IS A DOOR OR WINDOW FOUND INSECURE**

**CONTACT #1**

NAME \_\_\_\_\_ ADDRESS \_\_\_\_\_  
CITY & STATE \_\_\_\_\_ ZIP \_\_\_\_\_ PHONE \_\_\_\_\_  
HAS KEY: YES  NO ( )

**CONTACT #2**

NAME \_\_\_\_\_ ADDRESS \_\_\_\_\_  
CITY & STATE \_\_\_\_\_ ZIP \_\_\_\_\_ PHONE \_\_\_\_\_  
HAS KEY: YES  NO

ARE THERE LIGHTS LEFT ON AFTER BUSINESS HOURS: YES  NO

IS ANYONE AUTHORIZED TO BE ON THE PREMISES AFTER BUSINESS HOURS: YES  NO   
IF YES, WHO: \_\_\_\_\_

ARE ANY VEHICLES PARKED AT YOUR BUSINESS AFTER HOURS: YES ( ) NO

DESCRIBE: \_\_\_\_\_  
(YEAR) (MAKE/MODEL) (COLOR) (LICENSE NO.)

DO YOU HAVE A SAFE OF ANY KIND? YES ( ) NO ( )  
IF YES, WHERE IS IT LOCATED: \_\_\_\_\_

CAN IT BE SEEN FROM THE OUTSIDE? YES  NO   
IS YOUR BUSINESS PROTECTED WITH AN ALARM SYSTEM? YES  NO

**IF AT ANY TIME THERE IS A CHANGE IN THE ABOVE INFORMATION, PLEASE NOTIFY THE POLICE DEPARTMENT IMMEDIATELY, ESPECIALLY IN THE CASE OF THOSE PERSONS TO NOTIFY IN CASE OF AN EMERGENCY. THANK YOU.**

**APPLICATION FOR SUNDAY LIQUOR LICENSE**

To the City Clerk, City of Florissant, Saint Louis County Missouri

Authorizing the sale of retail liquor by the drink or package in the city of Florissant on **Sunday** from 9:00 a.m. to midnight

**TYPE OF OPERATION:**

( ) Individual      ( ) Partnership      ( ) Corporation       Limited Liability Corp

Name of Business DoorDash Essentials

Location 1 Paddock Hills Shopping Center, Unit 1D Phone \_\_\_\_\_

Exact Trade Name, LLC or Corporation DoorDash Essentials LLC

The undersigned (Individual, Partnership, Corporation, LLC ), hereby makes application to the City Clerk, City of Florissant, St. Louis County, Missouri for a "By the Drink/Package Liquor License" authorizing the sale of retail liquor on Sundays from 9:00 a.m. to midnight for the period beginning on \_\_\_\_\_ and expiring on June 30, 2017, on the above described premises and agrees that if the license herein applied for is granted, and the licensee shall violate any provisions of the State Liquor Control Act or of the City of Florissant Code and particularly any provision of Chapter 600 of the Florissant City Code pertaining to alcoholic beverages or permit any other person to do so upon the licensed premises, the City Council, by a majority vote, may suspend or revoke such license.

1) I/WE presently hold Florissant License Number \_\_\_\_\_ authorizing the sale of retail liquor by the drink or package in Florissant for premises described in this application.

STATE OF MISSOURI ) SS  
COUNTY OF ST. LOUIS )

I Lorene Williams of lawful age, being first duly sworn upon my oath, depose and say that I  
(Print Name of Managing Officer)

have read this application and that I fully understand the same; that I know the contents thereof and the statements contained therein and that the same are true of my own knowledge.

*Lorene Williams*  
Signature of Individual or Managing Officer

Subscribed and sworn to before me this 14th day of April, 2022.

*Susan M. Bates*  
Notary Public

My Commission Expires: 07/17/2023



# CITY OF FLORISSANT



FLORISSANT, MISSOURI

## WAIVER

Authorization to complete record check

I, Lorene Williams  
RESIDING AT 4827 Sunrise Drive  
IN THE CITY OF Jefferson City  
STATE MO

I do hereby authorize the City Clerk of the City of Florissant, Missouri to make a full and complete check of my record in the Metropolitan St. Louis area, state of Missouri, all prior areas of residence, and through the National Criminal Information Center in Washington, D.C.

*Susan R. Bates*  
Witness

*Lorene Williams*  
Signature

04/14/2022  
Date

01/15/77  
Date of Birth

[REDACTED]

[REDACTED]

\*\* Social Security Number

\*\* Driver's License Number & State

*\*\* Social Security & Driver's License Numbers will be used for purposes of identification in completing record check.*





## No Match Notification

A statewide search of the identifiers below has revealed no criminal conviction or sex offender information on file. Fingerprints were not provided and thus the result of the search cannot be guaranteed.

Date of Search: 04/19/2022

Name (1): LORENE WILLIAMS

Name (2):

Name (3):

Date Of Birth: 01/15/1977

SSN: xxx-xx-6190

Control Number: 5933602

If you have any questions, please do not hesitate to contact our office at 573-526-6153.

Missouri State Highway Patrol  
Criminal Justice Information Services Division  
PO BOX 9500  
Jefferson City, MO 65102



**State of Missouri**  
John R. Ashcroft, Secretary of State

Corporations Division  
PO Box 778 / 600 W. Main St., Rm. 322  
Jefferson City, MO 65102

**FL001431727**  
**Date Filed: 3/19/2020**  
**John R. Ashcroft**  
**Missouri Secretary of State**

**Application for Registration of a Foreign  
Limited Liability Company**

*(Submit with filing fee of \$105.00)*

- The name of the foreign limited liability company is: DOORDASH ESSENTIALS, LLC
  - The name under which the foreign limited liability company will conduct business in Missouri is (must contain "limited company", "limited liability company", "LC", "LLC", "L.C.", or "L.L.C.") (must be filled out if different from line (1)):  
  
\_\_\_\_\_
  - The foreign limited liability company was formed under the laws of DELAWARE on the date of 08/22/2019 (state or jurisdiction)  
(month/day/year)
  - The purpose of the foreign limited liability company or the general character of the business it proposes to transact in this state is:  
  
**OWN AND OPERATE CONVENIENCE WAREHOUSES**
  - The name and address of the limited liability company's registered agent in Missouri is (this line must be completed and include a street address):  
  
REGISTERED AGENT SOLUTIONS, INC. 3225-A EMERALD LANE JEFFERSON CITY, MO 65109  
Name Address (PO Box may only be used in conjunction with a physical street address) City/State/Zip
- The Secretary of State is appointed agent for service of process if the foreign limited liability company fails to maintain a registered agent. Note: failure to maintain a registered agent constitutes grounds to cancel the registration of the foreign limited liability company.*
- The address of the registered office in the jurisdiction organized. If none required, then the principal office address of the foreign limited liability company is:  
  
303 2nd Street, South Tower, 8th Floor SAN FRANCISCO, CA 94103  
Address (PO Box may only be used in conjunction with a physical street address) City/State/Zip
  - This application must include a current certificate of good standing/existence from the secretary of state or other similar official in the state of domicile. Such document should be dated within 60 calendar days from filing.

*(Please see next page)*

Name and address to return filed document:

Name: \_\_\_\_\_

Address: \_\_\_\_\_

City, State, and Zip Code: \_\_\_\_\_

ORI-03192020-0613 State of Missouri  
No of Pages 3 Pages

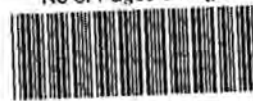

Creation - LLC/LP/LLP



8.  Series LLC (OPTIONAL) Pursuant to Section 347.186, the foreign limited liability company may establish a designated series in its operating agreement. The names of the series must include the full name of the limited liability company under which it has been admitted to transact business in this state and are the following:

New Series:

The limited liability company gives notice that the series has limited liability.

New Series:

The limited liability company gives notice that the series has limited liability.

New Series:

The limited liability company gives notice that the series has limited liability.

(Each separate series must also file an Attachment Form LLC 4A.)

In Affirmation thereof, the facts stated above are true and correct.

(The undersigned understands that false statements made in this filing are subject to the penalties provided under Section 575.040, RSMo)

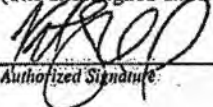
 Keith Vandell 3/11/2020  
*Authorized Signature* *Printed Name* *Date*

\_\_\_\_\_  
*Authorized Signature* *Printed Name* *Date*

\_\_\_\_\_  
*Authorized Signature* *Printed Name* *Date*

# Delaware

The First State

Page 1

I, JEFFREY W. BULLOCK, SECRETARY OF STATE OF THE STATE OF DELAWARE, DO HEREBY CERTIFY "DOORDASH ESSENTIALS, LLC" IS DULY FORMED UNDER THE LAWS OF THE STATE OF DELAWARE AND IS IN GOOD STANDING AND HAS A LEGAL EXISTENCE SO FAR AS THE RECORDS OF THIS OFFICE SHOW, AS OF THE NINTH DAY OF MARCH, A.D. 2020.

AND I DO HEREBY FURTHER CERTIFY THAT THE SAID "DOORDASH ESSENTIALS, LLC" WAS FORMED ON THE TWENTY-SECOND DAY OF AUGUST, A.D. 2019.

AND I DO HEREBY FURTHER CERTIFY THAT THE ANNUAL TAXES HAVE BEEN ASSESSED TO DATE.



7554800 8300

SR# 20202004111

You may verify this certificate online at [corp.delaware.gov/authver.shtml](http://corp.delaware.gov/authver.shtml)

A handwritten signature in black ink, appearing to read "JBULLOCK", is written over a horizontal line. Below the line, the text "Jeffrey W. Bullock, Secretary of State" is printed in a small font.

Authentication: 202543505

Date: 03-09-20

# STATE OF MISSOURI



**John R. Ashcroft**  
Secretary of State

## CERTIFICATE OF REGISTRATION

WHEREAS,

*DOORDASH ESSENTIALS, LLC*  
*FL001431727*

existing under the laws of the State of Delaware has filed with this state its Application of Registration and whereas this Application of Registration conforms to the Missouri Limited Liability Company Act.

NOW, THEREFORE, I, JOHN R. ASHCROFT, Secretary of State of the State of Missouri, by virtue of the authority vested in me by law, do hereby certify and declare that on the 19th day of March, 2020, the above Foreign Limited Liability Company is duly authorized to transact business in the State of Missouri and is entitled to any rights granted Limited Liability Companies.

IN TESTIMONY WHEREOF, I hereunto set my hand and cause to be affixed the GREAT SEAL of the State of Missouri. Done at the City of Jefferson, this 19th day of March, 2020.

  
Secretary of State



*Resolution no. 1041*

**RESOLUTION OF THE CITY OF FLORISSANT SUPPORTING A  
GRANT APPLICATION FOR A MUNICIPAL PARK GRANT ROUND  
23 FOR RELOCATION AND CONSTRUCTION OF NEW RESTROOM  
IN ST. FERDINAND PARK.**

WHEREAS, the City Council deems it necessary to improve a public park or facility, more specifically known as St. Ferdinand Park, to serve its citizens as well as those in the metropolitan area.

NOW, THEREFORE, BE IT RESOLVED BY THE CITY COUNCIL OF THE CITY OF FLORISSANT MISSOURI AS FOLLOWS:

1. An application be made to the Municipal Park Grant Program in the County of St. Louis for a grant-in-aid for some or all the costs of the project, reimbursable by the Commission upon completion by the city.
2. That a project proposal be prepared and submitted to the Municipal Park Grant Commission.
3. The governing body hereby authorizes Mayor Timothy J. Lowery to sign and execute the necessary documents for forwarding the project proposal application and later execute an agreement for a grant-in-aid from the Municipal Park Grant Commission.
4. If a grant is awarded, the City of Florissant will enter into an agreement or contract with the Commission regarding said grant.

PASSED AND RESOLVED THIS \_\_\_\_\_ DAY OF \_\_\_\_\_, 20\_\_.

Attest: \_\_\_\_\_  
Joseph Eagan, Council President

\_\_\_\_\_  
Karen Goodwin, MPPA/MMC/MRCC  
City Clerk

# FLORISSANT CITY COUNCIL

## AGENDA REQUEST FORM

Date: June 15, 2022 \_\_\_\_\_

**Mayor's Approval:**

Agenda Date Requested: | 27-Jun-22

Resolution in support of a Municipal Park Grant to relocation and build a new restroom in St. Ferdinand Park Riound 23.

Department: Parks and Recreation

Recommending Board or Commission:

Type of request:

Ordinances	X	Other	X
Appropriation		Liquor License	
Transfer		Hotel License	
Zoning Amendment		Special Presentations	
Amendment		Resolution	X
Special Use Transfer		Proclamation	
Special Use		Subdivision	
Budget Amendment	X		

Public Hearing needed: **Yes / No**

**NO**

3 readings? : **Yes / No**

**YES**

**Back up materials attached:**

**Back up materials needed:**

Minutes		Minutes	
Maps		Maps	
Memo		Memo	
Draft Ord.		Draft Ord.	

**Note:** Please include all attachments necessary for documents to be generated for inclusion on the Agenda. All agenda requests are to be turned in to the City Clerk by 5pm on Tuesday prior to the Council meeting.

For City Clerk Use Only:

Introduced by: \_\_\_\_\_

PH Speaker: \_\_\_\_\_

1 INTRODUCED BY COUNCILMAN SIAM  
2 JUNE 27, 2022

3  
4 BILL NO. 9793

ORDINANCE NO.

5

6 **ORDINANCE AUTHORIZING A TRANSFER OF SPECIAL USE**  
7 **PERMIT NO. 8603 FROM SHADE PARTNERS, LLC TO SHADE**  
8 **RESTAURANT & BAR, LLC FOR THE LOCATION OF A**  
9 **RESTAURANT AND BAR LOCATED AT 1752-1756 N. NEW**  
10 **FLORISSANT ROAD.**

11

12 WHEREAS, the Florissant Zoning Ordinance authorizes the Council of the City of  
13 Florissant, by Special Use Permit, after public hearing thereon, to permit the location of a  
14 restaurant; and

15 WHEREAS Five Aces Bar-v-que was issued Special Use Permit no. 8376 for the  
16 operation of a restaurant located at 1752-1754 N. New Florissant Road; and

17 WHEREAS ordinance no. 8376 was subsequently transferred by ordinance no. 8407 to  
18 CA44 LLC d/b/a Highway 67 BBQ for the operation of a restaurant; and

19 WHEREAS ordinance no. 8704 was transferred by ordinance no. 8603 to Shade Partners,  
20 LLC d/b/a Shade Restaurant and Bar; and

21 WHEREAS Shade Restaurant & Bar LLC has filed an application to transfer Special use  
22 Permit no. 8603 authorizing the location and operation of a restaurant located at 1752-1756 N.  
23 New Florissant Road to its name; and

24 WHEREAS, the City Council of the City of Florissant determined at its meeting on June  
25 27, 2022 that the business would be operated in substantially identical fashion as set out herein;  
26 and

27 WHEREAS, Shade Restaurant and Bar, LLC has accepted the terms and conditions as  
28 they apply to a special use permit for a restaurant.

29 **NOW, THEREFORE, BE IT ORDAINED BY THE COUNCIL OF THE CITY OF**  
30 **FLORISSANT, ST. LOUIS COUNTY, MISSOURI, AS FOLLOWS:**

31 Section 1: Special Use Permit no. 8603 is hereby transferred from Shade Partners, LLC  
32 to Shade Restaurant & Bar, LLC for the location of a restaurant and bar located at 1752-1756  
33 N. New Florissant Road subject to the following conditions:

- 34 a. Full compliance with any and all conditions set forth in Special Use Permit
- 35 8603; and
- 36 b. There shall be no tinting of the windows or obstruction preventing clear sight
- 37 into the business from the parking lot or sidewalk; and
- 38 c. A security camera shall be installed to record activities indoor and outdoor, and
- 39 the video footage shall be available to the police department within 24 hours of
- 40 the request and shall be retained for a minimum of 10 days; and
- 41 d. The business shall be closed no later than 10 pm.

42 Section 2: The Special Use Permit herein authorized shall terminate if the said business  
 43 ceases operation for a period of more than one hundred and eighty (180) days.

44 Section 3. The Special Use Permit authorized herein will be revoked if the applicant fails  
 45 to comply with the conditions set forth herein or violates any State Statutes or ordinances of the  
 46 City of Florissant.

47 Section 4: This ordinance shall become in force and effect immediately upon its passage  
 48 and approval.

49 .

50 Adopted this \_\_\_\_ day of \_\_\_\_\_, 2022.

51 \_\_\_\_\_  
 52 Joseph Eagan  
 53 Council President

55 Approved this \_\_\_\_ day of \_\_\_\_\_, 2022.

56 \_\_\_\_\_  
 57 Timothy J. Lowery  
 58 Mayor, City of Florissant

59 ATTEST:  
 60 \_\_\_\_\_  
 61 Karen Goodwin, MPPA/MMC/MRCC  
 62 City Clerk

1 INTRODUCED BY COUNCILMAN SIAM  
2 FEBRUARY 24, 2020

3  
4 BILL NO. 9587

ORDINANCE NO.

**8603**

5  
6 **ORDINANCE AUTHORIZING A TRANSFER OF SPECIAL USE**  
7 **PERMIT NO. 8407 FROM HWY 67 BBQ TO SHADE PARTNERS, LLC**  
8 **D/B/A SHADE RESTAURANT AND BAR FOR THE PROPERTY**  
9 **LOCATED AT 1752-1754 N. NEW FLORISSANT ROAD.**

10  
11 WHEREAS, the Florissant Zoning Ordinance authorizes the Council of the City of  
12 Florissant, by Special Use Permit, after public hearing thereon, to permit the location of a  
13 restaurant; and

14 WHEREAS, 5 Aces BBQ was granted Special Use Permit no. 8376 for the location of a  
15 restaurant located at 1752-54 N. New Florissant Road, and

16 WHEREAS Special Use Permit no. 8376 was transferred to CA44 d/b/a Hwy 67 BBQ by  
17 Ordinance no. 8407; and

18 WHEREAS, an application has been filed by Shade Partners LLC to transfer the Special  
19 Use Permit authorized by Ordinance No. 8407 to its name; and

20 WHEREAS, the City Council of the City of Florissant determined at its meeting on  
21 February 10, 2020 that the business would be operated in substantially identical fashion as set  
22 out herein; and

23 WHEREAS, Shade Partners, LLC has accepted the terms and conditions set out in  
24 Ordinance No. 8407 as transferred from Ordinance no. 8376.

25  
26 NOW, THEREFORE, BE IT ORDAINED BY THE COUNCIL OF THE CITY OF  
27 FLORISSANT, ST. LOUIS COUNTY, MISSOURI, AS FOLLOWS:

28  
29  
30 Section 1: The Special Use Permit authorized by Ordinance No. 8407 is hereby  
31 transferred Hwy 67 BBQ to Shade Partners, LLC d/b/a Shade Restaurant and bar for the property  
32 located at 1752-1754 N. New Florissant Road.

33 Section 2: The terms and conditions of said Special Permit authorized by Ordinance No.  
34 8407 as transferred from Ordinance no. 8376 shall remain in full force and effect.

35 Section 3: The Special Use Permit herein authorized shall terminate if the said business  
36 ceases operation for a period of more than ninety (90) days.

37 Section 4: This ordinance shall become in force and effect immediately upon its passage  
38 and approval.



39  
40  
41  
42  
43  
44  
45  
46  
47  
48  
49  
50  
51  
52  
53  
54  
55  
56  
57  
58  
59  
60

Adopted this 9 day of March, 2020.

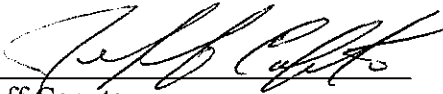
  
Jeff Caputa  
Council President

Approved this 9 day of March, 2020.

  
Timothy J. Lowery  
Mayor, City of Florissant

ATTEST:

  
Karen Goodwin, MPPA/MMC/MRCC  
City Clerk



# City of Florissant

*Honorable Timothy J. Lowery, Mayor*

## **TRANSFER OF SPECIAL USE PERMIT PROCEDURE**

After receiving completed Transfer of Special Use Permit application, the City Clerk places the Transfer request on the next City Council Agenda for acceptance of the application and 1<sup>st</sup> reading of the new bill.

Applicant is encouraged to contact the Councilperson of the ward prior to the City Council Meeting.

At the following meeting the bill is read for a second and third time and voted upon. With a majority of affirmative votes the bill is assigned an Ordinance number.

**The application for a Transfer of a Special Use requires the following for a complete application:**

1. Completed application form  
(with the signature from current owner to authorize the transfer of the ordinance in their name)
2. Complete acknowledgement form  
(Acknowledging that the new owner has received a copy of the current ordinance and accepts responsibility for the Special Use Permit as it is written)
3. Copy of the LLC or Corporation papers.
4. Copy of a lease or bill of sale (to show an interest in the property)
5. Copy of the Fictitious name certificate (if applicable)

**Return completed application and documentation to the City Clerk's office no later than 5 pm on Wednesday prior to a scheduled City Council meeting (2<sup>nd</sup> and 4<sup>th</sup> Mondays of each month)**

Questions: Call the City Clerk at 314-839-7630 or 7631 or email [kgoodwin@florissantmo.com](mailto:kgoodwin@florissantmo.com)

**TRANSFER OF SPECIAL PERMIT**

AUTHORIZED BY ORDINANCE NUMBER (S) 8603

FROM Shade Parteners, LLC  
TO Shade Restaurant & Bar , LLC  
FOR A restaurant & bar  
ADDRESS 1752-1756 N. New Florissant, Florissant, MO 63033  
Ward 6 Zoning B3 Date Filed 6/8/2022 Accepted By \_\_\_\_\_

**TRANSFER OF SPECIAL USE PERMIT PETITION**

TO THE CITY COUNCIL OF THE CITY OF FLORISSANT:

1. Comes now Shade Restaurant & Bar, LLC and states to the City Council that he (she) (they) has (have) the following legal interest in the property located at 1752-1756 N. New Florissant, Florissant, MO 63034 in the City of Florissant, Missouri. Legal interest:  Lease or  Simple Title  
(Attach signed copy of lease or deed)
2. The petitioner(s) further state that he (she) (they) has (have) not made any arrangement to pay any commission, gratuity, or consideration, directly or indirectly to any official, employee, or appointee of the City of Florissant, with respect to this petition.
3. The applicant will operate the business in the same manner and under the same conditions as set out in the original ordinance granting the special permit or any amendments thereto, except for any proposed change in sign face of an authorized sign.

PETITIONER SIGNATURE

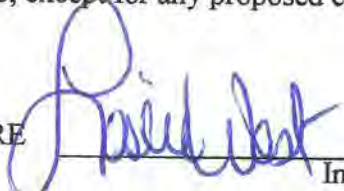

Individual's Name

FOR:

Shade Restaurant & Bar, LLC

Company, Corporation, Partnership

4. I (we) hereby certify that (indicate **one only**):

- I (we) have a legal interest in the above described property.  
 I am (we are) the duly appointed agent (s) of the petitioner, and that all information given is true and a statement of fact.

SIGNATURE \_\_\_\_\_

ADDRESS 38 Jost Villa Dr. Florissant, MO 63034

Telephone No. 314-780-4890 Email address Info@Shaderesturant.com

I (we) the petitioner(s) do hereby appoint Lisa West as my (our) duly authorized agent to represent me (us) in regard to this petition.



\_\_\_\_\_  
PETITIONER SIGNATURE

**Note:** Petitioner or his/her authorized agent will be the only person(s) permitted to make the presentation to the City Council.

5. Acknowledgement and consent of (**current**) owner to Transfer the Special Use Permit.



\_\_\_\_\_  
SIGNATURE OF OWNER

**Information sheet to be attached to all requests for Transfer of Special Permit**

Type of Operation: (Select One)

Individual       Partnership       Corporation       LLC

**INDIVIDUAL:**

Name & address \_\_\_\_\_

Telephone number & email address \_\_\_\_\_

Business name/address/phone \_\_\_\_\_

Copy of fictitious name registration, if applicable \_\_\_\_\_

**PARTNERSHIP:**

Name & address of partner (s) \_\_\_\_\_

Telephone number(s) and email address (s) \_\_\_\_\_

Business name/ address /phone \_\_\_\_\_

Copy of fictitious name registration, if applicable \_\_\_\_\_

**CORPORATION OR LLC:**

Name & address of all corporate officers Leslie West

Telephone numbers & email addresses 314-780-4890 Info@shaderesturant.com

Business name/address/phone Shade Resturant & Bar, LLC

Photocopy of Corporation/LLC Articles and Certificate \_\_\_\_\_

Date of incorporation/LLC 6/2/2022

Copy of fictitious name registration, if applicable

Copy of latest Missouri Anti-Trust affidavit (annual registration of corporate officers)



**TRANSFER OF SPECIAL USE PERMIT**

The undersigned hereby acknowledges receipt of a copy of Ordinance  
Number 8603 which previously authorized a Special Use Permit:

TO: Shade Restuarant & Bar, LLC

FOR: A restaurant and bar

Located at: 1752-1756N.New Florissant, Florissant MO 63033

and agree to the terms and conditions listed in said ordinance and to any  
additional term and conditions that the City Council shall deem appropriate.

Leslie West

PRINT - NAME OF APPLICANT

  
\_\_\_\_\_

SIGNATURE OF APPLICANT



**State of Missouri**  
**John R. Ashcroft, Secretary of State**  
 Corporations Division  
 PO Box 778 / 600 W. Main St., Rm. 322  
 Jefferson City, MO 65102

**LC014383013**  
**Date Filed: 6/2/2022**  
**John R. Ashcroft**  
**Missouri Secretary of State**

**Articles of Organization**

*(Submit with filing fee of \$105.00)*

1. The name of the limited liability company is  
Shade Restaurant & Bar LLC

*(Must include "Limited Liability Company," "Limited Company," "LC," "L.C.," "LLC," or "LLC")*

2. The purpose(s) for which the limited liability company is organized:

To operate a restaurant and bar as well as provide event space.

3. The name and address of the limited liability company's registered agent in Missouri is:

Aaron Lamont Reeves

<u>Jr</u>	<u>5920 Ridge Ave</u>	<u>Saint Louis, MO 63112-3510</u>
<i>Name</i>	<i>Street Address: May not use PO Box unless street address also provided</i>	<i>City/State/Zip</i>

4. The management of the limited liability company is vested in:     managers     members    *(check one)*

5. The events, if any, on which the limited liability company is to dissolve or the number of years the limited liability company is to continue, which may be any number or perpetual: 6/2/2097

*(The answer to this question could cause possible tax consequences, you may wish to consult with your attorney or accountant)*

6. The name(s) and street address(es) of each organizer *(PO box may only be used in addition to a physical street address):*

*(Organizer(s) are not required to be member(s), manager(s) or owner(s))*

<i>Name</i>	<i>Address</i>	<i>City/State/Zip</i>
<u>WEST, LESLIE</u>	<u>38 Jost Villa Dr</u>	<u>Florissant MO 63034-2270</u>

7.  Series LLC (OPTIONAL) Pursuant to Section 347.186, the limited liability company may establish a designated series in its operating agreement. The names of the series must include the full name of the limited liability company and are the following:

New Series:

The limited liability company gives notice that the series has limited liability.

New Series:

The limited liability company gives notice that the series has limited liability.

New Series:

The limited liability company gives notice that the series has limited liability.

*(Each separate series must also file an Attachment Form LLC 1A.)*

Name and address to return filed document:

Name: Aaron Lamont Reeves

Address: Email: aaronr1672@sbcglobal.net

City, State, and Zip Code: \_\_\_\_\_

# STATE OF MISSOURI



**John R. Ashcroft**  
**Secretary of State**

## CERTIFICATE OF ORGANIZATION

WHEREAS,

*Shade Restaurant & Bar LLC*  
*LC014383013*

filed its Articles of Organization with this office on the 2nd day of June, 2022, and that filing was found to conform to the Missouri Limited Liability Company Act.

NOW, THEREFORE, I, John R. Ashcroft, Secretary of State of the State of Missouri, do by virtue of the authority vested in me by law, do certify and declare that on the 2nd day of June, 2022, the above entity is a Limited Liability Company, organized in this state and entitled to any rights granted to Limited Liability Companies.

IN TESTIMONY WHEREOF, I hereunto set my hand and cause to be affixed the GREAT SEAL of the State of Missouri.  
Done at the City of Jefferson, this 2nd day of June, 2022.

  
Secretary of State

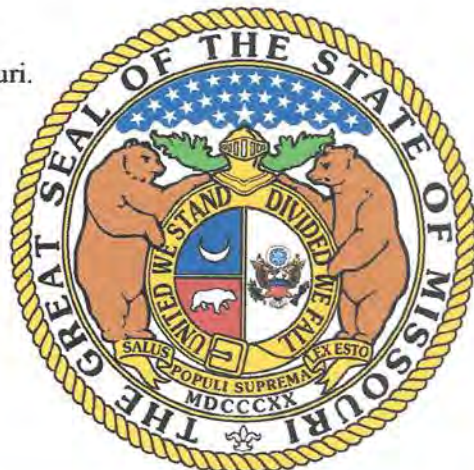



## ASSIGNMENT OF LEASE

This Assignment is entered on this \_\_\_\_\_ day of June, 2022 by and between Bella Marie Agency, L.L.C., a Missouri Limited Liability Company (referred to herein as "Assignor"), and Shade Restaurant & Bar, L.L.C., a Missouri Limited Liability Company (referred to herein as "Assignee") and LCRF, L.L.C., a Missouri Limited Liability Company, (hereinafter referred to as "Landlord").

### WHEREAS:

Assignor is the tenant under a certain written lease agreement dated January 17, 2022, for certain premises located at 1752, 1754 & 1756 New Florissant Road, Florissant, Missouri 63033 (the "Leased Premises"), the term of which is currently ending on December 31, 2025, (the "Lease").

### WHEREAS:

LCRF, L.L.C., a Missouri Limited Liability Company is the owner of the Leased premises and the Landlord of the Leased Premises under the said Lease, and

### WHEREAS:

Assignor desires to sell and assign all of its right, title and interest in all of the lease described above with the written consent of the Landlord;

### NOW THEREFORE:

In consideration of the premises, and of the assignments made, and of the mutual covenants and agreements set forth herein, the parties to this Assignment agree as follows:

1. Assignor assigns any and all of the right, title and interest of the Lease of the premises known as Flo-Lin I Shopping Center located at 1752, 1754 & 1756 New Florissant Road, Florissant, Missouri 63033 to Assignee effective on May 15, 2022, and Landlord expressly consents to the Assignment on the terms and conditions set forth herein.

2. In order to induce Landlord to consent to this Assignment, Assignor agrees to remain liable to said Landlord for the obligation to pay all rent through the date of this Assignment and for all other debts or obligations, including CAM, Tax and Insurance as well as 2022 year end reconciliation, through the effective date of this Assignment.

3. Except for those debts or obligations specifically noted in Paragraph 2 above, Assignor is released from all liability for the performance of all duties and obligations under the terms and conditions of the Lease described herein and/or under any oral or written modification to such Lease, which were not performed by Assignor prior to the effective date of this Assignment.

4. Assignee shall have no obligation or liability whatsoever for any debt or obligation which Assignor owes to the Landlord or to any predecessor at the time of this Assignment including, but not limited to, rent or other debts or obligations arising out of the Assignors' use and occupation of the premises prior to the effective date of this Assignment.

5. The laws of the State of Missouri shall govern this Assignment of Lease.

6. Assignor's forwarding address shall be 38 Jost Villa Drive, Florissant, MO 63033

7. Assignee's forwarding address shall be 38 Jost Villa Drive, Florissant, MO 63033

**EXHIBIT A  
ASSIGNEE INFORMATION**

**INDIVIDUAL**

A. Name: Joseph West  
 Home Phone: 314-980-4890  
 Home Address: 3805+Village Dr  
 \_\_\_\_\_  
 How long at this address? 12  
 Mortgage Co: First Comm Credit  
 Address: 8917 N. Lindbergh Blvd (6303)  
 Phone #: 636-728-3333

Date of Birth: 1-27-81  
 Social Security: \_\_\_\_\_  
 Driver's License: DD2985029  
 Own: \_\_\_\_\_ Rent: \_\_\_\_\_  
 Landlord: Jenet Davis  
 Address: 1274 Woodpark Dr. Alexandria MO 63224  
 Phone #: 314-921-6714

B. Previous Address: \_\_\_\_\_  
 (less than 2 yrs.): \_\_\_\_\_

How long at this address? \_\_\_\_\_  
 Own: \_\_\_\_\_ Rent: \_\_\_\_\_

C. Employer Name: \_\_\_\_\_  
 Address: \_\_\_\_\_  
 \_\_\_\_\_

Phone #: \_\_\_\_\_  
 How long? \_\_\_\_\_  
 Contact? \_\_\_\_\_ Yes \_\_\_\_\_ No \_\_\_\_\_

D. Bus. Name: \_\_\_\_\_  
 Bus. Type: \_\_\_\_\_  
 Address: \_\_\_\_\_  
 \_\_\_\_\_

Phone #: \_\_\_\_\_  
 How long in business? \_\_\_\_\_  
 How long at this address? \_\_\_\_\_  
 Own: \_\_\_\_\_ Rent: \_\_\_\_\_

**CORPORATION**

**(Attach copy of most recent audited financial statement)**

A. Corp. Name: \_\_\_\_\_  
 Bus. Type: \_\_\_\_\_  
 Address: \_\_\_\_\_  
 \_\_\_\_\_  
 Mortgage Co: \_\_\_\_\_  
 Address: \_\_\_\_\_  
 Phone #: \_\_\_\_\_

Phone #: \_\_\_\_\_  
 How long in business? \_\_\_\_\_  
 How long at this address? \_\_\_\_\_  
 Own: \_\_\_\_\_ Rent: \_\_\_\_\_  
 Landlord: \_\_\_\_\_  
 Address: \_\_\_\_\_  
 Phone #: \_\_\_\_\_

B. Corporation Officers:

Name: \_\_\_\_\_  
 Address: \_\_\_\_\_  
 \_\_\_\_\_

Social Security #: \_\_\_\_\_  
 Title: \_\_\_\_\_  
 Home Phone #: \_\_\_\_\_

Name: \_\_\_\_\_  
 Address: \_\_\_\_\_  
 \_\_\_\_\_

Social Security #: \_\_\_\_\_  
 Title: \_\_\_\_\_  
 Home Phone #: \_\_\_\_\_

**Address**

**REFERENCES**

A. Credit References:

Name of Reference \_\_\_\_\_

\_\_\_\_\_

\_\_\_\_\_

Acct. # and Type

This Assignment consisting of three (3) pages including the page on which these signatures appear, and Exhibit A attached hereto, entered into the \_\_\_\_\_ day of June, 2022.

"ASSIGNOR"

**BELLA MARIE AGENCY, LLC  
A MISSOURI LIMITED LIABILITY  
COMPANY**

By:   
Leslie West

Title: owner

Date: 6-1-2022

"ASSIGNEE"

**SHADE RESTAURANT & BAR, LLC  
A MISSOURI LIMITED LIABILITY  
COMPANY**

By:   
Leslie West

Title: owner

Date: 6-1-2022

"LANDLORD"

**LCRF, L.L.C.,  
A MISSOURI LIMITED LIABILITY COMPANY**

By: LCRF Holdings, Inc., its managing members

By: \_\_\_\_\_  
Robert A. Walpert, President

Date: \_\_\_\_\_

1 INTRODUCED BY COUNCILMAN HENKE  
2 NOVEMBER 27, 2017

3  
4

5 BILL NO. 9334

ORDINANCE NO.

8376

6  
7  
8  
9  
10  
11

**ORDINANCE TO AUTHORIZE A SPECIAL USE PERMIT TO FIVE ACES  
BAR-B-QUE, LLC D/B/A FIVE ACES BAR-B-QUE TO ALLOW FOR THE  
OPERATION OF A RESTAURANT LOCATED AT 1752-1754 N. NEW  
FLORISSANT RD.**

12 WHEREAS, the Florissant Zoning Ordinance authorizes the City Council of the City of  
13 Florissant, by Special Use Permit, after public hearing thereon, to permit the location of a restaurant; and

14 WHEREAS, an application has been filed by Five Aces Bar-B-Que for the property located at  
15 1752-1754 N. New Florissant Rd for the location and operation of a restaurant; and

16 WHEREAS, the Planning and Zoning Commission of the City of Florissant, at their meeting of  
17 November 6<sup>th</sup>, 2017 has recommended that the said Special Use Permit be granted; and

18 WHEREAS, due notice of a public hearing no. 17-11-028 said application to be held on the 27<sup>th</sup>  
19 day of November, 2017 at 7:30 P.M. by the Council of the City of Florissant was duly published, held  
20 and concluded; and

21 WHEREAS, the Council, following said public hearing, and after due and careful consideration,  
22 has concluded that the granting of the Special Use Permit as hereinafter provided would be in the best  
23 interest of the City of Florissant.

24 NOW, THEREFORE, BE IT ORDAINED BY THE COUNCIL OF THE CITY OF  
25 FLORISSANT, ST. LOUIS COUNTY, MISSOURI, AS FOLLOWS:

26  
27

Section I: A Special Use Permit is hereby granted to Five Aces Bar-B-Que, LLC d/b/a Five Aces  
28 Bar-B-Que to allow for the operation of a restaurant located at 1752-1754 N. New Florissant Rd for the  
29 location and operation of a restaurant with carry-out service and the following additional requirements:

30

- 31 1) Relocate smoker behind the south building.
- 32 2) Provide roof cover protection and screening of new smoker, as approved by the Building  
33 Commissioner.
- 34 3) Smoker enclosure colors to be complimentary in color to the existing structure, as approved by  
35 the Building Commissioner.

36

37  
38  
39  
40  
41  
42  
43  
44  
45  
46  
47  
48  
49  
50  
51  
52  
53  
54  
55  
56  
57  
58  
59  
60  
61  
62  
63  
64  
65  
66  
67  
68

**2. PROJECT COMPLETION.**

Construction shall start within 30 days of the issuance of building permits and the structure shall be completed in accordance with the plans within 180 days of start of construction.

Section 2: When the named permittee discontinues the operation of said business, the Special Use Permit herein granted shall no longer be in force and effect.

Section 3: This ordinance shall become in force and effect immediately upon its passage and approval.

Adopted this 11 day of Dec, 2017.

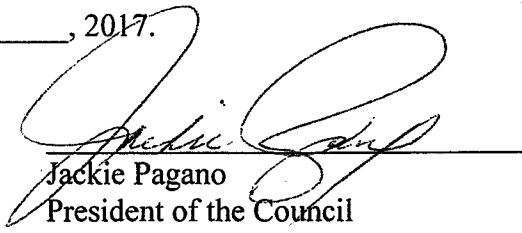
  
Jackie Pagano  
President of the Council  
City of Florissant

Approved this 12 day of DEC, 2017.

  
Thomas P. Schneider  
Mayor, City of Florissant

ATTEST:

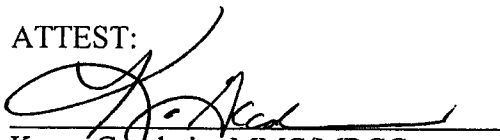
  
Karen Godwin, MMC/MRCC  
City Clerk

# FACILITY UPDATES FOR RESTAURANT RENOVATION

1752-1754 NORTH NEW FLORISSANT ROAD  
FLORISSANT, MISSOURI 63033

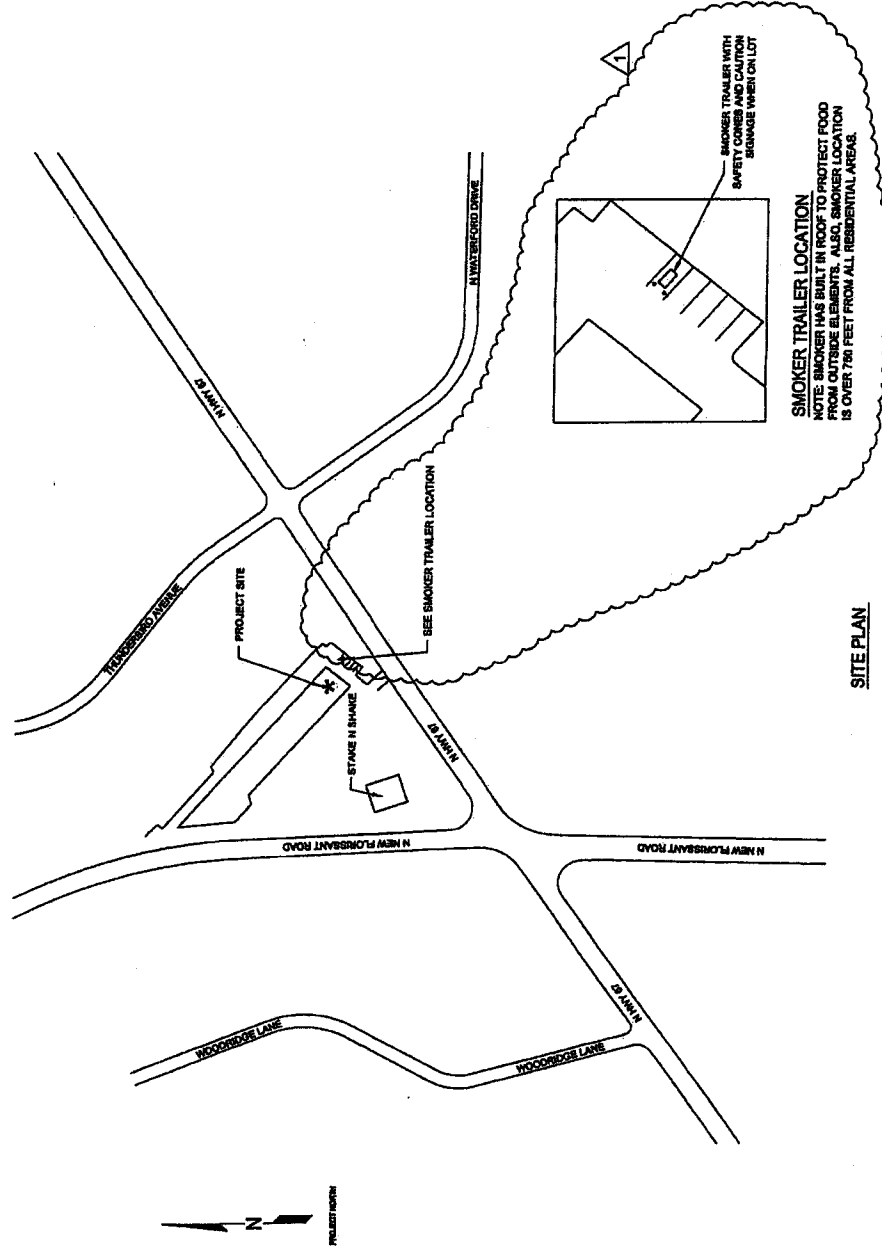

**SHEET INDEX:**

- A-0 SITE PLAN AND SCOPE
- A-1 EXISTING/DEMOLITION PLAN
- A-2 PROPOSED PLAN
- A-3 ENLARGED PROPOSED FLOOR PLAN
- A-4 SPECIAL DETAILS
- A-5 METAL STUD WALL DETAILS
- A-6 METAL STUD WALL DETAILS

**SCOPE OF WORK:**

1. PROJECT RENOVATION REQUIRE TO MODIFY AN EXISTING RESTROOM TO AN ADA RESTROOM, PROVIDE A KITCHEN (PREP AREA, HOT SINK AREA, COMMON WALL FIRE RATING INFORMATION, AND ADDITIONAL EMERGENCY RECOMMENDATION) AND FINISH. ALL DESIGN IS GOVERNED TO CURRENT CONSTRUCTION BUILDING CODES.
2. ALL PLUMBING AND ELECTRICAL WORK AND PERMITS SHALL BE OBTAINED BY OWNER'S PLUMBING AND ELECTRICAL CONTRACTORS.
3. OWNER IS RESPONSIBLE FOR PROVIDING ALL SAFETY CONER SIGNS AND SAFETY PRECAUTION THAT WOULD ENSURE VISIBILITY AND SAFETY RELATES TO THEIR SMOKER TRAILER WHEN IT IS BROUGHT TO USE LOCATION FOR USE.

*Allen Designs, LLC*  
10/26/17

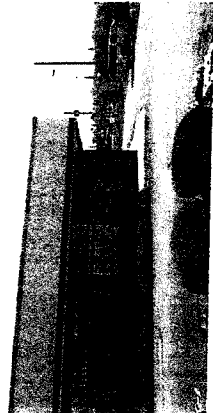

**ALLEN DESIGNS, LLC**

WWW.ALLENDIGNS.COM  
P.O. BOX 728, 85 N.W. 10th Ave, Suite 100  
TEL: 314-423-1827

**DOWND W. DEAL, P.E.**

MEMBER ARCHITECT  
ST. LOUIS, MO 63103  
PHONE: 314-313-0287  
LICENSE NO.: 22373

OWNER: \_\_\_\_\_  
DESIGNED BY: \_\_\_\_\_  
CHECKED BY: \_\_\_\_\_  
SCALE: \_\_\_\_\_  
DATE: \_\_\_\_\_  
JOB NO.: \_\_\_\_\_

**SITE PLAN AND SCOPE  
RESTAURANT RENOVATION  
1752-1754 N. NEW FLORISSANT RD  
FLORISSANT, MISSOURI 63033**

PROJECT NO. **2017-112**  
DRAWING NO. **A-0**

NO.	DATE	DESCRIPTION
1	10/26/17	ISSUED FOR PERMIT
2	10/26/17	ISSUED FOR PERMIT
3		
4		
5		



# ALLEN DESIGNS, LLC

PROJECTS AT: 1752-1754 N. NEW FLORISSANT RD. FLOISSANT, MISSOURI 63033  
 TEL: 314-823-9007  
 WWW.ALLENDISIGNS.COM

DESIGNED BY: DONALD W. DEAL, P.E.  
 CHECKED BY: JAS. BROWN  
 SCALE: AS SHOWN  
 DATE: 08/11/17  
 LICENSE NO.: 22077  
 EXPIRES: 08/31/18  
 1752-1754 N. NEW FLORISSANT RD. FLOISSANT, MISSOURI 63033

PROPOSED FLOOR PLAN  
 RESTAURANT RENOVATION  
 1752-1754 N. NEW FLORISSANT RD.  
 FLOISSANT, MISSOURI 63033

PROJECT NO.: 2017-112  
 DRAWING NO.: A-2

### GENERAL NOTES:

- CONSTRUCTION PER ALL GOVERNING CODES PER 2009 INTERNATIONAL BUILDING CODES.
- CONTRACTOR SHALL FIELD VERIFY ALL EXISTING CONDITIONS AND DIMENSIONS PRIOR TO CONSTRUCTION.
- ALL EXISTING REPAIR TO INTERIOR WALLS SHALL BE REPLACED WITH X-TYPE GYPSUM BOARD.
- ALL NEW PARTITION WALLS SHALL BE METAL STUD WALLS FOR TYPICAL METAL STUD DETAILS, SEE DRAWING A-2 UNLESS NOTED OTHERWISE.

### KEYED NOTES:

- PROVIDING SEPARATION WALL IS VERIFIED TO BE DOUBLE LAYER 5/8" GYPSUM BOARD, AND A REPAIR IS NOTED CALLING ALONG THE TOP ALONG CEILING DESIGN, SEE DETAIL JOINING THE GYPSUM BOARD, SEE DRAWING A-1 FOR SPECIAL DETAIL.
- ADD PANIC BAR WITH ALARM TO SIDE DOOR. PANIC BAR ALARM SHALL READ "EMERGENCY EXIT ONLY - ALARM WILL SOUND".
- NEW EXIT SIGNS WITH EMERGENCY LIGHTS (TYP.).
- PROPOSED BAR. BAR SUPPLIED BY OWNER.
- FINAL ORIENTATION OF APPLIANCES AND SINK ARE DETERMINED BY OWNER OR OWNER'S REPRESENTATIVE. NECESSARY RECEPTACLES FOR EACH APPLIANCE SHALL BE SUPPLIED BY QUALIFIED ELECTRICAL CONTRACTOR.
- FLOOR-SET MOP SINK. SEE DRAWING A-4 FOR DETAIL.

### LEGEND (ALL SYMBOLS MAY NOT BE USED):

- SMOKE DETECTOR - HARD WIRED WITH BATTERY BACKUP
- GROUND FAULT INDICATOR OUTLET
- RECEPTACLE OUTLET
- TRIPLE OUTLET
- PROPOSED LIGHT
- PROPOSED LIGHT/EXHAUST FAN
- NEW FLOOD LIGHT
- NEW WALL LIGHT
- NEW SWITCH
- NEW 3-WAY SWITCH
- EXIT SIGN
- EXIT SIGN WITH EMERGENCY LIGHTS

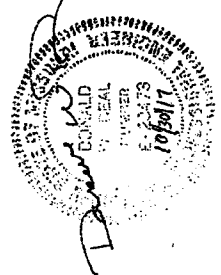
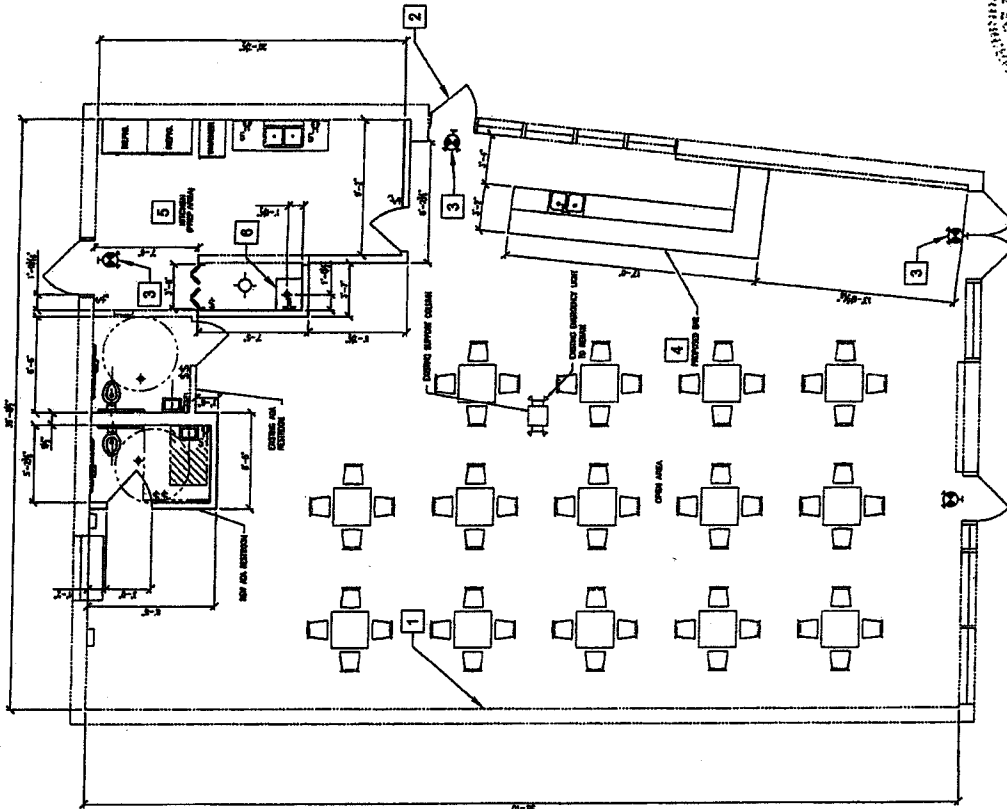

PROPOSED FLOOR PLAN  
 SCALE: 1/8" = 1'-0"

NO.	DATE	DESCRIPTION	BY	CHKD.
1	08/11/17	ISSUED FOR PERMIT-ADDED MECHANICAL		
0		ISSUED FOR PERMIT		

# FACILITY UPDATES FOR RESTAURANT RENOVATION

1752-1754 NORTH NEW FLORISSANT ROAD  
FLORISSANT, MISSOURI 63033

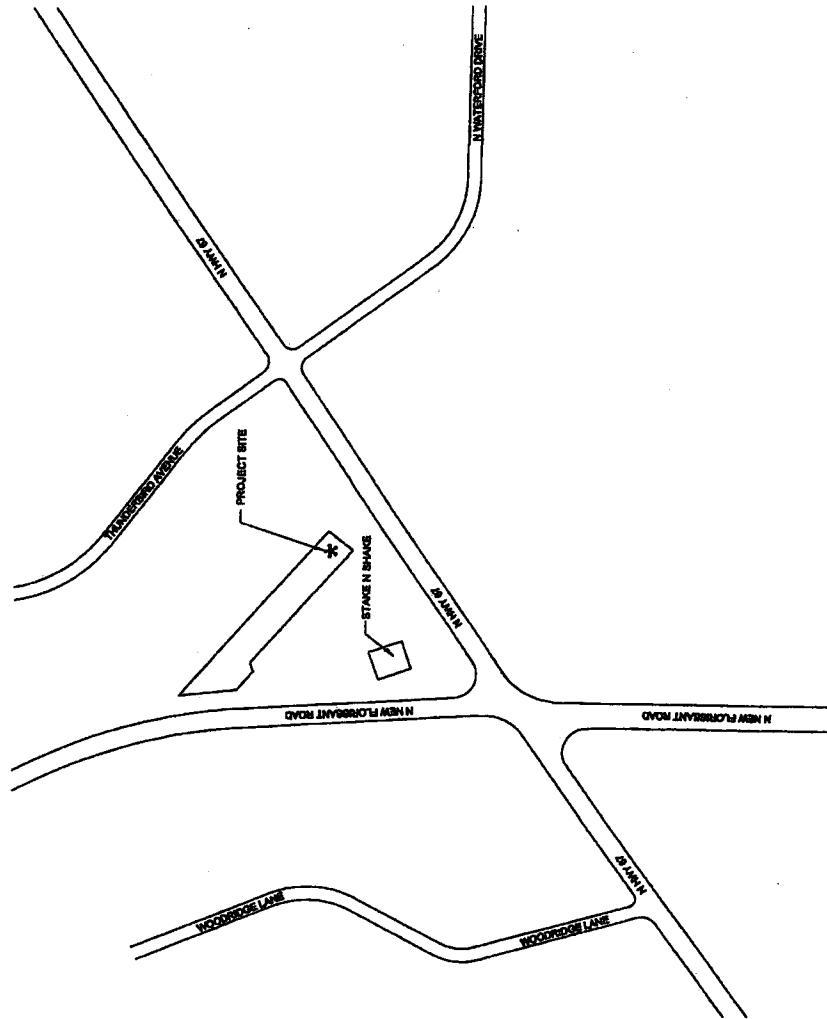

SITE PLAN

**SHEET INDEX:**

- A-0 SITE PLAN AND SCOPE
- A-1 EXISTING/DEMOLITION PLAN
- A-2 PROPOSED PLAN
- A-3 ENLARGED PROPOSED FLOOR PLAN
- A-4 SPECIAL DETAILS
- A-5 METAL STUD WALL DETAILS
- A-6 METAL STUD WALL DETAILS

**SCOPE OF WORK:**

1. PROJECT RENOVATION REQUIRE TO MODIFY AN EXISTING RESTROOM TO AN ADA RESTROOM, PROVIDE A KITCHEN (PREP AREA), AND PROVIDE A COMMON WALL FIRE RATING INFORMATION AND ALSO PROVIDE ALL DESIGN IS GOVERNED TO CURRENT CONSTRUCTION BUILDING CODES.
2. ALL PLUMBING AND ELECTRICAL WORK AND PERMITS SHALL BE OBTAINED BY OWNER'S PLUMBING AND ELECTRICAL CONTRACTORS.

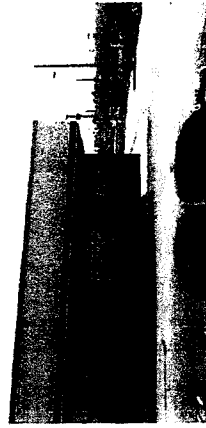
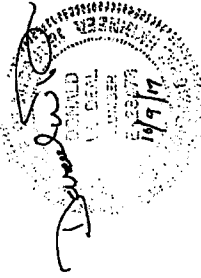

NO.	REVISION	DATE	BY	CHKD	DATE
0	ISSUED FOR PERMIT				

**ALLEN DESIGNS, LLC**

P.O. BOX 722, EL. NW, MO 63021  
TEL: 314-622-1892  
WWW.ALLENDIGNS.COM

**DONALD W. DEAL, P.E.**

PROFESSIONAL ENGINEER  
LICENSE NO. 623473  
PHONE: 314-622-1892  
P.O. BOX 722, EL. NW, MO 63021

**SITE PLAN AND SCOPE**

RESTAURANT RENOVATION  
1752-1754 N. NEW FLORISSANT RD  
FLORISSANT, MISSOURI 63033

PROJECT NO.  
**2017-112**

DRAWING NO.  
**A-0**





# ALLEN DESIGNS, LLC

P.O. BOX 722 ST. LOUIS, MO 63104  
TEL: 314-423-1057  
WWW.ALLENDZIGN.COM

1000 W. DEAL, P.E.  
PHONE: 314-423-1000  
ST. LOUIS, MO 63103  
LICENSE NO.: 024719

DRAWN BY: CJA  
CHECKED BY: DWD  
SCALE: AS SHOWN  
DATE: 8/20/17

PROPOSED FLOOR PLAN  
RESTAURANT RENOVATION  
1752-1764 N. NEW FLORISSANT RD  
FLORISSANT, MISSOURI 63033

PROJECT NO.: 2017-112  
DRAWING NO.: A-2

### GENERAL NOTES:

- CONSTRUCTION PER ALL GOVERNING CODES PER 2009 INTERNATIONAL BUILDING CODES.
- CONTRACTOR SHALL FIELD VERIFY ALL EXISTING CONDITIONS AND DIMENSIONS PRIOR TO CONSTRUCTION.
- ALL EXISTING REPAIR TO INTERIOR WALLS SHALL BE REPLACED WITH X-TYPE GYPSUM BOARD.
- ALL NEW PARTITION WALLS SHALL BE METAL STUD WALLS FOR TYPICAL METAL STUD DETAILS. SEE DRAWING A-4 UNLESS NOTED OTHERWISE.

### KEYED NOTES:

- PROVIDING SEPARATION WALL IS VERIFIED TO BE DOUBLE LAYER 5/8" GYPSUM BOARD, ADD A BEAD OF FIRE RATED CAULKING ALONG THE TOP ALONG CEILING JOINTS WHERE IT JOINS THE GYPSUM BOARD. SEE DRAWING A-4 FOR SPECIAL DETAILS.
- ADD PANIC BAR WITH ALARM TO SIDE DOOR. PANIC BAR ALARM SHALL READ "EMERGENCY EXIT ONLY - ALARM WILL SOUND".
- NEW EXIT SIGNS WITH EMERGENCY LIGHTS (TYP).
- PROPOSED BAR (BAR SUPPLIED BY OWNER).
- FINAL ORIENTATION OF APPLIANCES AND SINK ARE DETERMINED BY OWNER OR OWNER'S REPRESENTATIVE. NECESSARY RECEPTACLES FOR EACH APPLIANCE SHALL BE SUPPLIED BY QUALIFIED ELECTRICAL CONTRACTOR.
- FLOOR-SET MOP SINK. SEE DRAWING A-4 FOR DETAIL.

### LEGEND (ALL SYMBOLS MAY NOT BE USED):

- SMOKE DETECTOR - HARD WIRED WITH BATTERY BACKUP
- GROUND FAULT INDICATOR OUTLET
- RECEPTACLE OUTLET
- TRIPLE OUTLET
- PROPOSED LIGHT
- PROPOSED LIGHT/EXHAUST FAN
- NEW FLOOD LIGHT
- NEW WALL LIGHT
- NEW SWITCH
- NEW 3-WAY SWITCH
- EXIT SIGN
- EXIT SIGN WITH EMERGENCY LIGHTS

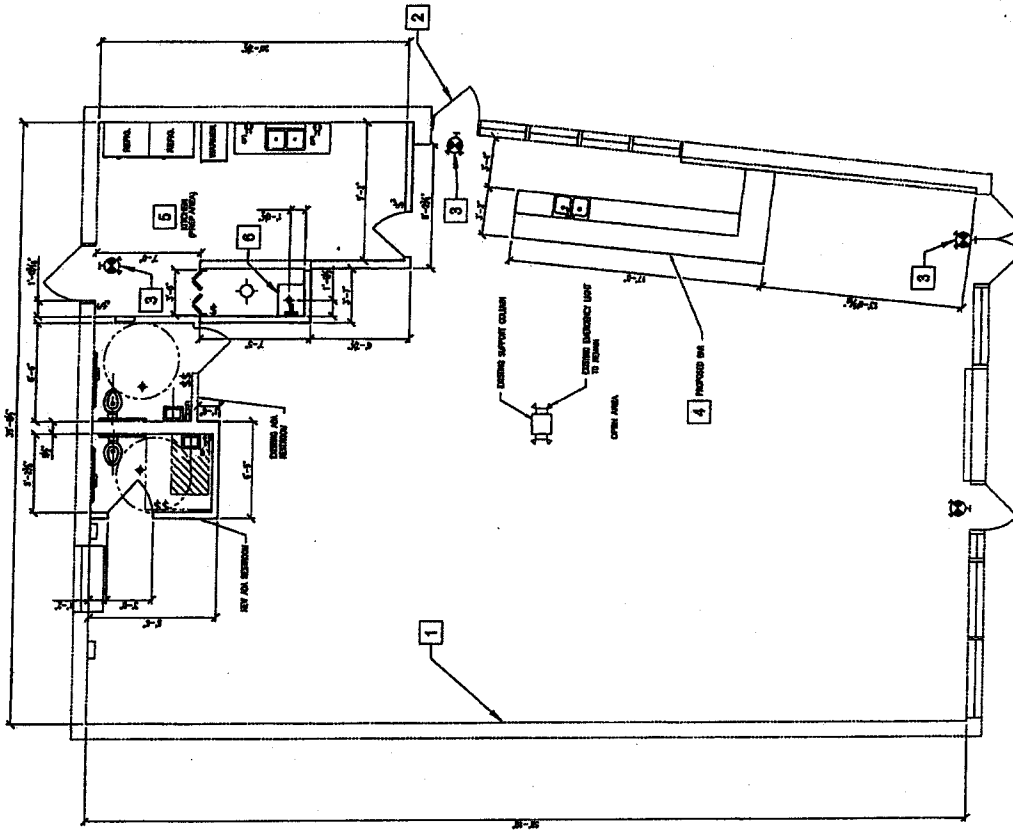

*Allen Designs*  
10/9/17



PROPOSED FLOOR PLAN  
SCALE: 1/4" = 1'-0"

NO.	DATE	DESCRIPTION	DWG.	APP'D.
0	8/20/17	ISSUED FOR PERMIT		

# ALLEN DESIGNS, LLC

P.O. BOX 724, ST. LOUIS, MO 63103  
 TEL: 314-622-1827  
 WWW.ALLENDISIGNS.COM

DONALD W. DEAL, P.E.  
 PROFESSIONAL ENGINEER  
 LICENSE NO. 62273  
 PHONE: 314-622-1827  
 27, LOUIS, MO 63103

DESIGNED BY: DONALD W. DEAL  
 CHECKED BY: ASH BROWN  
 DATE: 02/17/17

ENLARGED PROP. FLOOR PLAN  
 RESTAURANT RENOVATION  
 1752-1754 N. NEW FLOISSANT RD  
 FLOISSANT, MISSOURI 63033

PROJECT NO. 2017-112  
 DRAWING NO. A-3

### GENERAL NOTES:

1. CONTRACTOR SHALL FIELD VERIFY EXISTING CONDITIONS AND DIMENSIONS PRIOR TO CONSTRUCTION.
2. RESTROOMS SHALL COMPLY WITH 2010 ADA STANDARDS FOR STATE AND LOCAL GOVERNMENT FACILITIES.
3. TOILET AND WATER CLOSET SHALL COMPLY WITH 603 AND 604.
4. CONTRACTOR SHALL INSTALL PROPER DRAINAGE AND WATER SUPPLY FOR NEW SINK BASED UPON MANUFACTURERS SPECIFICATIONS.
5. FLOOR DRAINS WITHIN RESTROOMS ARE EXISTING. ADDITIONAL FLOOR DRAINS FOR BAR SHOULD BE FIELD LOCATED BY PLUMBING CONTRACTOR.

### KEYED NOTES:

- 1 NEW WALL WIDTH TO MATCH EXISTING CONNECTED WALL.

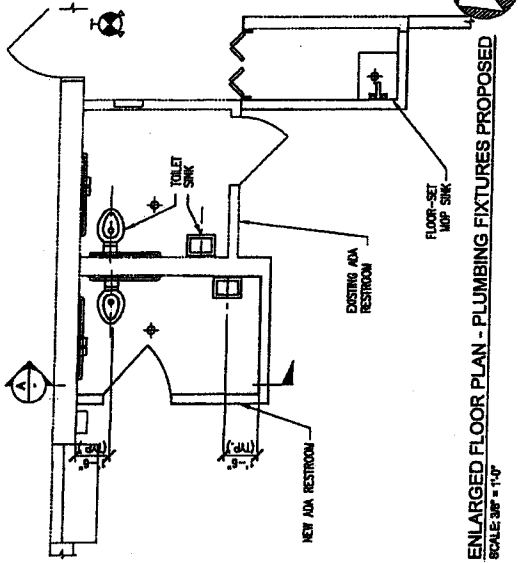

ENLARGED FLOOR PLAN - PLUMBING FIXTURES PROPOSED  
 SCALE: 3/8" = 1'-0"

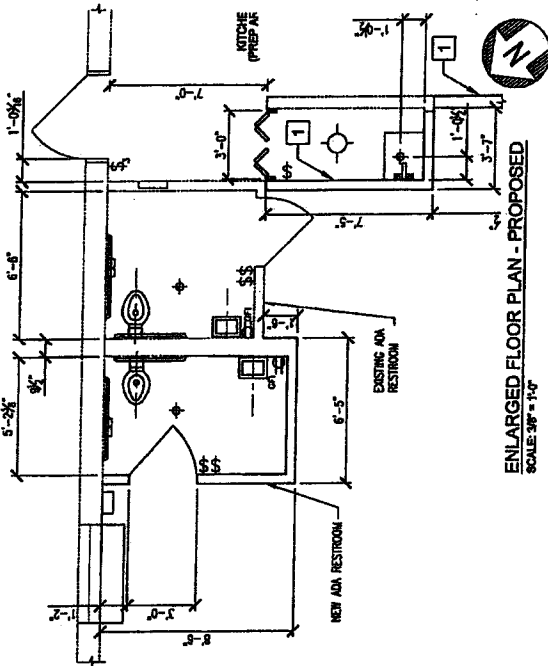

ENLARGED FLOOR PLAN - ADA PROPOSED  
 SCALE: 3/8" = 1'-0"

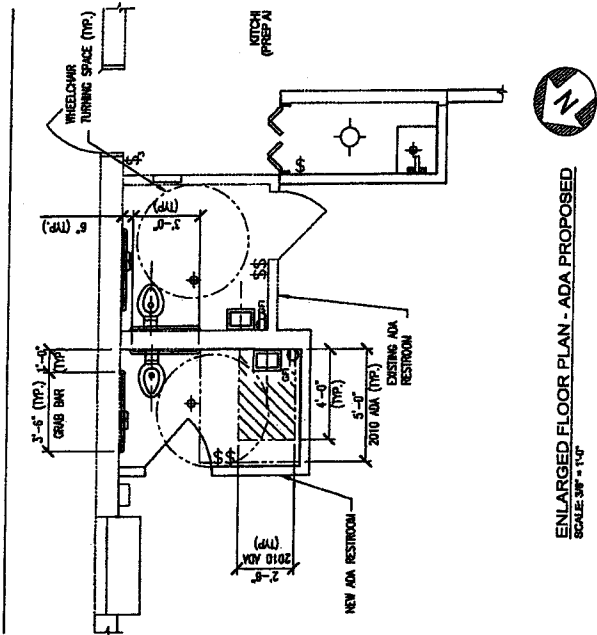

ENLARGED FLOOR PLAN - ADA PROPOSED  
 SCALE: 3/8" = 1'-0"

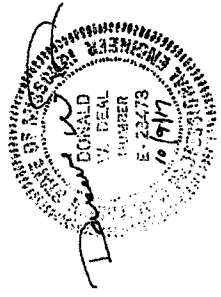

RESTROOM ELEVATION  
 SCALE: 3/8" = 1'-0"  
 NOTE: INDICATION ABOVE BROWN ONLY FOR PROPER FIXTURE ELEVATIONS.

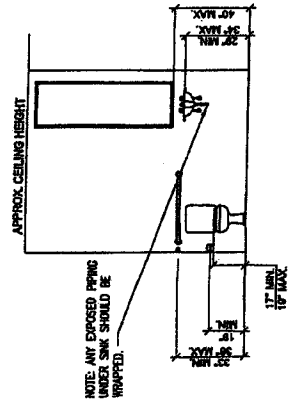

# ALLEN DESIGNS, LLC

P.O. BOX 172, ST. AVENUE CENTER  
 WWW.ALLENDIGNS.COM  
 TEL 314-832-1057

DONALD W. DEAL, P.E.  
 REGISTERED PROFESSIONAL ENGINEER  
 ST. LOUIS, MO 63102  
 LICENSE NO. 02973

DESIGNER  
 CHECKED BY  
 DATE  
 DRAWN BY  
 SCALE

SPECIAL DETAILS  
 RESTAURANT RENOVATION  
 1752-1754 N. NEW FLORISSANT RD  
 FLORISSANT, MISSOURI 63033

PROJECT NO.  
 2017-112  
 DRAWING NO.  
 A-4

### GENERAL NOTES:

- FLOOR SET MOP SINK BASED UPON REGENCY SINKS MODEL #003SM1020S OR EQUIVALENT. INSTALLING CONTRACTOR SHALL FIELD VERIFY PROPER DRAIN LOCATION AND MANUFACTURER'S SPECIFICATIONS. IMAGE SHOWN IS ONLY FOR DESIGN SPECIFICATIONS AND BASED UPON OWNER AND CONTRACTOR AGREEMENT.
- CONTRACTOR SHALL INSTALL PROPER PLUMBING ABOVE MOP SINK THAT IS ADEQUATE FOR THE USE OF VARIOUS JANITORIAL SUPPLIES.

FLOOR SET MOP SINK  
 TYPICAL OVERALL SIZE: 25"21"X10"

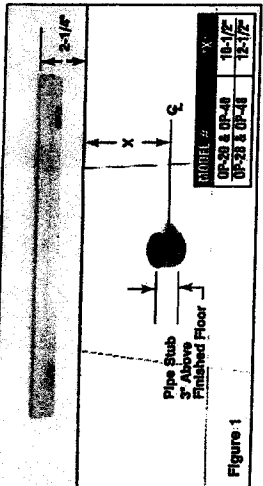

FLOOR MOUNTED MOP SINK DETAIL  
 SCALE: NONE

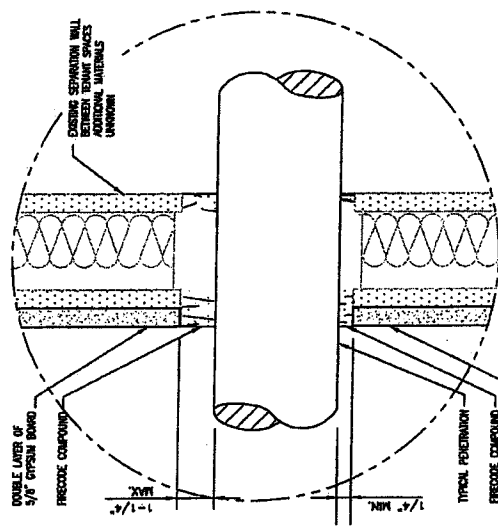

TYPICAL WALL PENETRATION DETAIL  
 SCALE: NONE

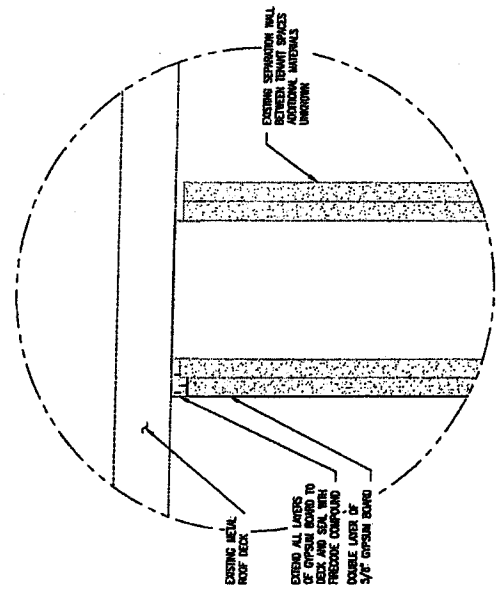

TYPICAL WALL TO ROOF DECK DETAIL  
 SCALE: NONE



NO.	REVISION/ISSUED FOR PERMIT	DATE	BY	APP'D
0	ISSUED FOR PERMIT			



**METAL STUD WALL GENERAL NOTES:**

- 1. ALL NEW WALLS ARE 4" WIDE, UNLESS NOTED OTHERWISE.

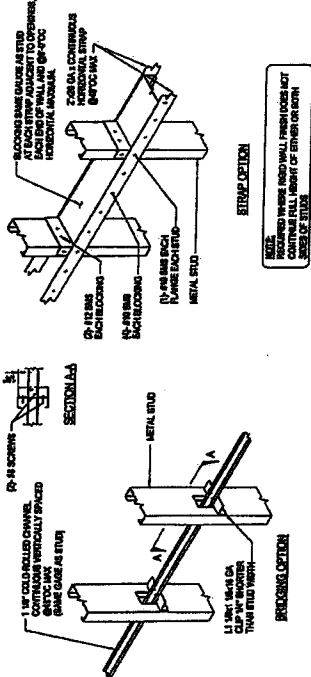

**TYPICAL LATERAL BRIDGING AT METAL STUDS**  
 SCALE: N.T.S.

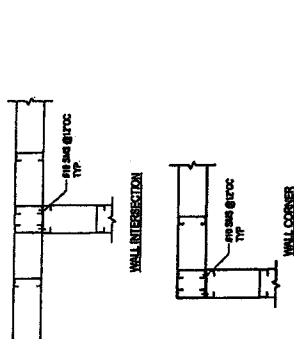

**TYPICAL METAL STUD WALL DETAILS AT INTERSECTION DETAILS**  
 SCALE: N.T.S.

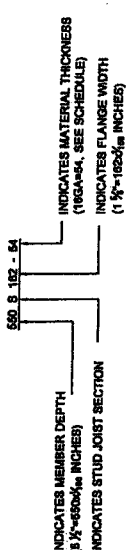

**METAL STUD IDENTIFICATION**  
 SCALE: N.T.S.

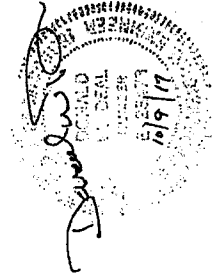

REV	DATE	DESCRIPTION	BY	APP'D
0		ISSUED FOR PERMIT		

1 INTRODUCED BY COUNCILMAN HENKE  
2 APRIL 9, 2018

3  
4 BILL NO. 9380 ORDINANCE NO. 8407

5  
6 **ORDINANCE AUTHORIZING A TRANSFER OF SPECIAL USE**  
7 **PERMIT NO. 8376 FROM 5 ACES BBQ TO CA44 LLC D/B/A HWY 67**  
8 **BBQ FOR THE OPERATION OF A RESTAURANT LOCATED AT**  
9 **1752-1754 N. NEW FLORISSANT ROAD.**

10  
11 WHEREAS, the Florissant Zoning Ordinance authorizes the Council of the City of  
12 Florissant, by Special Use Permit, after public hearing thereon, to permit the location and  
13 operation of a restaurant; and

14 WHEREAS, pursuant to Ordinance No. 8376, 5 Aces BBQ was granted a Special Use  
15 Permit for the location and operation of restaurant on the property known as 1752-1754 N. New  
16 Florissant Road; and

17 WHEREAS, an application has been filed by CA44 LLC d/b/a Hwy 67 BBQ to transfer  
18 the Special Use Permit authorized by Ordinance No. 8376 to its name; and

19 WHEREAS, the City Council of the City of Florissant determined at its meeting on  
20 April 9, 2018 that the business operated under Ordinance Nos. 8376 would be operated in a  
21 substantially identical fashion as set out herein; and

22 WHEREAS, CC44 LLC has accepted the terms and conditions set out in Ordinance No.  
23 8376.

24 NOW, THEREFORE, BE IT ORDAINED BY THE COUNCIL OF THE CITY OF  
25 FLORISSANT, ST. LOUIS COUNTY, MISSOURI, AS FOLLOWS:

26  
27 Section 1: The Special Use Permit authorized by Ordinance No. 8376 originally issued 5  
28 Aces BBQ is hereby transferred to CC44 LLC d/b/a Hwy 67 BBQ for the location and operation  
29 of a restaurant on the property known as 1752-1754 N. New Florissant Road.

30 Section 2: The terms and conditions of said Special Permit authorized by Ordinance No.  
31 8376 shall remain in full force and effect.

32 Section 3: The Special Use Permit herein authorized shall terminate if the said business  
33 ceases operation for a period of more than ninety (90) days.

34 Section 4: This ordinance shall become in force and effect immediately upon its passage  
35 and approval.

36

37

Adopted this 23 day of April, 2018.

38

39

40

41

42

43

44

45

  
Jackie Pagano  
Council President

46

Approved this 24 day of April, 2018.

47

48

49

50

51

52

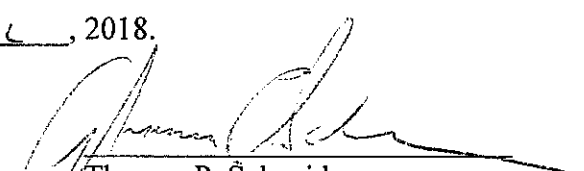
  
Thomas P. Schneider  
Mayor, City of Florissant

53

ATTEST:

54

55

56

57

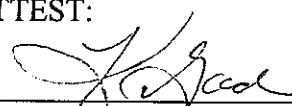
  
Karen Goodwin, MMC/MRCC  
City Clerk



1 INTRODUCED BY COUNCILMAN SIAM  
2 JUNE 27, 2022

3  
4 BILL NO. 9794

ORDINANCE NO.

5  
6 **ORDINANCE TO AMEND B-5 ORDINANCE NO. 5854 (AS**  
7 **AMENDED) TO ALLOW FOR CHANGES IN THE DRIVE-THRU**  
8 **FOR PANERA LLC. LOCATED AT 2375 N. HWY 67**

9  
10 WHEREAS, ordinance no. 5186 was passed in September of 1990 approving the  
11 rezoning of rezoning of the Gramex Development to a B-5 Planned Commercial District; and

12 WHEREAS ordinance no. 5854 was passed on June 10, 1996 amending ordinance no.  
13 5186 to allow for a restaurant on Outlot Parcel 1; and

14 WHEREAS ordinance no. 5854 was amended by ordinance no. 7322 on August 14, 2006  
15 to allow for a drive thru facility and additional signage for the property located at 2375 N. Hwy  
16 67; and

17 WHEREAS ordinance 5854 was further amended by ordinance no. 7962 on March 25,  
18 2013 to allow for the replacement of an existing wall sign; and

19 WHEREAS Panera LLC has applied for an amendment to the development plan  
20 authorized by ordinance 5854 to allow changes in the drive-thru located at 2375 N Hwy 67. and

21 WHEREAS, the Planning and Zoning Commission of the City of Florissant has  
22 recommended to the City Council at their meeting of June 6, 2022 that an amendment to B-5  
23 ordinance no. 5854 (as amended) as to allow for changes in the drive-thru for the property  
24 located at 2375 N. Hwy 67; and

25 WHEREAS, due and lawful notice of a public hearing no. 22-06-017 on said proposed  
26 change was duly published, held and concluded on 27th day of June, 2022 by the Council of the  
27 City of Florissant; and

28 WHEREAS, the Council, following said public hearing, and after due and careful  
29 deliberation, has concluded that that an amendment to B-5 ordinance no. 5854 (as amended) to  
30 allow for changes to the drive-thru for the property located at 2375 N. Hwy 67 is in the best  
31 interest of the public health, safety and welfare of the City of Florissant; and

32

33 NOW, THEREFORE, BE IT ORDAINED BY THE COUNCIL OF THE CITY OF  
34 FLORISSANT, ST. LOUIS COUNTY, MISSOURI, AS FOLLOWS:  
35

36 Section 1: There is hereby amended, the provisions of a ‘B-5’ Zoning District,  
37 located at 2375 N. Highway 67 (Panera, LLC) Ord. No. 5854 (as amended by Ords No. 7322 and  
38 7962) to allow for changes in the drive- thru as follows:

- 39 1.Ordinance No. 5854 granted to Panera, LLC for a ‘B-5’ Planned Commercial District  
40 Development shall be amended to allow for the addition of a drive thru lane with  
41 additional signage in accordance with attached drawings SP01 dated 5/5/2022, SP02  
42 dated 5/5/2022, LA01 dated 5/9/2022 and A101 dated 4/22/2022 by Civil &  
43 Environmental Consultants, Inc.
- 44 2.Ordinance No. 5854 shall otherwise remain in full force and effect.
- 45 3.Add protective bollards on south side.

46  
47 Section 2: This ordinance shall become in full force and effect immediately upon its  
48 passage and approval.  
49

50  
51 Adopted this \_\_\_\_\_ day of \_\_\_\_\_, 20\_\_.

52  
53  
54 \_\_\_\_\_  
55 Keith Schildroth  
56 President of the Council

57 Approved this \_\_\_\_\_ day of \_\_\_\_\_, 20\_\_.

58  
59  
60 \_\_\_\_\_  
61 Timothy J. Lowery  
62 Mayor, City of Florissant

63  
64 ATTEST:

65  
66 \_\_\_\_\_  
67 Karen Goodwin, MPPA/MMC/MRCC  
68 City Clerk

1 INTRODUCED BY COUNCIL AS A WHOLE  
2 JUNE 27, 2022

3  
4 BILL NO. 9795

Ordinance No.

5  
6 **ORDINANCE AUTHORIZING THE MAYOR OF THE CITY OF**  
7 **FLORISSANT TO ENTER INTO AN AGREEMENT WITH**  
8 **MISSOURI HIGHWAYS AND TRANSPORTATION COMMISSION**  
9 **FOR THE MULLANPHY ROAD PROJECT.**

10  
11  
12 NOW THEREFORE, BE IT ORDAINTED BY THE CITY COUNCIL OF THE CITY OF  
13 FLORISSANT, MISSOURI, AS FOLLOWS:

14  
15 Section 1. The Mayor of the City of Florissant is hereby authorized to enter in to an  
16 agreement with Missouri Highways and Transportation Commission for the Mullanphy Road  
17 Project.

18  
19 Section 2. This ordinance shall be in full force and effect from and after the date of  
20 its passage by the City Council.

21  
22  
23 Adopted this \_\_\_\_\_ day of \_\_\_\_\_, 2022.

24  
25 \_\_\_\_\_  
26 Joseph Eagan  
27 President of the City Council  
28

29  
30 Approved this \_\_\_\_\_ day of \_\_\_\_\_, 2022.

31  
32 \_\_\_\_\_  
33 Timothy J. Lowery  
34 Mayor  
35

36  
37 ATTEST:

38 \_\_\_\_\_  
39 Karen Goodwin, MPPA/MMC/MRCC  
40 City Clerk

CCO Form: FS11  
Approved: 07/96 (KMH)  
Revised: 03/17 (MWH)  
Modified:

CFDA Number: CFDA #20.205  
CFDA Title: Highway Planning and Construction  
Award name/number: STP-4901(650)  
Award Year: 2023  
Federal Agency: Federal Highway Administration, Department of Transportation

**MISSOURI HIGHWAYS AND TRANSPORTATION COMMISSION  
STP-URBAN PROGRAM AGREEMENT**

THIS STP-URBAN AGREEMENT is entered into by the Missouri Highways and Transportation Commission (hereinafter, "Commission") and the City of Florissant, St. Louis County, Missouri (hereinafter, "City").

WITNESSETH:

WHEREAS, the Fixing America's Surface Transportation Act (FAST) 23 U.S.C. §133, authorizes a Surface Transportation Program (STP) to fund transportation related projects; and

WHEREAS, the City desires to construct certain improvements, more specifically described below, using such STP funding; and

WHEREAS, those improvements are to be designed and constructed in compliance with the provisions of this Agreement.

NOW, THEREFORE, in consideration of the mutual covenants, promises and representations in this Agreement, the parties agree as follows:

(1) PURPOSE: The purpose of this Agreement is to grant the use of STP funds to the City. The improvement contemplated by this Agreement and designated as Project STP-4901(650) involves:

Resurfacing, replacement of damaged or deteriorated curb and sidewalk, construction of accessible curb ramps and new sidewalk.

The City shall be responsible for all aspects of the construction of the improvement.

(2) LOCATION: The contemplated improvement designated as Project STP-4901(650) by the Commission is within the city limits of Florissant, Missouri. The general location of the improvement is shown on an attachment hereto marked "Exhibit A" and incorporated herein by reference. More specific descriptions are as follows:

Mullanphy Road from Patterson Road to Fernbrook Drive. Sidewalk will be extended from Vesper Drive to Fernbrook Drive.

(3) REASONABLE PROGRESS POLICY: The project as described in this agreement is subject to the reasonable progress policy set forth in the Local Public Agency (LPA) Manual and the final deadline specified in Exhibit B attached hereto and incorporated herein by reference. In the event, the LPA Manual and the final deadline within Exhibit B conflict, the final deadline within Exhibit B controls. If the project is within a Transportation Management Area that has a reasonable progress policy in place, the project is subject to that policy. If the project is withdrawn for not meeting reasonable progress, the City agrees to repay the Commission for any progress payments made to the City for the project and agrees that the Commission may deduct progress payments made to the City from future payments to the City.

(4) LIMITS OF SYSTEM: The limits of the surface transportation system for the City shall correspond to its geographical area as encompassed by the urban boundaries of the City as fixed cooperatively by the parties subject to approval by the Federal Highway Administration (FHWA).

(5) ROUTES TO BE INCLUDED: The City shall select the high traffic volume arterial and collector routes to be included in the surface transportation system, to be concurred with by the Commission, subject to approval by the FHWA. It is understood by the parties that surface transportation system projects will be limited to the said surface transportation system, but that streets and arterial routes may be added to the surface transportation system, including transfers from other federal aid systems.

(6) INVENTORY AND INSPECTION: The City shall:

(A) Furnish annually, upon request from the Commission or FHWA, information concerning conditions on streets included in the STP system under local jurisdiction indicating miles of system by pavement width, surface type, number of lanes and traffic volume category.

(B) Inspect and provide inventories of all bridges on that portion of the federal-aid highway systems under the jurisdiction of the City in accordance with the Federal Special Bridge Program, as set forth in 23 U.S.C. §144, and applicable amendments or regulations promulgated thereunder.

(7) CITY TO MAINTAIN: Upon completion of construction of this improvement, the City shall accept control and maintenance of the improved street and shall thereafter

keep, control, and maintain the same as, and for all purposes, a part of the City street system at its own cost and expense and at no cost and expense whatsoever to the Commission. Any traffic signals installed on highways maintained by the Commission will be turned over to the Commission upon completion of the project for maintenance. All obligations of the Commission under this Agreement shall cease upon completion of the improvement.

(8) INDEMNIFICATION:

(A) To the extent allowed or imposed by law, the City shall defend, indemnify and hold harmless the Commission, including its members and the Missouri Department of Transportation (MoDOT or Department) employees, from any claim or liability whether based on a claim for damages to real or personal property or to a person for any matter relating to or arising out of the City's wrongful or negligent performance of its obligations under this Agreement.

(B) The City will require any contractor procured by the City to work under this Agreement:

1. To obtain a no cost permit from the Commission's district engineer prior to working on the Commission's right-of-way, which shall be signed by an authorized contractor representative (a permit from the Commission's district engineer will not be required for work outside of the Commission's right-of-way); and

2. To carry commercial general liability insurance and commercial automobile liability insurance from a company authorized to issue insurance in Missouri, and to name the Commission, and MoDOT and its employees, as additional named insureds in amounts sufficient to cover the sovereign immunity limits for Missouri public entities as calculated by the Missouri Department of Insurance, Financial Institutions and Professional Registration, and published annually in the Missouri Register pursuant to Section 537.610, RSMo. The City shall cause insurer to increase the insurance amounts in accordance with those published annually in the Missouri Register pursuant to Section 537.610, RSMo.

(C) In no event shall the language of this Agreement constitute or be construed as a waiver or limitation for either party's rights or defenses with regard to each party's applicable sovereign, governmental, or official immunities and protections as provided by federal and state constitution or law.

(9) CONSTRUCTION SPECIFICATIONS: Parties agree that all construction under the STP for the City will be constructed in accordance with current MoDOT design criteria/specifications for urban construction unless separate standards for the surface transportation system have been established by the City and the Commission subject to the approval of the FHWA.

(10) FEDERAL-AID PROVISIONS: Because responsibility for the performance of all functions or work contemplated as part of this project is assumed by the City, and the City may elect to construct part of the improvement contemplated by this Agreement with its own forces, a copy of Section II and Section III, as contained in the United States Department of Transportation Form Federal Highway Administration (FHWA) 1273 "Required Contract Provisions, Federal-Aid Construction Contracts," is attached and made a part of this Agreement as Exhibit C. Wherever the term "the contractor" or words of similar import appear in these sections, the term "the City" is to be substituted. The City agrees to abide by and carry out the condition and obligations of "the contractor" as stated in Section II, Equal Opportunity, and Section III, Nonsegregated Facilities, as set out in Form FHWA 1273.

(11) ACQUISITION OF RIGHT OF WAY: With respect to the acquisition of right of way necessary for the completion of the project, City shall acquire any additional necessary right of way required for the project and in doing so agrees that it will comply with all applicable federal laws, rules and regulations, including 42 U.S.C. 4601-4655, the Uniform Relocation Assistance and Real Property Acquisition Act, as amended and any regulations promulgated in connection with the Act. However upon written request by the City and the written acceptance by the Commission, the Commission shall acquire right of way for the City. Upon approval of all agreements, plans and specifications by the Commission and the FHWA, the commission will file copies of said plans in the office of the county clerk: and proceed to acquire by negotiation and purchase or by condemnation any necessary right of way required for the construction of the improvement contemplated herein. All right of way acquired by negotiation and purchase will be acquired in the name of City, and the City will pay to grantors thereof the agreed upon purchase prices. All right of way acquired through condemnation proceedings will be acquired in the name of the State of Missouri and subsequently released to the City. The City shall pay into court all awards and final judgments in favor of any such condemnees. The City shall also reimburse the Commission for any expense incurred by the Commission in acquiring said right of way, including but not limited to the costs of surveying, appraisal, negotiation, condemnation, and relocation assistance benefits. Unless otherwise agreed to in writing the Commission shall have the final decision regarding the settlement amount in condemnation.

(12) REIMBURSEMENT: The cost of the contemplated improvements will be borne by the United States Government and by the City as follows:

(A) Any federal funds for project activities shall only be available for reimbursement of eligible costs which have been incurred by City. Any costs incurred by City prior to authorization from FHWA and notification to proceed from the Commission are **not** reimbursable costs. All federally funded projects are required to have a project end date. Any costs incurred after the project end date are not eligible for reimbursement. The federal share for this project will be 80 percent not to exceed \$660,800. The calculated federal share for seeking federal reimbursement of participating costs for the herein improvements will be determined by dividing the total federal funds applied to the

project by the total participating costs. Any costs for the herein improvements which exceed any federal reimbursement or are not eligible for federal reimbursement shall be the sole responsibility of City. The Commission shall not be responsible for any costs associated with the herein improvement unless specifically identified in this Agreement or subsequent written amendments.

(B) The total reimbursement otherwise payable to the City under this Agreement is subject to reduction, offset, levy, judgment, collection or withholding, if there is a reduction in the available federal funding, or to satisfy other obligations of the City to the Commission, the State of Missouri, the United States, or another entity acting pursuant to a lawful court order, which City obligations or liability are created by law, judicial action, or by pledge, contract or other enforceable instrument. Any costs incurred by the City prior to authorization from FHWA and notification to proceed from the Commission are not reimbursable costs.

(13) PERMITS: The City shall secure any necessary approvals or permits from the Federal Government and the State of Missouri as required to permit the construction and maintenance of the contemplated improvements.

(14) TRAFFIC CONTROL: The plans shall provide for handling traffic with signs, signal and marking in accordance with the Manual of Uniform Traffic Control Devices (MUTCD).

(15) WORK ON STATE RIGHT OF WAY: If any contemplated improvements for Project STP-4901(650) will involve work on the state's right of way, the City will provide reproducible final plans to the Commission relating to such work.

(16) DISADVANTAGED BUSINESS ENTERPRISES (DBEs): At time of processing the required project agreements with the FHWA, the Commission will advise the City of any required goals for participation by DBEs to be included in the City's proposal for the work to be performed. The City shall submit for Commission approval a DBE goal or plan. The City shall comply with the plan or goal that is approved by the Commission and all requirements of 49 C.F.R. Part 26, as amended.

(17) NOTICE TO BIDDERS: The City shall notify the prospective bidders that disadvantaged business enterprises shall be afforded full and affirmative opportunity to submit bids in response to the invitation and will not be discriminated against on grounds of race, color, sex, or national origin in consideration for an award.

(18) PROGRESS PAYMENTS: The City may request progress payments be made for the herein improvements as work progresses but not more than once every two weeks. Progress payments must be submitted monthly. All progress payment requests must be submitted for reimbursement within 90 days of the project completion date for the final phase of work. The City shall repay any progress payments which involve ineligible costs.



(19) PROMPT PAYMENTS: Progress invoices submitted to MoDOT for reimbursement more than thirty (30) calendar days after the date of the vendor invoice shall also include documentation that the vendor was paid in full for the work identified in the progress invoice. Examples of proof of payment may include a letter or e-mail from the vendor, lien waiver or copies of cancelled checks. Reimbursement will not be made on these submittals until proof of payment is provided. Progress invoices submitted to MoDOT for reimbursement within thirty (30) calendar days of the date on the vendor invoice will be processed for reimbursement without proof of payment to the vendor. If the City has not paid the vendor prior to receiving reimbursement, the City must pay the vendor within two (2) business days of receipt of funds from MoDOT.

(20) OUTDOOR ADVERTISING: The City further agrees that the right of way provided for any STP improvement will be held and maintained inviolate for public highway or street purposes, and will enact and enforce any ordinances or regulations necessary to prohibit the presence of billboards or other advertising signs or devices and the vending or sale of merchandise on such right of way, and will remove or cause to be removed from such right of way any sign, private installation of any nature, or any privately owned object or thing which may interfere with the free flow of traffic or impair the full use and safety of the highway or street.

(21) FINAL AUDIT: The Commission will perform a final audit of project costs. The United States Government shall reimburse the City, through the Commission, any monies due. The City shall refund any overpayments as determined by the final audit.

(22) AUDIT REQUIREMENT: If the City expend(s) seven hundred fifty thousand dollars (\$750,000) or more in a year in federal financial assistance it is required to have an independent annual audit conducted in accordance with 2 CFR Part 200. A copy of the audit report shall be submitted to MoDOT within the earlier of thirty (30) days after receipt of the auditor's report(s), or nine (9) months after the end of the audit period. Subject to the requirements of 2 CFR Part 200, if the City expend(s) less than seven hundred fifty thousand dollars (\$750,000) a year, the City may be exempt from auditing requirements for that year but records must be available for review or audit by applicable state and federal authorities.

(23) FEDERAL FUNDING ACCOUNTABILITY AND TRANSPARENCY ACT OF 2006: The City shall comply with all reporting requirements of the Federal Funding Accountability and Transparency Act (FFATA) of 2006, as amended. This Agreement is subject to the award terms within 2 C.F.R. Part 170.

(24) VENUE: It is agreed by the parties that any action at law, suit in equity, or other judicial proceeding to enforce or construe this Agreement, or regarding its alleged breach, shall be instituted only in the Circuit Court of Cole County, Missouri.

(25) LAW OF MISSOURI TO GOVERN: This Agreement shall be construed according to the laws of the State of Missouri. The City shall comply with all local, state and federal laws and regulations relating to the performance of this Agreement.

(26) AMENDMENTS: Any change in this Agreement, whether by modification or supplementation, must be accomplished by a formal contract amendment signed and approved by the duly authorized representatives of the City and the Commission.

(27) COMMISSION REPRESENTATIVE: The Commission's St. Louis District Engineer is designated as the Commission's representative for the purpose of administering the provisions of this Agreement. The Commission's representative may designate by written notice other persons having the authority to act on behalf of the Commission in furtherance of the performance of this Agreement.

(28) NOTICES: Any notice or other communication required or permitted to be given hereunder shall be in writing and shall be deemed given three (3) days after delivery by United States mail, regular mail postage prepaid, or upon receipt by personal or facsimile delivery, addressed as follows:

- (A) To the City:  
955 Rue St. Francois  
Florissant, MO 63031
- (B) To the Commission:  
1590 Woodlake Drive  
Chesterfield, MO 63017

or to such other place as the parties may designate in accordance with this Agreement. To be valid, facsimile delivery shall be followed by delivery of the original document, or a clear and legible copy thereof, within three (3) business days of the date of facsimile transmission of that document.

(29) NONDISCRIMINATION ASSURANCE: With regard to work under this Agreement, the City agrees as follows:

(A) Civil Rights Statutes: The City shall comply with all state and federal statutes relating to nondiscrimination, including but not limited to Title VI and Title VII of the Civil Rights Act of 1964, as amended (42 U.S.C. §2000d and §2000e, et seq.), as well as any applicable titles of the "Americans with Disabilities Act" (42 U.S.C. §12101, et seq.). In addition, if the City is providing services or operating programs on behalf of the Department or the Commission, it shall comply with all applicable provisions of Title II of the "Americans with Disabilities Act".

(B) Administrative Rules: The City shall comply with

the administrative rules of the United States Department of Transportation relative to nondiscrimination in federally-assisted programs of the United States Department of Transportation (49 C.F.R. Part 21) which are herein incorporated by reference and made part of this Agreement.

(C) Nondiscrimination: The City shall not discriminate on grounds of the race, color, religion, sex, disability, national origin, age or ancestry of any individual in the selection and retention of subcontractors, including procurement of materials and leases of equipment. The City shall not participate either directly or indirectly in the discrimination prohibited by 49 C.F.R. §21.5, including employment practices.

(D) Solicitations for Subcontracts, Including Procurements of Material and Equipment: These assurances concerning nondiscrimination also apply to subcontractors and suppliers of the City. These apply to all solicitations either by competitive bidding or negotiation made by the City for work to be performed under a subcontract including procurement of materials or equipment. Each potential subcontractor or supplier shall be notified by the City of the requirements of this Agreement relative to nondiscrimination on grounds of the race, color, religion, sex, disability or national origin, age or ancestry of any individual.

(E) Information and Reports: The City shall provide all information and reports required by this Agreement, or orders and instructions issued pursuant thereto, and will permit access to its books, records, accounts, other sources of information, and its facilities as may be determined by the Commission or the United States Department of Transportation to be necessary to ascertain compliance with other contracts, orders and instructions. Where any information required of the City is in the exclusive possession of another who fails or refuses to furnish this information, the City shall so certify to the Commission or the United States Department of Transportation as appropriate and shall set forth what efforts it has made to obtain the information.

(F) Sanctions for Noncompliance: In the event the City fails to comply with the nondiscrimination provisions of this Agreement, the Commission shall impose such contract sanctions as it or the United States Department of Transportation may determine to be appropriate, including but not limited to:

1. Withholding of payments under this Agreement until the City complies; and/or
2. Cancellation, termination or suspension of this Agreement, in whole or in part, or both.

(G) Incorporation of Provisions: The City shall include the provisions of paragraph (29) of this Agreement in every subcontract, including procurements of materials and leases of equipment, unless exempted by the statutes, executive order, administrative rules or instructions issued by the Commission or the United States

Department of Transportation. The City will take such action with respect to any subcontract or procurement as the Commission or the United States Department of Transportation may direct as a means of enforcing such provisions, including sanctions for noncompliance; provided that in the event the City becomes involved or is threatened with litigation with a subcontractor or supplier as a result of such direction, the City may request the United States to enter into such litigation to protect the interests of the United States.

(30) ACCESS TO RECORDS: The City and its contractors must maintain all records relating to this Agreement, including but not limited to invoices, payrolls, etc. These records must be available at no charge to the FHWA and the Commission and/or their designees or representatives during the period of this Agreement and any extension, and for a period of three (3) years after the date on which the City receives reimbursement of their final invoice from the Commission.

(31) CONFLICT OF INTEREST: The City shall comply with conflict of interest policies identified in 23 CFR 1.33. A conflict of interest occurs when an entity has a financial or personal interest in a federally funded project.

(32) MANDATORY DISCLOSURES: The City shall comply with 2 CFR 200.113 and disclose, in a timely manner, in writing all violations of Federal criminal law involving fraud, bribery, or gratuity violations potentially affecting the Federal award.

IN WITNESS WHEREOF, the parties have entered into this Agreement on the date last written below.

Executed by the City on \_\_\_\_\_(DATE).

Executed by the Commission on \_\_\_\_\_(DATE).

MISSOURI HIGHWAYS AND  
TRANSPORTATION COMMISSION

CITY OF FLORISSANT

\_\_\_\_\_  
Title \_\_\_\_\_

By \_\_\_\_\_  
Title \_\_\_\_\_

ATTEST:

ATTEST:

\_\_\_\_\_  
Secretary to the Commission

By \_\_\_\_\_  
Title \_\_\_\_\_

Approved as to Form:

Approved as to Form:

\_\_\_\_\_  
Commission Counsel

By \_\_\_\_\_  
Title \_\_\_\_\_

Ordinance No:\_\_\_\_\_

Exhibit A - Location of Project





## Exhibit B – Project Schedule

Project Description: STP-4901(650) Mullanphy Road

PROJECT DEVELOPMENT SCHEDULE			
<i>Note: many stages can occur concurrently.</i>			
Activity Description	Start Date (MM/YYYY)	Finish Date (MM/YYYY)	Time Frame (Months)
Receive notification letter	10/2021	10/2021	1
Execute agreement (project sponsor and DOT)	05/2022	07/2022	3
<b>Engineering services contract submitted and approved*</b>	08/2022	10/2022	3
Obtain environmental clearances (106, CE2, T&E, etc.)	10/2022	08/2022	11
Public meeting/hearing	05/2023	05/2023	1
Develop and submit preliminary plans	10/2022	05/2023	8
Preliminary plans approved	06/2023	06/2023	1
Develop and submit right-of-way plans	05/2023	07/2023	3
Review and approval of right-of-way plans	08/2023	08/2023	1
<b>Submit and receive approval for notice to proceed for right-of-way acquisition (A-Date)*</b>	08/2023	10/2023	3
Right-of-way acquisition	11/2023	06/2024	8
Utility coordination	10/2022	07/2024	22
Develop and submit PS&E	07/2023	07/2024	12
<b>District approval of PS&amp;E/advertise for bids*</b>	08/2024	10/2024	3
Submit and receive bids for review and approval	11/2024	12/2024	2
Project implementation/construction	01/2025	09/2025	10
* Finish date must match fiscal year for each milestone shown in <b>bold text</b> .			

\*Note: the dates established in the schedule above will be used in the applicable ESC between the sponsor agency and consultant firm.

\*\*Schedule dates are approximate as the project schedule will be actively managed and issues mitigated through the project delivery process. The Award Date or Planning Study Date deliverable is not approximate and requires request to adjust.

## Exhibit C - Required Contract Provisions

### REQUIRED CONTRACT PROVISIONS FEDERAL-AID CONSTRUCTION CONTRACTS

- I. General
- II. Nondiscrimination
- III. Nonsegregated Facilities
- IV. Davis-Bacon and Related Act Provisions
- V. Contract Work Hours and Safety Standards Act Provisions
- VI. Subletting or Assigning the Contract
- VII. Safety: Accident Prevention
- VIII. False Statements Concerning Highway Projects
- IX. Implementation of Clean Air Act and Federal Water Pollution Control Act
- X. Compliance with Governmentwide Suspension and Debarment Requirements
- XI. Certification Regarding Use of Contract Funds for Lobbying

#### ATTACHMENTS

A. Employment and Materials Preference for Appalachian Development Highway System or Appalachian Local Access Road Contracts (included in Appalachian contracts only)

#### I. GENERAL

1. Form FHWA-1273 must be physically incorporated in each construction contract funded under Title 23 (excluding emergency contracts solely intended for debris removal). The contractor (or subcontractor) must insert this form in each subcontract and further require its inclusion in all lower tier subcontracts (excluding purchase orders, rental agreements and other agreements for supplies or services).

The applicable requirements of Form FHWA-1273 are incorporated by reference for work done under any purchase order, rental agreement or agreement for other services. The prime contractor shall be responsible for compliance by any subcontractor, lower-tier subcontractor or service provider.

Form FHWA-1273 must be included in all Federal-aid design-build contracts, in all subcontracts and in lower tier subcontracts (excluding subcontracts for design services, purchase orders, rental agreements and other agreements for supplies or services). The design-builder shall be responsible for compliance by any subcontractor, lower-tier subcontractor or service provider.

Contracting agencies may reference Form FHWA-1273 in bid proposal or request for proposal documents, however, the Form FHWA-1273 must be physically incorporated (not referenced) in all contracts, subcontracts and lower-tier subcontracts (excluding purchase orders, rental agreements and other agreements for supplies or services related to a construction contract).

2. Subject to the applicability criteria noted in the following sections, these contract provisions shall apply to all work performed on the contract by the contractor's own organization and with the assistance of workers under the contractor's immediate superintendence and to all work performed on the contract by piecework, station work, or by subcontract.

3. A breach of any of the stipulations contained in these Required Contract Provisions may be sufficient grounds for withholding of progress payments, withholding of final payment, termination of the contract, suspension / debarment or any other action determined to be appropriate by the contracting agency and FHWA.

4. Selection of Labor: During the performance of this contract, the contractor shall not use convict labor for any purpose within the limits of a construction project on a Federal-aid highway unless it is labor performed by convicts who are on parole, supervised release, or probation. The term Federal-aid highway does not include roadways functionally classified as local roads or rural minor collectors.

#### II. NONDISCRIMINATION

The provisions of this section related to 23 CFR Part 230 are applicable to all Federal-aid construction contracts and to all related construction subcontracts of \$10,000 or more. The provisions of 23 CFR Part 230 are not applicable to material supply, engineering, or architectural service contracts.

In addition, the contractor and all subcontractors must comply with the following policies: Executive Order 11246, 41 CFR 60, 29 CFR 1625-1627, Title 23 USC Section 140, the Rehabilitation Act of 1973, as amended (29 USC 794), Title VI of the Civil Rights Act of 1964, as amended, and related regulations including 49 CFR Parts 21, 26 and 27; and 23 CFR Parts 200, 230, and 633.

The contractor and all subcontractors must comply with: the requirements of the Equal Opportunity Clause in 41 CFR 60-1.4(b) and, for all construction contracts exceeding \$10,000, the Standard Federal Equal Employment Opportunity Construction Contract Specifications in 41 CFR 60-4.3.

Note: The U.S. Department of Labor has exclusive authority to determine compliance with Executive Order 11246 and the policies of the Secretary of Labor including 41 CFR 60, and 29 CFR 1625-1627. The contracting agency and the FHWA have the authority and the responsibility to ensure compliance with Title 23 USC Section 140, the Rehabilitation Act of 1973, as amended (29 USC 794), and Title VI of the Civil Rights Act of 1964, as amended, and related regulations including 49 CFR Parts 21, 26 and 27; and 23 CFR Parts 200, 230, and 633.

The following provision is adopted from 23 CFR 230, Appendix A, with appropriate revisions to conform to the U.S. Department of Labor (US DOL) and FHWA requirements.

1. **Equal Employment Opportunity:** Equal employment opportunity (EEO) requirements not to discriminate and to take affirmative action to assure equal opportunity as set forth under laws, executive orders, rules, regulations (28 CFR 35, 29 CFR 1630, 29 CFR 1625-1627, 41 CFR 60 and 49 CFR 27) and orders of the Secretary of Labor as modified by the provisions prescribed herein, and imposed pursuant to 23 U.S.C. 140 shall constitute the EEO and specific affirmative action standards for the contractor's project activities under



this contract. The provisions of the Americans with Disabilities Act of 1990 (42 U.S.C. 12101 et seq.) set forth under 28 CFR 35 and 29 CFR 1630 are incorporated by reference in this contract. In the execution of this contract, the contractor agrees to comply with the following minimum specific requirement activities of EEO:

a. The contractor will work with the contracting agency and the Federal Government to ensure that it has made every good faith effort to provide equal opportunity with respect to all of its terms and conditions of employment and in their review of activities under the contract.

b. The contractor will accept as its operating policy the following statement:

"It is the policy of this Company to assure that applicants are employed, and that employees are treated during employment, without regard to their race, religion, sex, color, national origin, age or disability. Such action shall include: employment, upgrading, demotion, or transfer; recruitment or recruitment advertising; layoff or termination; rates of pay or other forms of compensation; and selection for training, including apprenticeship, pre-apprenticeship, and/or on-the-job training."

2. **EEO Officer:** The contractor will designate and make known to the contracting officers an EEO Officer who will have the responsibility for and must be capable of effectively administering and promoting an active EEO program and who must be assigned adequate authority and responsibility to do so.

3. **Dissemination of Policy:** All members of the contractor's staff who are authorized to hire, supervise, promote, and discharge employees, or who recommend such action, or who are substantially involved in such action, will be made fully cognizant of, and will implement, the contractor's EEO policy and contractual responsibilities to provide EEO in each grade and classification of employment. To ensure that the above agreement will be met, the following actions will be taken as a minimum:

a. Periodic meetings of supervisory and personnel office employees will be conducted before the start of work and then not less often than once every six months, at which time the contractor's EEO policy and its implementation will be reviewed and explained. The meetings will be conducted by the EEO Officer.

b. All new supervisory or personnel office employees will be given a thorough indoctrination by the EEO Officer, covering all major aspects of the contractor's EEO obligations within thirty days following their reporting for duty with the contractor.

c. All personnel who are engaged in direct recruitment for the project will be instructed by the EEO Officer in the contractor's procedures for locating and hiring minorities and women.

d. Notices and posters setting forth the contractor's EEO policy will be placed in areas readily accessible to employees, applicants for employment and potential employees.

e. The contractor's EEO policy and the procedures to implement such policy will be brought to the attention of employees by means of meetings, employee handbooks, or other appropriate means.

4. **Recruitment:** When advertising for employees, the contractor will include in all advertisements for employees the notation: "An Equal Opportunity Employer." All such advertisements will be placed in publications having a large circulation among minorities and women in the area from which the project work force would normally be derived.

a. The contractor will, unless precluded by a valid bargaining agreement, conduct systematic and direct recruitment through public and private employee referral sources likely to yield qualified minorities and women. To meet this requirement, the contractor will identify sources of potential minority group employees, and establish with such identified sources procedures whereby minority and women applicants may be referred to the contractor for employment consideration.

b. In the event the contractor has a valid bargaining agreement providing for exclusive hiring hall referrals, the contractor is expected to observe the provisions of that agreement to the extent that the system meets the contractor's compliance with EEO contract provisions. Where implementation of such an agreement has the effect of discriminating against minorities or women, or obligates the contractor to do the same, such implementation violates Federal nondiscrimination provisions.

c. The contractor will encourage its present employees to refer minorities and women as applicants for employment. Information and procedures with regard to referring such applicants will be discussed with employees.

5. **Personnel Actions:** Wages, working conditions, and employee benefits shall be established and administered, and personnel actions of every type, including hiring, upgrading, promotion, transfer, demotion, layoff, and termination, shall be taken without regard to race, color, religion, sex, national origin, age or disability. The following procedures shall be followed:

a. The contractor will conduct periodic inspections of project sites to insure that working conditions and employee facilities do not indicate discriminatory treatment of project site personnel.

b. The contractor will periodically evaluate the spread of wages paid within each classification to determine any evidence of discriminatory wage practices.

c. The contractor will periodically review selected personnel actions in depth to determine whether there is evidence of discrimination. Where evidence is found, the contractor will promptly take corrective action. If the review indicates that the discrimination may extend beyond the actions reviewed, such corrective action shall include all affected persons.

d. The contractor will promptly investigate all complaints of alleged discrimination made to the contractor in connection with its obligations under this contract, will attempt to resolve such complaints, and will take appropriate corrective action within a reasonable time. If the investigation indicates that the discrimination may affect persons other than the complainant, such corrective action shall include such other persons. Upon completion of each investigation, the contractor will inform every complainant of all of their avenues of appeal.

6. **Training and Promotion:**

a. The contractor will assist in locating, qualifying, and increasing the skills of minorities and women who are

applicants for employment or current employees. Such efforts should be aimed at developing full journey level status employees in the type of trade or job classification involved.

b. Consistent with the contractor's work force requirements and as permissible under Federal and State regulations, the contractor shall make full use of training programs, i.e., apprenticeship, and on-the-job training programs for the geographical area of contract performance. In the event a special provision for training is provided under this contract, this subparagraph will be superseded as indicated in the special provision. The contracting agency may reserve training positions for persons who receive welfare assistance in accordance with 23 U.S.C. 140(a).

c. The contractor will advise employees and applicants for employment of available training programs and entrance requirements for each.

d. The contractor will periodically review the training and promotion potential of employees who are minorities and women and will encourage eligible employees to apply for such training and promotion.

**7. Unions:** If the contractor relies in whole or in part upon unions as a source of employees, the contractor will use good faith efforts to obtain the cooperation of such unions to increase opportunities for minorities and women. Actions by the contractor, either directly or through a contractor's association acting as agent, will include the procedures set forth below:

a. The contractor will use good faith efforts to develop, in cooperation with the unions, joint training programs aimed toward qualifying more minorities and women for membership in the unions and increasing the skills of minorities and women so that they may qualify for higher paying employment.

b. The contractor will use good faith efforts to incorporate an EEO clause into each union agreement to the end that such union will be contractually bound to refer applicants without regard to their race, color, religion, sex, national origin, age or disability.

c. The contractor is to obtain information as to the referral practices and policies of the labor union except that to the extent such information is within the exclusive possession of the labor union and such labor union refuses to furnish such information to the contractor, the contractor shall so certify to the contracting agency and shall set forth what efforts have been made to obtain such information.

d. In the event the union is unable to provide the contractor with a reasonable flow of referrals within the time limit set forth in the collective bargaining agreement, the contractor will, through independent recruitment efforts, fill the employment vacancies without regard to race, color, religion, sex, national origin, age or disability; making full efforts to obtain qualified and/or qualifiable minorities and women. The failure of a union to provide sufficient referrals (even though it is obligated to provide exclusive referrals under the terms of a collective bargaining agreement) does not relieve the contractor from the requirements of this paragraph. In the event the union referral practice prevents the contractor from meeting the obligations pursuant to Executive Order 11246, as amended, and these special provisions, such contractor shall immediately notify the contracting agency.

**8. Reasonable Accommodation for Applicants / Employees with Disabilities:** The contractor must be familiar

with the requirements for and comply with the Americans with Disabilities Act and all rules and regulations established there under. Employers must provide reasonable accommodation in all employment activities unless to do so would cause an undue hardship.

**9. Selection of Subcontractors, Procurement of Materials and Leasing of Equipment:** The contractor shall not discriminate on the grounds of race, color, religion, sex, national origin, age or disability in the selection and retention of subcontractors, including procurement of materials and leases of equipment. The contractor shall take all necessary and reasonable steps to ensure nondiscrimination in the administration of this contract.

a. The contractor shall notify all potential subcontractors and suppliers and lessors of their EEO obligations under this contract.

b. The contractor will use good faith efforts to ensure subcontractor compliance with their EEO obligations.

**10. Assurance Required by 49 CFR 26.13(b):**

a. The requirements of 49 CFR Part 26 and the State DOT's U.S. DOT-approved DBE program are incorporated by reference.

b. The contractor or subcontractor shall not discriminate on the basis of race, color, national origin, or sex in the performance of this contract. The contractor shall carry out applicable requirements of 49 CFR Part 26 in the award and administration of DOT-assisted contracts. Failure by the contractor to carry out these requirements is a material breach of this contract, which may result in the termination of this contract or such other remedy as the contracting agency deems appropriate.

**11. Records and Reports:** The contractor shall keep such records as necessary to document compliance with the EEO requirements. Such records shall be retained for a period of three years following the date of the final payment to the contractor for all contract work and shall be available at reasonable times and places for inspection by authorized representatives of the contracting agency and the FHWA.

a. The records kept by the contractor shall document the following:

(1) The number and work hours of minority and non-minority group members and women employed in each work classification on the project;

(2) The progress and efforts being made in cooperation with unions, when applicable, to increase employment opportunities for minorities and women; and

(3) The progress and efforts being made in locating, hiring, training, qualifying, and upgrading minorities and women;

b. The contractors and subcontractors will submit an annual report to the contracting agency each July for the duration of the project, indicating the number of minority, women, and non-minority group employees currently engaged in each work classification required by the contract work. This information is to be reported on [Form FHWA-1391](#). The staffing data should represent the project work force on board in all or any part of the last payroll period preceding the end of July. If on-the-job training is being required by special provision, the contractor

will be required to collect and report training data. The employment data should reflect the work force on board during all or any part of the last payroll period preceding the end of July.

### III. NONSEGREGATED FACILITIES

This provision is applicable to all Federal-aid construction contracts and to all related construction subcontracts of \$10,000 or more.

The contractor must ensure that facilities provided for employees are provided in such a manner that segregation on the basis of race, color, religion, sex, or national origin cannot result. The contractor may neither require such segregated use by written or oral policies nor tolerate such use by employee custom. The contractor's obligation extends further to ensure that its employees are not assigned to perform their services at any location, under the contractor's control, where the facilities are segregated. The term "facilities" includes waiting rooms, work areas, restaurants and other eating areas, time clocks, restrooms, washrooms, locker rooms, and other storage or dressing areas, parking lots, drinking fountains, recreation or entertainment areas, transportation, and housing provided for employees. The contractor shall provide separate or single-user restrooms and necessary dressing or sleeping areas to assure privacy between sexes.

### IV. DAVIS-BACON AND RELATED ACT PROVISIONS

This section is applicable to all Federal-aid construction projects exceeding \$2,000 and to all related subcontracts and lower-tier subcontracts (regardless of subcontract size). The requirements apply to all projects located within the right-of-way of a roadway that is functionally classified as Federal-aid highway. This excludes roadways functionally classified as local roads or rural minor collectors, which are exempt. Contracting agencies may elect to apply these requirements to other projects.

The following provisions are from the U.S. Department of Labor regulations in 29 CFR 5.5 "Contract provisions and related matters" with minor revisions to conform to the FHWA-1273 format and FHWA program requirements.

#### 1. Minimum wages

a. All laborers and mechanics employed or working upon the site of the work, will be paid unconditionally and not less often than once a week, and without subsequent deduction or rebate on any account (except such payroll deductions as are permitted by regulations issued by the Secretary of Labor under the Copeland Act (29 CFR part 3)), the full amount of wages and bona fide fringe benefits (or cash equivalents thereof) due at time of payment computed at rates not less than those contained in the wage determination of the Secretary of Labor which is attached hereto and made a part hereof, regardless of any contractual relationship which may be alleged to exist between the contractor and such laborers and mechanics.

Contributions made or costs reasonably anticipated for bona fide fringe benefits under section 1(b)(2) of the Davis-Bacon Act on behalf of laborers or mechanics are considered wages paid to such laborers or mechanics, subject to the provisions

of paragraph 1.d. of this section; also, regular contributions made or costs incurred for more than a weekly period (but not less often than quarterly) under plans, funds, or programs which cover the particular weekly period, are deemed to be constructively made or incurred during such weekly period. Such laborers and mechanics shall be paid the appropriate wage rate and fringe benefits on the wage determination for the classification of work actually performed, without regard to skill, except as provided in 29 CFR 5.5(a)(4). Laborers or mechanics performing work in more than one classification may be compensated at the rate specified for each classification for the time actually worked therein: Provided, That the employer's payroll records accurately set forth the time spent in each classification in which work is performed. The wage determination (including any additional classification and wage rates conformed under paragraph 1.b. of this section) and the Davis-Bacon poster (WH-1321) shall be posted at all times by the contractor and its subcontractors at the site of the work in a prominent and accessible place where it can be easily seen by the workers.

b.(1) The contracting officer shall require that any class of laborers or mechanics, including helpers, which is not listed in the wage determination and which is to be employed under the contract shall be classified in conformance with the wage determination. The contracting officer shall approve an additional classification and wage rate and fringe benefits therefore only when the following criteria have been met:

(i) The work to be performed by the classification requested is not performed by a classification in the wage determination; and

(ii) The classification is utilized in the area by the construction industry; and

(iii) The proposed wage rate, including any bona fide fringe benefits, bears a reasonable relationship to the wage rates contained in the wage determination.

(2) If the contractor and the laborers and mechanics to be employed in the classification (if known), or their representatives, and the contracting officer agree on the classification and wage rate (including the amount designated for fringe benefits where appropriate), a report of the action taken shall be sent by the contracting officer to the Administrator of the Wage and Hour Division, Employment Standards Administration, U.S. Department of Labor, Washington, DC 20210. The Administrator, or an authorized representative, will approve, modify, or disapprove every additional classification action within 30 days of receipt and so advise the contracting officer or will notify the contracting officer within the 30-day period that additional time is necessary.

(3) In the event the contractor, the laborers or mechanics to be employed in the classification or their representatives, and the contracting officer do not agree on the proposed classification and wage rate (including the amount designated for fringe benefits, where appropriate), the contracting officer shall refer the questions, including the views of all interested parties and the recommendation of the contracting officer, to the Wage and Hour Administrator for determination. The Wage and Hour Administrator, or an authorized representative, will issue a determination within 30 days of receipt and so advise the contracting officer or

will notify the contracting officer within the 30-day period that additional time is necessary.

(4) The wage rate (including fringe benefits where appropriate) determined pursuant to paragraphs 1.b.(2) or 1.b.(3) of this section, shall be paid to all workers performing work in the classification under this contract from the first day on which work is performed in the classification.

c. Whenever the minimum wage rate prescribed in the contract for a class of laborers or mechanics includes a fringe benefit which is not expressed as an hourly rate, the contractor shall either pay the benefit as stated in the wage determination or shall pay another bona fide fringe benefit or an hourly cash equivalent thereof.

d. If the contractor does not make payments to a trustee or other third person, the contractor may consider as part of the wages of any laborer or mechanic the amount of any costs reasonably anticipated in providing bona fide fringe benefits under a plan or program. Provided, That the Secretary of Labor has found, upon the written request of the contractor, that the applicable standards of the Davis-Bacon Act have been met. The Secretary of Labor may require the contractor to set aside in a separate account assets for the meeting of obligations under the plan or program.

## 2. Withholding

The contracting agency shall upon its own action or upon written request of an authorized representative of the Department of Labor, withhold or cause to be withheld from the contractor under this contract, or any other Federal contract with the same prime contractor, or any other federally-assisted contract subject to Davis-Bacon prevailing wage requirements, which is held by the same prime contractor, so much of the accrued payments or advances as may be considered necessary to pay laborers and mechanics, including apprentices, trainees, and helpers, employed by the contractor or any subcontractor the full amount of wages required by the contract. In the event of failure to pay any laborer or mechanic, including any apprentice, trainee, or helper, employed or working on the site of the work, all or part of the wages required by the contract, the contracting agency may, after written notice to the contractor, take such action as may be necessary to cause the suspension of any further payment, advance, or guarantee of funds until such violations have ceased.

## 3. Payrolls and basic records

a. Payrolls and basic records relating thereto shall be maintained by the contractor during the course of the work and preserved for a period of three years thereafter for all laborers and mechanics working at the site of the work. Such records shall contain the name, address, and social security number of each such worker, his or her correct classification, hourly rates of wages paid (including rates of contributions or costs anticipated for bona fide fringe benefits or cash equivalents thereof of the types described in section 1(b)(2)(B) of the Davis-Bacon Act), daily and weekly number of hours worked, deductions made and actual wages paid. Whenever the Secretary of Labor has found under 29 CFR 5.5(a)(1)(iv) that the wages of any laborer or mechanic include the amount of any costs reasonably anticipated in providing benefits under a plan or program described in section 1(b)(2)(B) of the Davis-

Bacon Act, the contractor shall maintain records which show that the commitment to provide such benefits is enforceable, that the plan or program is financially responsible, and that the plan or program has been communicated in writing to the laborers or mechanics affected, and records which show the costs anticipated or the actual cost incurred in providing such benefits. Contractors employing apprentices or trainees under approved programs shall maintain written evidence of the registration of apprenticeship programs and certification of trainee programs, the registration of the apprentices and trainees, and the ratios and wage rates prescribed in the applicable programs.

b.(1) The contractor shall submit weekly for each week in which any contract work is performed a copy of all payrolls to the contracting agency. The payrolls submitted shall set out accurately and completely all of the information required to be maintained under 29 CFR 5.5(a)(3)(i), except that full social security numbers and home addresses shall not be included on weekly transmittals. Instead the payrolls shall only need to include an individually identifying number for each employee (e.g., the last four digits of the employee's social security number). The required weekly payroll information may be submitted in any form desired. Optional Form WH-347 is available for this purpose from the Wage and Hour Division Web site at <http://www.dol.gov/esa/whd/forms/wh347instr.htm> or its successor site. The prime contractor is responsible for the submission of copies of payrolls by all subcontractors. Contractors and subcontractors shall maintain the full social security number and current address of each covered worker, and shall provide them upon request to the contracting agency for transmission to the State DOT, the FHWA or the Wage and Hour Division of the Department of Labor for purposes of an investigation or audit of compliance with prevailing wage requirements. It is not a violation of this section for a prime contractor to require a subcontractor to provide addresses and social security numbers to the prime contractor for its own records, without weekly submission to the contracting agency..

(2) Each payroll submitted shall be accompanied by a "Statement of Compliance," signed by the contractor or subcontractor or his or her agent who pays or supervises the payment of the persons employed under the contract and shall certify the following:

(i) That the payroll for the payroll period contains the information required to be provided under §5.5 (a)(3)(ii) of Regulations, 29 CFR part 5, the appropriate information is being maintained under §5.5 (a)(3)(i) of Regulations, 29 CFR part 5, and that such information is correct and complete;

(ii) That each laborer or mechanic (including each helper, apprentice, and trainee) employed on the contract during the payroll period has been paid the full weekly wages earned, without rebate, either directly or indirectly, and that no deductions have been made either directly or indirectly from the full wages earned, other than permissible deductions as set forth in Regulations, 29 CFR part 3;

(iii) That each laborer or mechanic has been paid not less than the applicable wage rates and fringe benefits or cash equivalents for the classification of work performed, as specified in the applicable wage determination incorporated into the contract.

(3) The weekly submission of a properly executed certification set forth on the reverse side of Optional Form WH-347 shall satisfy the requirement for submission of the "Statement of Compliance" required by paragraph 3.b.(2) of this section.

(4) The falsification of any of the above certifications may subject the contractor or subcontractor to civil or criminal prosecution under section 1001 of title 18 and section 231 of title 31 of the United States Code.

c. The contractor or subcontractor shall make the records required under paragraph 3.a. of this section available for inspection, copying, or transcription by authorized representatives of the contracting agency, the State DOT, the FHWA, or the Department of Labor, and shall permit such representatives to interview employees during working hours on the job. If the contractor or subcontractor fails to submit the required records or to make them available, the FHWA may, after written notice to the contractor, the contracting agency or the State DOT, take such action as may be necessary to cause the suspension of any further payment, advance, or guarantee of funds. Furthermore, failure to submit the required records upon request or to make such records available may be grounds for debarment action pursuant to 29 CFR 5.12.

#### 4. Apprentices and trainees

##### a. Apprentices (programs of the USDOL).

Apprentices will be permitted to work at less than the predetermined rate for the work they performed when they are employed pursuant to and individually registered in a bona fide apprenticeship program registered with the U.S. Department of Labor, Employment and Training Administration, Office of Apprenticeship Training, Employer and Labor Services, or with a State Apprenticeship Agency recognized by the Office, or if a person is employed in his or her first 90 days of probationary employment as an apprentice in such an apprenticeship program, who is not individually registered in the program, but who has been certified by the Office of Apprenticeship Training, Employer and Labor Services or a State Apprenticeship Agency (where appropriate) to be eligible for probationary employment as an apprentice.

The allowable ratio of apprentices to journeymen on the job site in any craft classification shall not be greater than the ratio permitted to the contractor as to the entire work force under the registered program. Any worker listed on a payroll at an apprentice wage rate, who is not registered or otherwise employed as stated above, shall be paid not less than the applicable wage rate on the wage determination for the classification of work actually performed. In addition, any apprentice performing work on the job site in excess of the ratio permitted under the registered program shall be paid not less than the applicable wage rate on the wage determination for the work actually performed. Where a contractor is performing construction on a project in a locality other than that in which its program is registered, the ratios and wage rates (expressed in percentages of the journeyman's hourly rate) specified in the contractor's or subcontractor's registered program shall be observed.

Every apprentice must be paid at not less than the rate specified in the registered program for the apprentice's level of progress, expressed as a percentage of the journeymen hourly

rate specified in the applicable wage determination. Apprentices shall be paid fringe benefits in accordance with the provisions of the apprenticeship program. If the apprenticeship program does not specify fringe benefits, apprentices must be paid the full amount of fringe benefits listed on the wage determination for the applicable classification. If the Administrator determines that a different practice prevails for the applicable apprentice classification, fringes shall be paid in accordance with that determination.

In the event the Office of Apprenticeship Training, Employer and Labor Services, or a State Apprenticeship Agency recognized by the Office, withdraws approval of an apprenticeship program, the contractor will no longer be permitted to utilize apprentices at less than the applicable predetermined rate for the work performed until an acceptable program is approved.

##### b. Trainees (programs of the USDOL).

Except as provided in 29 CFR 5.16, trainees will not be permitted to work at less than the predetermined rate for the work performed unless they are employed pursuant to and individually registered in a program which has received prior approval, evidenced by formal certification by the U.S. Department of Labor, Employment and Training Administration.

The ratio of trainees to journeymen on the job site shall not be greater than permitted under the plan approved by the Employment and Training Administration.

Every trainee must be paid at not less than the rate specified in the approved program for the trainee's level of progress, expressed as a percentage of the journeyman hourly rate specified in the applicable wage determination. Trainees shall be paid fringe benefits in accordance with the provisions of the trainee program. If the trainee program does not mention fringe benefits, trainees shall be paid the full amount of fringe benefits listed on the wage determination unless the Administrator of the Wage and Hour Division determines that there is an apprenticeship program associated with the corresponding journeyman wage rate on the wage determination which provides for less than full fringe benefits for apprentices. Any employee listed on the payroll at a trainee rate who is not registered and participating in a training plan approved by the Employment and Training Administration shall be paid not less than the applicable wage rate on the wage determination for the classification of work actually performed. In addition, any trainee performing work on the job site in excess of the ratio permitted under the registered program shall be paid not less than the applicable wage rate on the wage determination for the work actually performed.

In the event the Employment and Training Administration withdraws approval of a training program, the contractor will no longer be permitted to utilize trainees at less than the applicable predetermined rate for the work performed until an acceptable program is approved.

c. Equal employment opportunity. The utilization of apprentices, trainees and journeymen under this part shall be in conformity with the equal employment opportunity requirements of Executive Order 11246, as amended, and 29 CFR part 30.

d. Apprentices and Trainees (programs of the U.S. DOT).

Apprentices and trainees working under apprenticeship and skill training programs which have been certified by the Secretary of Transportation as promoting EEO in connection with Federal-aid highway construction programs are not subject to the requirements of paragraph 4 of this Section IV. The straight time hourly wage rates for apprentices and trainees under such programs will be established by the particular programs. The ratio of apprentices and trainees to journeymen shall not be greater than permitted by the terms of the particular program.

**5. Compliance with Copeland Act requirements.** The contractor shall comply with the requirements of 29 CFR part 3, which are incorporated by reference in this contract.

**6. Subcontracts.** The contractor or subcontractor shall insert Form FHWA-1273 in any subcontracts and also require the subcontractors to include Form FHWA-1273 in any lower tier subcontracts. The prime contractor shall be responsible for the compliance by any subcontractor or lower tier subcontractor with all the contract clauses in 29 CFR 5.5.

**7. Contract termination: debarment.** A breach of the contract clauses in 29 CFR 5.5 may be grounds for termination of the contract, and for debarment as a contractor and a subcontractor as provided in 29 CFR 5.12.

**8. Compliance with Davis-Bacon and Related Act requirements.** All rulings and interpretations of the Davis-Bacon and Related Acts contained in 29 CFR parts 1, 3, and 5 are herein incorporated by reference in this contract.

**9. Disputes concerning labor standards.** Disputes arising out of the labor standards provisions of this contract shall not be subject to the general disputes clause of this contract. Such disputes shall be resolved in accordance with the procedures of the Department of Labor set forth in 29 CFR parts 5, 6, and 7. Disputes within the meaning of this clause include disputes between the contractor (or any of its subcontractors) and the contracting agency, the U.S. Department of Labor, or the employees or their representatives.

**10. Certification of eligibility.**

a. By entering into this contract, the contractor certifies that neither it (nor he or she) nor any person or firm who has an interest in the contractor's firm is a person or firm ineligible to be awarded Government contracts by virtue of section 3(a) of the Davis-Bacon Act or 29 CFR 5.12(a)(1).

b. No part of this contract shall be subcontracted to any person or firm ineligible for award of a Government contract by virtue of section 3(a) of the Davis-Bacon Act or 29 CFR 5.12(a)(1).

c. The penalty for making false statements is prescribed in the U.S. Criminal Code, 18 U.S.C. 1001.

**V. CONTRACT WORK HOURS AND SAFETY STANDARDS ACT**

The following clauses apply to any Federal-aid construction contract in an amount in excess of \$100,000 and subject to the overtime provisions of the Contract Work Hours and Safety Standards Act. These clauses shall be inserted in addition to the clauses required by 29 CFR 5.5(a) or 29 CFR 4.6. As used in this paragraph, the terms laborers and mechanics include watchmen and guards.

**1. Overtime requirements.** No contractor or subcontractor contracting for any part of the contract work which may require or involve the employment of laborers or mechanics shall require or permit any such laborer or mechanic in any workweek in which he or she is employed on such work to work in excess of forty hours in such workweek unless such laborer or mechanic receives compensation at a rate not less than one and one-half times the basic rate of pay for all hours worked in excess of forty hours in such workweek.

**2. Violation; liability for unpaid wages; liquidated damages.** In the event of any violation of the clause set forth in paragraph (1.) of this section, the contractor and any subcontractor responsible therefor shall be liable for the unpaid wages. In addition, such contractor and subcontractor shall be liable to the United States (in the case of work done under contract for the District of Columbia or a territory, to such District or to such territory), for liquidated damages. Such liquidated damages shall be computed with respect to each individual laborer or mechanic, including watchmen and guards, employed in violation of the clause set forth in paragraph (1.) of this section, in the sum of \$10 for each calendar day on which such individual was required or permitted to work in excess of the standard workweek of forty hours without payment of the overtime wages required by the clause set forth in paragraph (1.) of this section.

**3. Withholding for unpaid wages and liquidated damages.** The FHWA or the contracting agency shall upon its own action or upon written request of an authorized representative of the Department of Labor withhold or cause to be withheld, from any moneys payable on account of work performed by the contractor or subcontractor under any such contract or any other Federal contract with the same prime contractor, or any other federally-assisted contract subject to the Contract Work Hours and Safety Standards Act, which is held by the same prime contractor, such sums as may be determined to be necessary to satisfy any liabilities of such contractor or subcontractor for unpaid wages and liquidated damages as provided in the clause set forth in paragraph (2.) of this section.

**4. Subcontracts.** The contractor or subcontractor shall insert in any subcontracts the clauses set forth in paragraph (1.) through (4.) of this section and also a clause requiring the subcontractors to include these clauses in any lower tier subcontracts. The prime contractor shall be responsible for compliance by any subcontractor or lower tier subcontractor with the clauses set forth in paragraphs (1.) through (4.) of this section.

## VI. SUBLETTING OR ASSIGNING THE CONTRACT

This provision is applicable to all Federal-aid construction contracts on the National Highway System.

1. The contractor shall perform with its own organization contract work amounting to not less than 30 percent (or a greater percentage if specified elsewhere in the contract) of the total original contract price, excluding any specialty items designated by the contracting agency. Specialty items may be performed by subcontract and the amount of any such specialty items performed may be deducted from the total original contract price before computing the amount of work required to be performed by the contractor's own organization (23 CFR 635.116).

a. The term "perform work with its own organization" refers to workers employed or leased by the prime contractor, and equipment owned or rented by the prime contractor, with or without operators. Such term does not include employees or equipment of a subcontractor or lower tier subcontractor, agents of the prime contractor, or any other assignees. The term may include payments for the costs of hiring leased employees from an employee leasing firm meeting all relevant Federal and State regulatory requirements. Leased employees may only be included in this term if the prime contractor meets all of the following conditions:

- (1) the prime contractor maintains control over the supervision of the day-to-day activities of the leased employees;
- (2) the prime contractor remains responsible for the quality of the work of the leased employees;
- (3) the prime contractor retains all power to accept or exclude individual employees from work on the project; and
- (4) the prime contractor remains ultimately responsible for the payment of predetermined minimum wages, the submission of payrolls, statements of compliance and all other Federal regulatory requirements.

b. "Specialty Items" shall be construed to be limited to work that requires highly specialized knowledge, abilities, or equipment not ordinarily available in the type of contracting organizations qualified and expected to bid or propose on the contract as a whole and in general are to be limited to minor components of the overall contract.

2. The contract amount upon which the requirements set forth in paragraph (1) of Section VI is computed includes the cost of material and manufactured products which are to be purchased or produced by the contractor under the contract provisions.

3. The contractor shall furnish (a) a competent superintendent or supervisor who is employed by the firm, has full authority to direct performance of the work in accordance with the contract requirements, and is in charge of all construction operations (regardless of who performs the work) and (b) such other of its own organizational resources (supervision, management, and engineering services) as the contracting officer determines is necessary to assure the performance of the contract.

4. No portion of the contract shall be sublet, assigned or otherwise disposed of except with the written consent of the contracting officer, or authorized representative, and such consent when given shall not be construed to relieve the contractor of any responsibility for the fulfillment of the contract. Written consent will be given only after the contracting agency has assured that each subcontract is

evidenced in writing and that it contains all pertinent provisions and requirements of the prime contract.

5. The 30% self-performance requirement of paragraph (1) is not applicable to design-build contracts; however, contracting agencies may establish their own self-performance requirements.

## VII. SAFETY: ACCIDENT PREVENTION

This provision is applicable to all Federal-aid construction contracts and to all related subcontracts.

1. In the performance of this contract the contractor shall comply with all applicable Federal, State, and local laws governing safety, health, and sanitation (23 CFR 635). The contractor shall provide all safeguards, safety devices and protective equipment and take any other needed actions as it determines, or as the contracting officer may determine, to be reasonably necessary to protect the life and health of employees on the job and the safety of the public and to protect property in connection with the performance of the work covered by the contract.

2. It is a condition of this contract, and shall be made a condition of each subcontract, which the contractor enters into pursuant to this contract, that the contractor and any subcontractor shall not permit any employee, in performance of the contract, to work in surroundings or under conditions which are unsanitary, hazardous or dangerous to his/her health or safety, as determined under construction safety and health standards (29 CFR 1926) promulgated by the Secretary of Labor, in accordance with Section 107 of the Contract Work Hours and Safety Standards Act (40 U.S.C. 3704).

3. Pursuant to 29 CFR 1926.3, it is a condition of this contract that the Secretary of Labor or authorized representative thereof, shall have right of entry to any site of contract performance to inspect or investigate the matter of compliance with the construction safety and health standards and to carry out the duties of the Secretary under Section 107 of the Contract Work Hours and Safety Standards Act (40 U.S.C.3704).

## VIII. FALSE STATEMENTS CONCERNING HIGHWAY PROJECTS

This provision is applicable to all Federal-aid construction contracts and to all related subcontracts.

In order to assure high quality and durable construction in conformity with approved plans and specifications and a high degree of reliability on statements and representations made by engineers, contractors, suppliers, and workers on Federal-aid highway projects, it is essential that all persons concerned with the project perform their functions as carefully, thoroughly, and honestly as possible. Willful falsification, distortion, or misrepresentation with respect to any facts related to the project is a violation of Federal law. To prevent any misunderstanding regarding the seriousness of these and similar acts, Form FHWA-1022 shall be posted on each Federal-aid highway project (23 CFR 635) in one or more places where it is readily available to all persons concerned with the project:

18 U.S.C. 1020 reads as follows:

"Whoever, being an officer, agent, or employee of the United States, or of any State or Territory, or whoever, whether a person, association, firm, or corporation, knowingly makes any false statement, false representation, or false report as to the character, quality, quantity, or cost of the material used or to be used, or the quantity or quality of the work performed or to be performed, or the cost thereof in connection with the submission of plans, maps, specifications, contracts, or costs of construction on any highway or related project submitted for approval to the Secretary of Transportation; or

Whoever knowingly makes any false statement, false representation, false report or false claim with respect to the character, quality, quantity, or cost of any work performed or to be performed, or materials furnished or to be furnished, in connection with the construction of any highway or related project approved by the Secretary of Transportation; or

Whoever knowingly makes any false statement or false representation as to material fact in any statement, certificate, or report submitted pursuant to provisions of the Federal-aid Roads Act approved July 1, 1916, (39 Stat. 355), as amended and supplemented;

Shall be fined under this title or imprisoned not more than 5 years or both."

#### **IX. IMPLEMENTATION OF CLEAN AIR ACT AND FEDERAL WATER POLLUTION CONTROL ACT**

This provision is applicable to all Federal-aid construction contracts and to all related subcontracts.

By submission of this bid/proposal or the execution of this contract, or subcontract, as appropriate, the bidder, proposer, Federal-aid construction contractor, or subcontractor, as appropriate, will be deemed to have stipulated as follows:

1. That any person who is or will be utilized in the performance of this contract is not prohibited from receiving an award due to a violation of Section 508 of the Clean Water Act or Section 306 of the Clean Air Act.

2. That the contractor agrees to include or cause to be included the requirements of paragraph (1) of this Section X in every subcontract, and further agrees to take such action as the contracting agency may direct as a means of enforcing such requirements.

#### **X. CERTIFICATION REGARDING DEBARMENT, SUSPENSION, INELIGIBILITY AND VOLUNTARY EXCLUSION**

This provision is applicable to all Federal-aid construction contracts, design-build contracts, subcontracts, lower-tier subcontracts, purchase orders, lease agreements, consultant contracts or any other covered transaction requiring FHWA approval or that is estimated to cost \$25,000 or more – as defined in 2 CFR Parts 180 and 1200.

##### **1. Instructions for Certification – First Tier Participants:**

a. By signing and submitting this proposal, the prospective first tier participant is providing the certification set out below.

b. The inability of a person to provide the certification set out below will not necessarily result in denial of participation in this

covered transaction. The prospective first tier participant shall submit an explanation of why it cannot provide the certification set out below. The certification or explanation will be considered in connection with the department or agency's determination whether to enter into this transaction. However, failure of the prospective first tier participant to furnish a certification or an explanation shall disqualify such a person from participation in this transaction.

c. The certification in this clause is a material representation of fact upon which reliance was placed when the contracting agency determined to enter into this transaction. If it is later determined that the prospective participant knowingly rendered an erroneous certification, in addition to other remedies available to the Federal Government, the contracting agency may terminate this transaction for cause of default.

d. The prospective first tier participant shall provide immediate written notice to the contracting agency to whom this proposal is submitted if any time the prospective first tier participant learns that its certification was erroneous when submitted or has become erroneous by reason of changed circumstances.

e. The terms "covered transaction," "debarred," "suspended," "ineligible," "participant," "person," "principal," and "voluntarily excluded," as used in this clause, are defined in 2 CFR Parts 180 and 1200. "First Tier Covered Transactions" refers to any covered transaction between a grantee or subgrantee of Federal funds and a participant (such as the prime or general contract). "Lower Tier Covered Transactions" refers to any covered transaction under a First Tier Covered Transaction (such as subcontracts). "First Tier Participant" refers to the participant who has entered into a covered transaction with a grantee or subgrantee of Federal funds (such as the prime or general contractor). "Lower Tier Participant" refers any participant who has entered into a covered transaction with a First Tier Participant or other Lower Tier Participants (such as subcontractors and suppliers).

f. The prospective first tier participant agrees by submitting this proposal that, should the proposed covered transaction be entered into, it shall not knowingly enter into any lower tier covered transaction with a person who is debarred, suspended, declared ineligible, or voluntarily excluded from participation in this covered transaction, unless authorized by the department or agency entering into this transaction.

g. The prospective first tier participant further agrees by submitting this proposal that it will include the clause titled "Certification Regarding Debarment, Suspension, Ineligibility and Voluntary Exclusion-Lower Tier Covered Transactions," provided by the department or contracting agency, entering into this covered transaction, without modification, in all lower tier covered transactions and in all solicitations for lower tier covered transactions exceeding the \$25,000 threshold.

h. A participant in a covered transaction may rely upon a certification of a prospective participant in a lower tier covered transaction that is not debarred, suspended, ineligible, or voluntarily excluded from the covered transaction, unless it knows that the certification is erroneous. A participant is responsible for ensuring that its principals are not suspended, debarred, or otherwise ineligible to participate in covered transactions. To verify the eligibility of its principals, as well as the eligibility of any lower tier prospective participants, each participant may, but is not required to, check the Excluded Parties List System website (<https://www.epls.gov/>), which is compiled by the General Services Administration.



i. Nothing contained in the foregoing shall be construed to require the establishment of a system of records in order to render in good faith the certification required by this clause. The knowledge and information of the prospective participant is not required to exceed that which is normally possessed by a prudent person in the ordinary course of business dealings.

j. Except for transactions authorized under paragraph (f) of these instructions, if a participant in a covered transaction knowingly enters into a lower tier covered transaction with a person who is suspended, debarred, ineligible, or voluntarily excluded from participation in this transaction, in addition to other remedies available to the Federal Government, the department or agency may terminate this transaction for cause or default.

\* \* \* \* \*

## **2. Certification Regarding Debarment, Suspension, Ineligibility and Voluntary Exclusion – First Tier Participants:**

a. The prospective first tier participant certifies to the best of its knowledge and belief, that it and its principals:

(1) Are not presently debarred, suspended, proposed for debarment, declared ineligible, or voluntarily excluded from participating in covered transactions by any Federal department or agency;

(2) Have not within a three-year period preceding this proposal been convicted of or had a civil judgment rendered against them for commission of fraud or a criminal offense in connection with obtaining, attempting to obtain, or performing a public (Federal, State or local) transaction or contract under a public transaction; violation of Federal or State antitrust statutes or commission of embezzlement, theft, forgery, bribery, falsification or destruction of records, making false statements, or receiving stolen property;

(3) Are not presently indicted for or otherwise criminally or civilly charged by a governmental entity (Federal, State or local) with commission of any of the offenses enumerated in paragraph (a)(2) of this certification; and

(4) Have not within a three-year period preceding this application/proposal had one or more public transactions (Federal, State or local) terminated for cause or default.

b. Where the prospective participant is unable to certify to any of the statements in this certification, such prospective participant shall attach an explanation to this proposal.

### **2. Instructions for Certification - Lower Tier Participants:**

(Applicable to all subcontracts, purchase orders and other lower tier transactions requiring prior FHWA approval or estimated to cost \$25,000 or more - 2 CFR Parts 180 and 1200)

a. By signing and submitting this proposal, the prospective lower tier is providing the certification set out below.

b. The certification in this clause is a material representation of fact upon which reliance was placed when this transaction was entered into. If it is later determined that the prospective lower tier participant knowingly rendered an erroneous certification, in addition to other remedies available to the Federal Government, the department, or agency with which

this transaction originated may pursue available remedies, including suspension and/or debarment.

c. The prospective lower tier participant shall provide immediate written notice to the person to which this proposal is submitted if at any time the prospective lower tier participant learns that its certification was erroneous by reason of changed circumstances.

d. The terms "covered transaction," "debarred," "suspended," "ineligible," "participant," "person," "principal," and "voluntarily excluded," as used in this clause, are defined in 2 CFR Parts 180 and 1200. You may contact the person to which this proposal is submitted for assistance in obtaining a copy of those regulations. "First Tier Covered Transactions" refers to any covered transaction between a grantee or subgrantee of Federal funds and a participant (such as the prime or general contract). "Lower Tier Covered Transactions" refers to any covered transaction under a First Tier Covered Transaction (such as subcontracts). "First Tier Participant" refers to the participant who has entered into a covered transaction with a grantee or subgrantee of Federal funds (such as the prime or general contractor). "Lower Tier Participant" refers any participant who has entered into a covered transaction with a First Tier Participant or other Lower Tier Participants (such as subcontractors and suppliers).

e. The prospective lower tier participant agrees by submitting this proposal that, should the proposed covered transaction be entered into, it shall not knowingly enter into any lower tier covered transaction with a person who is debarred, suspended, declared ineligible, or voluntarily excluded from participation in this covered transaction, unless authorized by the department or agency with which this transaction originated.

f. The prospective lower tier participant further agrees by submitting this proposal that it will include this clause titled "Certification Regarding Debarment, Suspension, Ineligibility and Voluntary Exclusion-Lower Tier Covered Transaction," without modification, in all lower tier covered transactions and in all solicitations for lower tier covered transactions exceeding the \$25,000 threshold.

g. A participant in a covered transaction may rely upon a certification of a prospective participant in a lower tier covered transaction that is not debarred, suspended, ineligible, or voluntarily excluded from the covered transaction, unless it knows that the certification is erroneous. A participant is responsible for ensuring that its principals are not suspended, debarred, or otherwise ineligible to participate in covered transactions. To verify the eligibility of its principals, as well as the eligibility of any lower tier prospective participants, each participant may, but is not required to, check the Excluded Parties List System website (<https://www.epls.gov/>), which is compiled by the General Services Administration.

h. Nothing contained in the foregoing shall be construed to require establishment of a system of records in order to render in good faith the certification required by this clause. The knowledge and information of participant is not required to exceed that which is normally possessed by a prudent person in the ordinary course of business dealings.

i. Except for transactions authorized under paragraph e of these instructions, if a participant in a covered transaction knowingly enters into a lower tier covered transaction with a person who is suspended, debarred, ineligible, or voluntarily excluded from participation in this transaction, in addition to other remedies available to the Federal Government, the

department or agency with which this transaction originated may pursue available remedies, including suspension and/or debarment.

\* \* \* \* \*

**Certification Regarding Debarment, Suspension, Ineligibility and Voluntary Exclusion--Lower Tier Participants:**

1. The prospective lower tier participant certifies, by submission of this proposal, that neither it nor its principals is presently debarred, suspended, proposed for debarment, declared ineligible, or voluntarily excluded from participating in covered transactions by any Federal department or agency.

2. Where the prospective lower tier participant is unable to certify to any of the statements in this certification, such prospective participant shall attach an explanation to this proposal.

\* \* \* \* \*

**XI. CERTIFICATION REGARDING USE OF CONTRACT FUNDS FOR LOBBYING**

This provision is applicable to all Federal-aid construction contracts and to all related subcontracts which exceed \$100,000 (49 CFR 20).

1. The prospective participant certifies, by signing and submitting this bid or proposal, to the best of his or her knowledge and belief, that:

a. No Federal appropriated funds have been paid or will be paid, by or on behalf of the undersigned, to any person for influencing or attempting to influence an officer or employee of any Federal agency, a Member of Congress, an officer or employee of Congress, or an employee of a Member of Congress in connection with the awarding of any Federal contract, the making of any Federal grant, the making of any Federal loan, the entering into of any cooperative agreement, and the extension, continuation, renewal, amendment, or modification of any Federal contract, grant, loan, or cooperative agreement.

b. If any funds other than Federal appropriated funds have been paid or will be paid to any person for influencing or attempting to influence an officer or employee of any Federal agency, a Member of Congress, an officer or employee of Congress, or an employee of a Member of Congress in connection with this Federal contract, grant, loan, or cooperative agreement, the undersigned shall complete and submit Standard Form-LLL, "Disclosure Form to Report Lobbying," in accordance with its instructions.

2. This certification is a material representation of fact upon which reliance was placed when this transaction was made or entered into. Submission of this certification is a prerequisite for making or entering into this transaction imposed by 31 U.S.C. 1352. Any person who fails to file the required certification shall be subject to a civil penalty of not less than \$10,000 and not more than \$100,000 for each such failure.

3. The prospective participant also agrees by submitting its bid or proposal that the participant shall require that the language of this certification be included in all lower tier subcontracts, which exceed \$100,000 and that all such recipients shall certify and disclose accordingly.

**ATTACHMENT A - EMPLOYMENT AND MATERIALS PREFERENCE FOR APPALACHIAN DEVELOPMENT HIGHWAY SYSTEM OR APPALACHIAN LOCAL ACCESS ROAD CONTRACTS**

This provision is applicable to all Federal-aid projects funded under the Appalachian Regional Development Act of 1965.

1. During the performance of this contract, the contractor undertaking to do work which is, or reasonably may be, done as on-site work, shall give preference to qualified persons who regularly reside in the labor area as designated by the DOL wherein the contract work is situated, or the subregion, or the Appalachian counties of the State wherein the contract work is situated, except:

a. To the extent that qualified persons regularly residing in the area are not available.

b. For the reasonable needs of the contractor to employ supervisory or specially experienced personnel necessary to assure an efficient execution of the contract work.

c. For the obligation of the contractor to offer employment to present or former employees as the result of a lawful collective bargaining contract, provided that the number of nonresident persons employed under this subparagraph (1c) shall not exceed 20 percent of the total number of employees employed by the contractor on the contract work, except as provided in subparagraph (4) below.

2. The contractor shall place a job order with the State Employment Service indicating (a) the classifications of the laborers, mechanics and other employees required to perform the contract work, (b) the number of employees required in each classification, (c) the date on which the participant estimates such employees will be required, and (d) any other pertinent information required by the State Employment Service to complete the job order form. The job order may be placed with the State Employment Service in writing or by telephone. If during the course of the contract work, the information submitted by the contractor in the original job order is substantially modified, the participant shall promptly notify the State Employment Service.

3. The contractor shall give full consideration to all qualified job applicants referred to him by the State Employment Service. The contractor is not required to grant employment to any job applicants who, in his opinion, are not qualified to perform the classification of work required.

4. If, within one week following the placing of a job order by the contractor with the State Employment Service, the State Employment Service is unable to refer any qualified job applicants to the contractor, or less than the number requested, the State Employment Service will forward a certificate to the contractor indicating the unavailability of applicants. Such certificate shall be made a part of the contractor's permanent project records. Upon receipt of this certificate, the contractor may employ persons who do not normally reside in the labor area to fill positions covered by the certificate, notwithstanding the provisions of subparagraph (1c) above.

5. The provisions of 23 CFR 633.207(e) allow the contracting agency to provide a contractual preference for the use of mineral resource materials native to the Appalachian region.

6. The contractor shall include the provisions of Sections 1 through 4 of this Attachment A in every subcontract for work which is, or reasonably may be, done as on-site work.

# FLORISSANT CITY COUNCIL AGENDA REQUEST FORM

6/21/2022		<b>Mayor's Approval:</b> 	
Agenda Date Requested:	6/27/2022		
Description of request: Agreement with Missouri Highways and Transportation Commission			
Transfer of Funds from (See Attached Memo)			
Department: Public Works			
Recommending Board or Commission: N/A			
Type of request:	<b>Ordinances</b>	<b>X</b>	<b>Other</b>
	Appropriation		Liquor License
	Transfer		Hotel License
	Zoning Amendment		Special Presentations
	Amendment		Resolution
	Special Use Transfer		Proclamation
	Special Use		Subdivision
	Budget Amendment		
Public Hearing needed: Yes / No		Y/N	Y/N
		<b>N</b>	3 readings?: Yes / No
<b>Back up materials attached:</b>		<b>Back up materials needed:</b>	
Minutes		Minutes	
Maps		Maps	
Memo	<b>X</b>	Memo	
Draft Ord.		Draft Ord.	
<p><b>Note:</b> Please include all attachments necessary for documents to be generated for inclusion on the Agenda. All agenda requests are to be turned in to the City Clerk by 5pm on Tuesday prior to the Council meeting.</p>		<p>For City Clerk Use Only:</p> <p>Introduced by: _____</p> <p>PH Speaker: _____</p>	

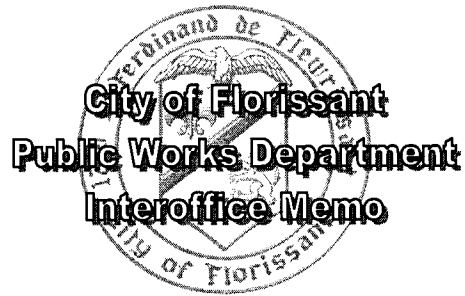

Memo To: City Council

Date: June 22, 2022

Thru: Mayor Timothy J. Lowery

From: Todd M. Hughes, P.E.  
Director of Public Works and Health

Copy: Kimberlee Johnson

Subject: Mullanphy Road Project

I request that the City council allow the Mayor to enter into an agreement with Missouri Highway and Transportation Commission for the purpose of adding sidewalks and resurfacing Mullanphy Road from Patterson Road to Fernbrooke drive. This will be a federal share project where the City will pay 20 % of the Cost of the Project.

**Therefore, I respectfully request the Council allow the Mayor to enter into an agreement with Missouri Highway and Transportation Commission for the Mullanphy Road project .**

Thank you in advance.

Respectfully submitted,

  
\_\_\_\_\_  
Todd M Hughes, P.E.

1 INTRODUCED BY COUNCILMAN EAGAN  
2 JUNE 27, 2022

3  
4 BILL NO. 9796 ORDINANCE NO.

5  
6 **ORDINANCE AUTHORIZING AN APPROPRIATION OF \$150,000 FROM**  
7 **THE SEWER LATERAL FUND TO ACCOUNT NO. 04-5-08-50050**  
8 **“PROFESSIONAL SERVICES SEWER LATERAL REPAIRS” FOR THE**  
9 **INSTALLATION OF CHECK VALVES.**

10  
11 BE IT ORDAINED BY THE COUNCIL OF THE CITY OF FLORISSANT, ST. LOUIS  
12 COUNTY, MISSOURI, AS FOLLOWS:

13  
14  
15 Section 1: There is hereby authorized an appropriation of \$150,000 from the Sewer  
16 Lateral Fund to account no. 04-5-08-50050 “Professional Services Sewer Lateral Repairs” for  
17 the installation of check valves.

18  
19 Section 2: This ordinance shall become in force and effect immediately upon its passage  
20 and approval.

21  
22 Adopted this \_\_\_\_ day of \_\_\_\_\_, 2022.

23  
24 \_\_\_\_\_  
25 Joseph Eagan  
26 President of the Council  
27 City of Florissant

28 Approved this \_\_\_\_ day of \_\_\_\_\_, 2022.

29  
30 \_\_\_\_\_  
31 Timothy J. Lowery  
32 Mayor, City of Florissant

33 ATTEST:  
34  
35 \_\_\_\_\_  
36 Karen Goodwin, MPPA/MMC/MRCC,  
37 City Clerk

# FLORISSANT CITY COUNCIL AGENDA REQUEST FORM

6/22/2022		<b>Mayor's Approval:</b> 		
Agenda Date Requested:	6/27/2022			
Description of request:     Appropriation for MSD Check valve installation				
Transfer of Funds from (See Attached Memo)				
Department: Public Works				
Recommending Board or Commission: N/A				
<b>Type of request:</b>	<b>Ordinances</b>	<b>X</b>	<b>Other</b>	
	Appropriation	<b>x</b>	Liquor License	
	Transfer		Hotel License	
	Zoning Amendment		Special Presentations	
	Amendment		Resolution	
	Special Use Transfer		Proclamation	
	Special Use		Subdivision	
	Budget Amendment			
Public Hearing needed: <b>Yes / No</b>		<b>N</b>	3 readings? : <b>Yes / No</b>	
<b>Back up materials attached:</b>		<b>Back up materials needed:</b>		
Minutes		Minutes		
Maps		Maps		
Memo	<b>X</b>	Memo		
Draft Ord.		Draft Ord.		
<p><b>Note:</b> Please include all attachments necessary for documents to be generated for inclusion on the Agenda. All agenda requests are to be turned in to the City Clerk by 5pm on Tuesday prior to the Council meeting.</p>		<p>For City Clerk Use Only:</p> <p>Introduced by: _____</p> <p>PH Speaker: _____</p>		

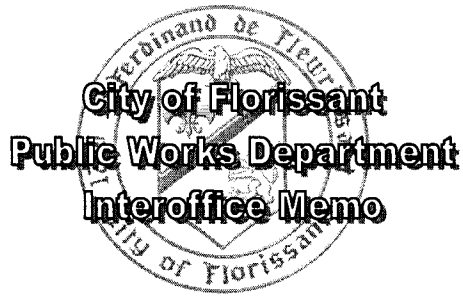

Memo To: City Council

Date: June 22, 2022

Thru: Mayor Timothy J. Lowery

From: Todd M. Hughes, P.E.  
Director of Public Works and Health

Copy: Kimberlee Johnson

Subject: **Appropriation for Sewer Check Valves – Sewer Lateral Fund**

The City entered into an agreement with Metropolitan Sewer District for Sanitary Sewer relief. This project was to install sump pumps and check valves. The City agreed to pay for the installation of the check valves.

**Therefore, I respectfully request that \$150,000 be appropriated from Sewer Lateral Fund to Account 04-5-08-50050 – Professional Services Sewer lateral repairs.**

Thank you in advance.

Respectfully submitted,

  
\_\_\_\_\_  
Todd M. Hughes, P.E.



1 INTRODUCED BY COUNCILMAN EAGAN  
2 JUNE 27, 2022

3  
4 BILL NO. 9797

ORDINANCE NO.

5  
6 **ORDINANCE AUTHORIZING AN APPROPRIATION OF \$23,000 FROM**  
7 **THE GENERAL REVENUE FUND TO ACCOUNT NO. 01-5-40-52150**  
8 **“ELECTION EXPENSE” TO COVER THE AUGUST ELECTION**  
9 **EXPENSES.**

10  
11 BE IT ORDAINED BY THE COUNCIL OF THE CITY OF FLORISSANT, ST. LOUIS  
12 COUNTY, MISSOURI, AS FOLLOWS:

13  
14  
15 Section 1: There is hereby authorized an appropriation of \$23,000 from the General  
16 Revenue Fund to account no. 01-5-40-52150 “Election Expense” to cover the August election  
17 expenses.

18  
19 Section 2: This ordinance shall become in force and effect immediately upon its passage  
20 and approval.

21  
22 Adopted this \_\_\_\_\_ day of \_\_\_\_\_, 2022.

23  
24 \_\_\_\_\_  
25 Joseph Eagan  
26 President of the Council  
27 City of Florissant

28 Approved this \_\_\_\_\_ day of \_\_\_\_\_, 2022.

29  
30 \_\_\_\_\_  
31 Timothy J. Lowery  
32 Mayor, City of Florissant

33 ATTEST:  
34  
35 \_\_\_\_\_  
36 Karen Goodwin, MPPA/MMC/MRCC,  
37 City Clerk

# FLORISSANT CITY COUNCIL

## AGENDA REQUEST FORM

Date: 6/22/2022

Mayor's Approval:

Agenda Date Requested: 6/27/2022

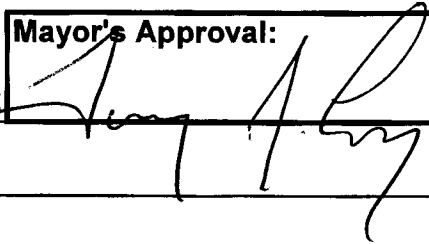

Description of request:

Request for an appropriation from the General Revenue Fund to account no. 01-5-40-52150 "Election Expense" to cover the election expense for the August election.

Department: City Clerk

Recommending Board or Commission:

Type of request:

Ordinances	X	Other	X
Appropriation	x	Liquor License	
Transfer		Hotel License	
Zoning Amendment		Special Presentations	
CD Amendment		Resolution	
Special Use Transfer		Proclamation	
Special Use		Subdivision	
Budget Amendment			

Public Hearing needed: Yes / No

Y/N

3 readings? : Yes / No

Y/N

y

Back up materials attached:		Back up materials needed:	
Minutes		Minutes	
Maps		Maps	
Memo		Memo	
Draft Ord.		Draft Ord.	

**Note:** Please include all attachments necessary for documents to be generated for inclusion on the Agenda. All agenda requests are to be turned in to the City Clerk by 5pm on Tuesday prior to the Council meeting.

For City Clerk Use Only:

Introduced by: \_\_\_\_\_

PH Speaker: \_\_\_\_\_

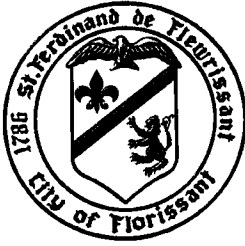

*Memorandum*  
*City of Florissant, Missouri*  
*Office of the City Clerk*



**TO:** Mayor Lowery  
**FROM:** Karen Goodwin, City Clerk  
**SUBJECT:** Election Expense Appropriation request  
**Date:** 6/22/2022

---

---

Since the August 2022 Election for the Aquatic Centers Bond issue was not anticipated at budget time last year, the Election Expense account does not have enough funds to cover the August election. Based on history, the election expense is approximately \$35,000 for a full city election. An appropriation is needed to supplement the balance in the account to cover the anticipated expense.

Therefore, we are requesting an appropriation of \$23,000 from the General Revenue Fund to account no. 01-5-40-52150 "Election Expense" to cover the cost of the August Election.

1 INTRODUCED BY COUNCILMAN EAGAN  
2 JUNE 27, 2022

3  
4 BILL NO. 9798

ORDINANCE NO.

5

6 **ORDINANCE AMENDING CHAPTER 125.065 “WAGE INCREASE**  
7 **AND SCHEDULE”, SECTION B “POLICE DEPARTMENT**  
8 **EMPLOYEES” BY DELETING THE POSITION OF ACADEMY**  
9 **RECRUIT.**

10

11 WHEREAS, the Police Chief recommends that the City utilize a Police Training  
12 Reimbursement Agreement as an incentive to attract and retain Academy Recruits for  
13 employment within the Police Department, and

14

15 WHEREAS, Police Recruits cannot be employees under the Police Training  
16 Reimbursement Agreement.

17

18 **NOW, THEREFORE, BE IT ORDAINED BY THE COUNCIL OF THE CITY OF**  
19 **FLORISSANT, ST. LOUIS COUNTY, MISSOURI, AS FOLLOWS:**

20

21 Section 1: Section 125.065 “Wage Increase and Schedule”, Section B “Police  
22 Department Employees”, subsection 1 “Job Classifications” is hereby amended by deleting the  
23 following:

24

25 Academy Recruit (Police)

26

27 Section 2. Section 125.065 “Wage Increase and Schedule”, Section B “Police  
28 Department Employees”, subsection 5h is hereby deleted in its entirety.

29 Section 3: This ordinance shall become in force and effect immediately upon its passage  
30 and approval.

31

32 Adopted this \_\_\_\_ day of \_\_\_\_\_, 2022.

33

34 \_\_\_\_\_  
35 Joseph Eagan, Council President

36

37 Approved this \_\_\_\_ day of \_\_\_\_\_, 2022.

38

39 \_\_\_\_\_  
40 Timothy J. Lowery, Mayor

41

42 ATTEST:  
43 \_\_\_\_\_  
44 Karen Goodwin, MPPA/MMC/MRCC  
City Clerk

1 INTRODUCED BY COUNCILMAN EAGAN  
2 JUNE 27, 2022

3  
4 BILL NO. 9799

ORDINANCE NO.

5  
6 **ORDINANCE AMENDING ORDINANCE NO. 8747 ESTABLISHING A**  
7 **GRADE AND STEP SCHEDULE FOR FULL TIME UNIFORMED**  
8 **EMPLOYEES AND DISPATCHERS BY REMOVING THE POSITION**  
9 **OF “STUDENT POLICE OFFICER”.**

10  
11 WHEREAS, the Police Chief recommends that the City utilize a Police Training  
12 Reimbursement Agreement as an incentive to attract and retain Academy Recruits for  
13 employment within the Police Department, and

14  
15 WHEREAS, Police Recruits cannot be employees under the Police Training  
16 Reimbursement Agreement.

17  
18 **NOW, THEREFORE, BE IT ORDAINED BY THE COUNCIL OF THE CITY OF**  
19 **FLORISSANT, ST. LOUIS COUNTY, MISSOURI, AS FOLLOWS:**

20  
21 Section 1: Ordinance no. 8747, establishing a grade and step schedule for full time  
22 uniformed employees and dispatchers is hereby amended by removing the title of “Student  
23 Police Officer”

24  
25 Section 2: This ordinance shall become in force and effect immediately upon its passage  
26 and approval.

27 Adopted this \_\_\_\_ day of \_\_\_\_\_, 2022.

28  
29  
30 \_\_\_\_\_  
31 Joseph Eagan, Council President

32  
33 Approved this \_\_\_\_ day of \_\_\_\_\_, 2022.

34  
35  
36 \_\_\_\_\_  
37 Timothy J. Lowery, Mayor

38  
39 ATTEST:  
40 \_\_\_\_\_  
41 Karen Goodwin, MPPA/MMC/MRCC  
42 City Clerk

1 INTRODUCED BY COUNCILMAN EAGAN  
2 JUNE 27<sup>TH</sup>, 2022

3  
4 BILL NO. 9800

ORDINANCE NO.

5  
6 **ORDINANCE AUTHORIZING A TRANSFER OF \$111,000 FROM**  
7 **ESCROW FUND ACCT 13-20301 "FORFEITURE ESCROW" TO**  
8 **GENERAL FUND ACCT 01-4-34511 "POLICE FORFEITURE**  
9 **REVENUE" AND AN APPROPRIATION OF \$111,000 TO GENERAL**  
10 **FUND ACCT 01-5-49-61000 "POLICE FORFEITURE EXPENDITURES"**  
11 **FOR VARIOUS POLICE EXPENDITURES.**

12  
13 BE IT ORDAINED BY THE COUNCIL OF THE CITY OF FLORISSANT, ST. LOUIS  
14 COUNTY, MISSOURI, AS FOLLOWS:

15  
16 Section 1: There is hereby transferred \$111,000 from Escrow Fund acct 13-20301  
17 "Forfeiture Escrow" to General Fund Acct 01-4-34511 "Police Forfeiture Revenue"; and

18 Section 2: There is hereby appropriated \$111,000 to General Fund Acct 01-5-49-61000  
19 "Police Forfeiture Expenditures" for office furniture, personnel equipment and vehicle  
20 equipment for the police department.

21 Section 3: This ordinance shall become in force and effect immediately upon passage  
22 and approval.

23  
24 Adopted this \_\_\_\_ day of \_\_\_\_\_, 2022.

25  
26  
27  
28 \_\_\_\_\_  
29 Joseph Eagan  
30 President of the Council  
31 City of Florissant

32  
33 Approved this \_\_\_\_ day of \_\_\_\_\_, 2022.

34  
35  
36  
37 \_\_\_\_\_  
38 Timothy J. Lowery  
39 Mayor, City of Florissant

40  
41 ATTEST:

42  
43  
44 \_\_\_\_\_  
45 Karen Goodwin, MPPA/MMC/MRCC  
46 City Clerk

# FLORISSANT CITY COUNCIL

## AGENDA REQUEST FORM

Date: \_\_\_\_\_

**Mayor's Approval:**

Agenda Date Requested: 6/23/2022

Description of request:

Transfer \$111,000 from Escrow Fund acct 13-20301 "Forfeiture Escrow" to General Fund Acct 01-4-34511 "Police Forfeiture Revenue" .

Appropriate \$111,000 to General Fund Acct 01-5-49-61000 "Police Forfeiture Expenditures" for various police expenditures per 6/23/22 memo.

Department:

Recommending Board or Commission:

Type of request:

Ordinances	X	Other	X
Appropriation	x	Liquor License	
Transfer		Hotel License	
Zoning Amendment		Special Presentations	
Amendment		Resolution	
Special Use Transfer		Proclamation	
Special Use		Subdivision	
Budget Amendment			
	Y/N		Y/N
Public Hearing needed: <b>Yes / No</b>		3 readings? : <b>Yes / No</b>	Y

Back up materials attached:	Back up materials needed:
Minutes	Minutes
Maps	Maps
Memo	Memo
Draft Ord.	Draft Ord.

**Note:** Please include all attachments necessary for documents to be generated for inclusion on the Agenda. All agenda requests are to be turned in to the City Clerk by 5pm on Tuesday prior to the Council meeting.

For City Clerk Use Only:

Introduced by: \_\_\_\_\_

PH Speaker: \_\_\_\_\_

# FLORISSANT POLICE DEPARTMENT

## MEMORANDUM

**Date:** 06-23-2022

**To:** Mayor Timothy Lowery

**From:** Chief Timothy Fagan

**Subject:** Money Transfer

*11 6-23-22*

We request the transfer of funds from account 13-20301 Forfeiture Escrow into account 01-5-49-61000 Police Forfeiture Expenditures for the following anticipated expenditures:

Office Furniture	\$ 4,000.00
Handgun Lights, Holsters and related equipment.	\$ 35,000.00
Spike Strips and related equipment for Police Vehicles	\$ 15,000.00
Radars and related equipment for Police Vehicles	\$ 17,500.00
Car Kennels and related equipment for Police K9 Vehicles	\$ 15,000.00
Ballistic vests for police officers	\$ 10,000.00
Trunk box organizers for police vehicles	\$ 11,000.00
Drone Command storage box for Police Vehicle	\$ 3,500.00
<hr/>	
Total	\$ 111,000.00

The total amount requested \$ 111,000.00

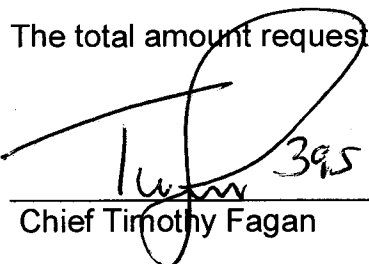
  
\_\_\_\_\_  
Chief Timothy Fagan



1 INTRODUCED BY COUNCILMAN EAGAN  
2 JUNE 27, 2022

3  
4 BILL NO. 9801

ORDINANCE NO.

5  
6 **ORDINANCE TO INCREASE PUBLIC SAFETY REVENUE ACCOUNT**  
7 **NO. 17-4-17310 “INSURANCE PROCEEDS” WITH FUNDS RECEIVED IN**  
8 **THE AMOUNT OF \$27,343 AND AN APPROPRIATION OF THE SAME**  
9 **AMOUNT TO ACCOUNT NO. 17-5-17-61000 “CAPITAL ADDITIONS-**  
10 **VEHICLES” FOR THE PURCHASE OF A 2022 DODGE DURANGO.**

11  
12 BE IT ORDAINED BY THE COUNCIL OF THE CITY OF FLORISSANT, ST. LOUIS  
13 COUNTY, MISSOURI, AS FOLLOWS:

14  
15 Section 1: Public Safety Fund Acct 17-4-17310 "Insurance Proceeds" is hereby increased  
16 by \$27,343 from insurance funds received related to 2020 Dodge Durango Police Vehicle #8;  
17 and

18  
19 Section 2: There is hereby appropriated, \$27,343.00 to Public Safety Fund Acct 17-5-  
20 17-61000 to purchase a 2022 Dodge Durango for approximately \$36,000., and

21  
22 Section 3: This ordinance shall become in force and effect immediately upon its  
23 passage and approval.

24  
25  
26 Adopted this \_\_\_\_\_ day of \_\_\_\_\_, 2022.

27  
28  
29 \_\_\_\_\_  
30 Joseph Eagan  
31 President of the Council  
32 City of Florissant  
33

34  
35 Approved this \_\_\_\_\_ day of \_\_\_\_\_, 2022.

36  
37  
38 \_\_\_\_\_  
39 Timothy J. Lowery  
40 Mayor, City of Florissant  
41

42  
43 ATTEST:

44  
45 \_\_\_\_\_  
46 Karen Goodwin, MPPA/MMC/MRCC  
47 City Clerk  
48

# FLORISSANT CITY COUNCIL

## AGENDA REQUEST FORM

Date: 6/23/22

Mayor's Approval:

Agenda Date Requested:

6/23/2022

**Description of request:**

Appropriate \$27,343 to Public Safety Fund Acct 17-4-17310 "Insurance Proceeds" related to 2020 Dodge Durango Police Vehicle #8.

Appropriate \$27,343.00 to Public Safety Fund Acct 17-5-17-61000 to purchase a 2022 Dodge Durango for approximately \$36,000.

The difference between the estimated cost and the insurance proceeds approx \$8,400 will be used from the Police Tahoe budget line of \$38,000 since this vehicle was not available to purchase due to manufacturers production issues

Department: Police Department

Recommending Board or Commission:

**Type of request:**

Ordinances	X	Other	X
Appropriation	x	Liquor License	
Transfer		Hotel License	
Zoning Amendment		Special Presentations	
Amendment		Resolution	
Special Use Transfer		Proclamation	
Special Use		Subdivision	
Budget Amendment			

Y/N

Y/N

Public Hearing needed: **Yes / No**

3 readings? : **Yes / No**

Y

**Back up materials attached:**

**Back up materials needed:**

Minutes		Minutes	
Maps		Maps	
Memo	x	Memo	
Draft Ord.		Draft Ord.	

**Note:** Please include all attachments

For City Clerk Use Only:

# FLORISSANT POLICE DEPARTMENT

## MEMORANDUM

Date: 06-15-2022

To: Chief Timothy Fagan

From: Major Randy Boden

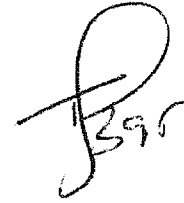

Subject Replacement Police Vehicle Purchase 2022 Dodge Durango

Sir;

As approved in the FY 2022 budget, the department is purchasing Six 2022 Dodge Durango AWD Police Vehicles. State bid CC220022002 was awarded to Landmark Dodge located in Independence, Mo. The state bid clearly outlines all of the equipment on the vehicle and the options that can be requested. I reviewed the state bid outlined from Landmark Dodge for the Six vehicles. The cost per vehicle including delivery fee is \$36,088.74.

I received a quote from Michael Benz, Fleet Sales Manager, Behlmann Chrysler Dodge Jeep Ram, 175 Turnbull Trail, Troy Missouri 63379 636-462-3600. This quote is for the exact same equipped vehicles as represented on the state bid. The quote from Behrman is \$35,682.00. The Department has purchased six vehicles from Bellman Chrysler Dodge Jeep Ram for the FY22 budget and they are an approved vendor for the City of Florissant.

On 01/25/2022 Police Vehicle #8, which is a 2020 Dodge Durango was totaled in a vehicular crash (report #22-000484). The City of Florissant is receiving an insurance payment for the vehicle #8 in the amount of \$27,343.00. The cost to purchase a new replacement vehicle is \$35,682.00. This would leave a difference of \$8,339.00.

*N/A* Further, an additional \$2,300.00 is need for equipment install for a total of ~~\$10,639.00~~ difference. This vehicle purchase would be an additional purchase to the six vehicles already received and would replace vehicle #8 which was not scheduled to be replaced.

To cover this difference the Police Department is not purchasing the Police Tahoe Vehicle in which \$38,000.00 was approved in FY22. The Police Tahoe package was closed immediately after it was opened and no orders can be placed for those vehicles.

It is requested to appropriate \$27,343.00 in funds <sup>to</sup> ~~from~~ account 17-4-17310 Insurances Proceeds. ~~To appropriate \$10,639.00 from Account 17-5-1761000 Capital Improvement Police Fund.~~ This would be a total of \$37,982.00 for new vehicle purchase and equipment install. *K-9*

Respectfully Submitted,

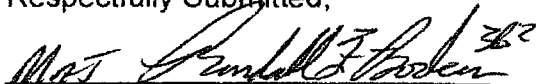
  
Major Randy Boden #362