



FLORISSANT CITY COUNCIL AGENDA
City Hall
955 rue St. Francois
Monday, December 13, 2021
7:00 PM
Karen Goodwin, MMC/MRCC



I. PLEDGE OF ALLEGIANCE

II. ROLL CALL OF MEMBERS

III. APPROVAL OF MINUTES

- City Council Meeting and Executive Meeting minutes of November 22, 2021

IV. HEARING FROM CITIZENS

V. COMMUNICATIONS

VI. PUBLIC HEARINGS

None		
------	--	--

VII. OLD BUSINESS

A. BILLS FOR SECOND READING

S9730	Ordinance authorizing a Special Use Permit to Kingston 10, LLC to allow for the operation of a restaurant/bar for the property located at 1157-1159 N. Hwy 67. (Postponed to this date from 11/22/2021)	Mulcahy
9744	Ordinance to authorize a Special Use Permit to Tamir LLC to allow for the operation of a sit-down, carry-out restaurant for the property located at 8457 N. Lindbergh.	Eagan

VIII. NEW BUSINESS

A. BOARD APPOINTMENTS

B. REQUESTS

Liquor (Ward 6) Application	Request to approve a Full Liquor by the Drink license for Kingston 10, LLC for a restaurant/bar located at 1157-1159 N. Hwy 67. (Postponed to this date on 11/22/2021)	Dean Treston
Liquor (Ward 9) Application	Request for a Full Liquor by the Drink license for Plush Lounge located at 12667 New Halls Ferry Road. (Postponed to this date on 11/22/2021)	Prince Koroma
Special Use Transfer (Ward 6)	Request to accept the application for a transfer of an existing non-conforming Special Use from Henke's Tavern to Flomo LLC d/b/a Henke's tavern for the operation of a restaurant-bar located at 901 N. Lafayette.	Mark Goldstein
Liquor (Ward 6) Application	Request for a Full Liquor by the Drink license for Henke's Tavern located at 901 N. Lafayette.	Mark Goldstein
Special Use Transfer (Ward3)	Request to transfer Special Use permit no. 7356 from the Beck Group LLC d/b/a Little Caesar's Pizza to Clotgott Enterprises, LLC d/b/a Little Caesar's Pizza for the operation of a restaurant located at 340 Howdershell Road.	Geoffray Clotfelter

C. *BILLS FOR FIRST READING*

E9745	Ordinance authorizing transfer of an existing non-conforming Special Use from Henke's Tavern to Flomo LLC d/b/a Henke's Tavern for the operation of a restaurant-bar located at 901 N. Lafayette.	Mulcahy
E9746 Memo	Ordinance amending ordinance number 8008 establishing the Property Acquisition Program by updating certain sections.	Schildroth
9747 Memo	Ordinance of the city of Florissant, Missouri, authorizing and directing the submission of a ballot proposition to the qualified voters of the city of Florissant, Missouri, to consider imposing a local use tax at the same rate as the local sales tax of the city of Florissant, Missouri, for purchases from out-of-state vendors that exceed two thousand dollars.	Council as a whole
9748 Memo	Ordinance calling an election in the city of Florissant, Missouri, on the question of issuing General Obligation Bonds for the purpose of constructing an aquatic center.	Council as a whole
E9749 Memo	Ordinance authorizing the mayor to enter into an agreement to accept ownership on behalf of the City of Florissant of real estate property located at 2 Menke Place, as gifted to the city.	Schildroth

E9750	Ordinance authorizing a transfer of Special Use permit no. 7356 from the Beck Group LLC d/b/a Little Caesar's Pizza to Clotgott Enterprises, LLC d/b/a Little Caesar's Pizza for the operation of a restaurant located at 340 Howdershell Road.	Eagan
E9751 Memo	Ordinance amending ordinance no. #8743 establishing a new compensation plan for seasonal employees of the City of Florissant to allow for a correction.	Schildroth

IX. COUNCIL ANNOUNCEMENTS

X. MESSAGE FROM THE MAYOR

XI. ADJOURNMENT

HAPPY HOLIDAYS FROM THE CITY OF FLORISSANT!

THIS AGENDA WAS POSTED ON THE BULLETIN BOARD IN THE LOBBY AT CITY HALL AND ON THE CITY WEBSITE AT FLORISSANTMO.COM ON DECEMBER 10TH, 2021 BY 12:00 PM.

ANY ONE WISHING TO ATTEND THE COUNCIL MEETING WHO HAS SPECIAL NEEDS SHOULD CONTACT THE CITY CLERK BY NOON ON MONDAY, DECEMBER 13, 2021.

CITY OF FLORISSANT



COUNCIL MINUTES

November 22, 2021

The Florissant City Council met in regular session at Florissant City Hall, 955 rue St. Francois on Monday, November 22, 2021 at 7:00 p.m. with Council President Schildroth presiding. The Chair asked everyone in attendance to stand and join in reciting the Pledge of Allegiance.

On Roll Call the following Councilmembers were present: Manganelli, Caputa, Schildroth, Mulcahy, Pagano, Parson, Siam, and Harris. Also present was Mayor Timothy Lowery, City Clerk Karen Goodwin, and City Attorney John Hessel. A quorum being present the Chair stated that the Council Meeting was in session for the transaction of business.

Councilman Manganelli moved to approve the City Council Minutes of November 8th, 2021, seconded by Siam. Motion carried.

The next item on the Agenda was *Proclamation*.

Legacy Jackson received a Proclamation presented by Mayor Lowery for her hard work and positive impact on the world. Legacy has created a 501(c)(3) called Little Legacies which supports many in need around the St Louis area. Mayor Lowery thanked Legacy for all her work and for representing the community of Florissant.

The next item on the Agenda was *Resolution*.

The Council as a whole introduced Resolution 1033 "A Resolution of the City Council and Mayor of the City of Florissant recognizing Diana Weidinger for her dedication and service to the City of Florissant". Councilman Mulcahy made a motion for a second reading, seconded by Schildroth. Motion carried, Resolution 1033 was read for a second time. Councilman Mulcahy made a motion for a third reading, seconded by Pagano.

On roll call the Council voted: Manganelli yes, Eagan yes, Caputa yes, Schildroth yes, Mulcahy yes, Pagano yes, Parson yes, Siam yes, and Harris yes. Motion carried, Resolution 1033 was read for a third time. Before the final vote all interested parties were given an opportunity to be heard.

On roll call the Council voted: Manganelli yes, Eagan yes, Caputa yes, Schildroth yes, Mulcahy yes, Pagano yes, Parson yes, Siam yes, and Harris yes. Motion carried, Resolution 1033 passes.

30 Diana Weidinger thanked Mayor Lowery and the Council for the honor. Ms. Weidinger
31 recognized Karen Goodwin for all her help throughout the years as well as thanked Laura Click for her
32 work on the Chili Cook-off.

33 The next item on the Agenda was *Hearing from Citizens* of which there were none.

34 The next item on the Agenda was *Communications* of which there were none.

35 The next item on the Agenda was *Public Hearings*.

36 The City Clerk reported that Public Hearing 21-11-031 for the request to authorize a Special Use
37 Permit to Tamir LLC to allow for the operation of a sit-down, carry-out restaurant for the property located
38 at 8457 N. Lindbergh. The Chair declared the Public Hearing to be open.

39 Alvah Levine, 2025 S. Brentwood Blvd, noted he is the architect for Tamir, LLC. He stated the
40 property is an existing building which was closed due to Covid. Mr. Levine noted the Planning and
41 Zoning Commission requested landscaping would be added around the sign pole and adding a sight-proof
42 screening on the HVAC system. Mr. Adam, owner, noted the business will be a fast food restaurant called
43 Broadway Grill with chicken, fish, and burgers on the menu while being open from 10am to about 11pm
44 or midnight during the week and 10am to 2am on the weekends. He stated no alcohol would be sold and
45 no indoor seating, only to-go orders. Mr. Levine noted the property was subdivided with a 50-foot buffer
46 between the building in question and the residences in the rear. Councilman Eagan asked for a trash can
47 to be placed in the front of the property to cut down on trash Lindbergh. Councilman Caputa clarified the
48 walk up window would be for picking up food only.

49 Being no further comments, Councilman Eagan made a motion to close the Public Hearing,
50 seconded by Pagano. Motion carried.

51 The Chair stated that the next item on the agenda was *Second Readings*.

52 Councilman Mulcahy moved Bill No. 9730 an Ordinance authorizing a Special Use Permit to
53 Kingston 10, LLC to allow for the operation of a restaurant/bar for the property located at 1157-1159 N.
54 Hwy 67 be read for a second time, seconded by Schildroth. Motion carried.

55 Councilman Schildroth made a motion to suspend the rules, seconded by Mulcahy. Motion
56 carried.

57 Dean Treston, petitioner, clarified the kitchen would be open until 9pm and the bar would be open
58 until 1am. Councilman Mulcahy noted concerns about proximity to the residents in the rear of the
59 building, potential activity at the back of the property, and the fencing in the rear. Mr. Treston stated a
60 fence would be put in the rear of the building so customers would not be able to get in the back, only

61 owners and deliveries. Mr. Mulcahy requested the fencing be addressed prior to the business moving
62 forward. Councilman Eagan noted his concerns with the residents at the rear of the property and the
63 fencing. Mr. Eagan asked that during operating hours the rear door remain closed and courteous of the
64 neighbors.

65 Councilman Mulcahy made a motion to postpone Bill No. 9730 until December 13, 2021,
66 seconded by Pagano. Motion carried.

67 Councilman Schildroth moved Bill No. 9731 an Ordinance adopting the budget for the City of
68 Florissant for the fiscal year commencing on December 1, 2021 and ending on November 30, 2022 and
69 providing for its effective date be read for a second time, seconded by Eagan. Motion carried and Bill
70 No. 9731 was read for a second time.

71 Councilman Schildroth moved that Bill no. 9731 be read for a third time, seconded by Caputa.
72 Motion carried and Bill No. 9731 was read for a third time and placed upon its passage. Before the final
73 vote all interested persons were given an opportunity to be heard.

74 On roll call the Council voted: Manganelli yes, Eagan yes, Caputa yes, Schildroth yes, Mulcahy
75 yes, Pagano yes, Parson yes, Siam yes, and Harris yes.

76 Whereupon the Chair declared Bill No. 9731 to have passed and become Ordinance No. 8739.

77 Councilman Schildroth moved that Bill No. 9732 an Ordinance repealing the Ordinance No. 8655
78 and authorizing the Mayor of the City of Florissant to enter into a contract with the law firm of Lewis
79 Rice, LLC, represented by John M. Hessel for legal services for the City of Florissant commencing on
80 December 1, 2021 and ending on November 30, 2022 be read for a second time, seconded by Pagano.
81 Motion carried and Bill No. 9732 was read for a second time.

82 Councilman Schildroth moved that Bill no. 9732 be read for a third time, seconded by Caputa.
83 Motion carried and Bill No. 9732 was read for a third time and placed upon its passage. Before the final
84 vote all interested persons were given an opportunity to be heard.

85 On roll call the Council voted: Manganelli yes, Eagan yes, Caputa yes, Schildroth yes, Mulcahy
86 yes, Pagano yes, Parson yes, Siam yes, and Harris yes.

87 Whereupon the Chair declared Bill No. 9732 to have passed and become Ordinance No. 8740.

88 Councilman Schildroth moved that Bill No. 9733 an Ordinance to amend Title II, Chapter 245
89 “Parks & Recreation” of the Florissant city code, Section 245. 130 “Fees for Use”, to adjust fees for use
90 of various park facilities be read for a second time, seconded by Caputa. Motion carried and Bill No.
91 9733 was read for a second time.

92 Councilman Schildroth moved that Bill No. 9733 be read for a third time, seconded by Pagano.
93 Motion carried and Bill No. 9733 was read for a third time and placed upon its passage. Before the final
94 vote all interested persons were given an opportunity to be heard.

95 On roll call the Council voted: Manganelli yes, Eagan yes, Caputa yes, Schildroth yes, Mulcahy
96 yes, Pagano yes, Parson yes, Siam yes, and Harris yes.

97 Whereupon the Chair declared Bill No. 9733 to have passed and become Ordinance No. 8741.

98 Councilman Harris moved that Bill No. 9734 an Ordinance to amend Chapter 245 “Parks and
99 Recreation” article XI “Old Fleurissant Golf Club” of the Florissant city code, subsection 245.610 “Fees
100 and Charges” to adjust fees for the golf course facility be read for a second time, seconded by Parson.
101 Motion carried and Bill No. 9734 was read for a second time.

102 Councilman Siam moved that Bill No. 9734 be read for a third time, seconded by Manganelli.
103 Motion carried and Bill No. 9734 was read for a third time and placed upon its passage. Before the final
104 vote all interested persons were given an opportunity to be heard.

105 On roll call the Council voted: Manganelli yes, Eagan yes, Caputa yes, Schildroth yes, Mulcahy
106 yes, Pagano yes, Parson yes, Siam yes, and Harris yes.

107 Whereupon the Chair declared Bill No. 9734 to have passed and become Ordinance No. 8742.

108 Councilwoman Pagano moved that Bill No. 9735 an Ordinance repealing ordinance no. 8587
109 establishing a new compensation plan for seasonal employees of the city of Florissant and containing an
110 effective date clause be read for a second time, seconded by Eagan. Motion carried and Bill No. 9735
111 was read for a second time.

112 Councilman Manganelli moved that Bill No. 9735 be read for a third time, seconded by Siam.
113 Motion carried and Bill No. 9735 was read for a third time and placed upon its passage. Before the final
114 vote all interested persons were given an opportunity to be heard.

115 On roll call the Council voted: Manganelli yes, Eagan yes, Caputa yes, Schildroth yes, Mulcahy
116 yes, Pagano yes, Parson yes, Siam yes, and Harris yes.

117 Whereupon the Chair declared Bill No. 9735 to have passed and become Ordinance No. 8743.

118 Councilman Schildroth moved that Bill No. 9736 an Ordinance repealing ordinance no. 8653
119 establishing a new compensation for part-time employees of the City of Florissant and containing an
120 effective date clause be read for a second time, seconded by Parson. Motion carried and Bill No. 9736
121 was read for a second time.

122 Councilman Mulcahy moved that Bill No. 9736 be read for a third time, seconded by Caputa.
123 Motion carried and Bill No. 9736 was read for a third time and placed upon its passage. Before the final
124 vote all interested persons were given an opportunity to be heard.

125 On roll call the Council voted: Manganelli abstain, Eagan yes, Caputa yes, Schildroth yes,
126 Mulcahy yes, Pagano yes, Parson yes, Siam yes, and Harris yes.

127 Whereupon the Chair declared Bill No. 9736 to have passed and become Ordinance No. 8744.

128 Councilman Siam moved that Bill No. 9737 an Ordinance amending Chapter 125 “Personnel”,
129 Article II “Classifications of Positions”, Section 125.065 “Wage Increases and Schedule” by deleting it
130 in its entirety and replacing it be read for a second time, seconded by Harris. Motion carried and Bill No.
131 9737 was read for a second time.

132 Councilman Eagan moved that Bill No. 9737 be read for a third time, seconded by Parson. Motion
133 carried and Bill No. 9737 was read for a third time and placed upon its passage. Before the final vote all
134 interested persons were given an opportunity to be heard.

135 On roll call the Council voted: Manganelli yes, Eagan yes, Caputa yes, Schildroth yes, Mulcahy
136 yes, Pagano yes, Parson yes, Siam yes, and Harris yes.

137 Whereupon the Chair declared Bill No. 9737 to have passed and become Ordinance No. 8745.

138 Councilman Schildroth moved that Bill No. 9738 an Ordinance repealing ordinance no. 8059
139 establishing a grade and step schedule for full time classified positions within the City of Florissant and
140 enacting in lieu thereof a new ordinance and containing an effective date clause be read for a second time,
141 seconded by Caputa. Motion carried and Bill No. 9738 was read for a second time.

142 Councilman Schildroth moved that Bill No. 9738 be read for a third time, seconded by Mulcahy.
143 Motion carried and Bill No. 9738 was read for a third time and placed upon its passage. Before the final
144 vote all interested persons were given an opportunity to be heard.

145 On roll call the Council voted: Manganelli yes, Eagan yes, Caputa yes, Schildroth yes, Mulcahy
146 yes, Pagano yes, Parson yes, Siam yes, and Harris yes.

147 Whereupon the Chair declared Bill No. 9738 to have passed and become Ordinance No. 8746.

148 Councilman Schildroth moved that Bill No. 9739 an Ordinance amending ordinance no. 8370
149 establishing a grade and step schedule for full time employees and dispatcher positions within the City
150 of Florissant and enacting in lieu thereof a new ordinance and containing an effective date clause be read
151 for a second time, seconded by Eagan. Motion carried and Bill No. 9739 was read for a second time.

152 Councilman Manganelli moved that Bill No. 9739 be read for a third time, seconded by Pagano.
153 Motion carried and Bill No. 9739 was read for a third time and placed upon its passage. Before the final
154 vote all interested persons were given an opportunity to be heard.

155 On roll call the Council voted: Manganelli yes, Eagan yes, Caputa yes, Schildroth yes, Mulcahy
156 yes, Pagano yes, Parson yes, Siam yes, and Harris yes.

157 Whereupon the Chair declared Bill No. 9739 to have passed and become Ordinance No. 8747.

158 Councilman Caputa moved to accept Substitute Bill No. 9740, seconded by Mulcahy. Motion
159 carried.

160 Councilman Caputa moved that Substitute Bill No. 9740 an Ordinance providing for the repeal
161 of chapters 500, 505, and 510 of the code of ordinances of the City of Florissant, Missouri as amended
162 relating to the building code and enacting in lieu thereof a new chapter 500, a new chapter 505, and a
163 new chapter 510 on the same subject with certain modifications be read for a second time, seconded by
164 Pagano. Motion carried and Substitute Bill No. 9740 was read for a second time.

165 Councilman Harris moved that Substitute Bill No. 9740 be read for a third time, seconded by
166 Caputa. Motion carried and Substitute Bill No. 9740 was read for a third time and placed upon its passage.
167 Before the final vote all interested persons were given an opportunity to be heard.

168 On roll call the Council voted: Manganelli yes, Eagan yes, Caputa yes, Schildroth yes, Mulcahy
169 yes, Pagano yes, Parson yes, Siam yes, and Harris yes.

170 Whereupon the Chair declared Substitute Bill No. 9740 to have passed and become Ordinance
171 No. 8748.

172 Councilman Manganelli moved that Bill No. 9742 an Ordinance amending chapter 125
173 “Personnel”, Article VI “Leave Policies”, Division 2 “Vacations” by deleting it in its entirety and
174 replacing it be read for a second time, seconded by Pagano. Motion carried and Bill No. 9742 was read
175 for a second time.

176 Councilman Mulcahy moved that Bill No. 9742 be read for a third time, seconded by Parson.
177 Motion carried and Bill No. 9742 was read for a third time and placed upon its passage. Before the final
178 vote all interested persons were given an opportunity to be heard.

179 On roll call the Council voted: Manganelli yes, Eagan yes, Caputa yes, Schildroth yes, Mulcahy
180 yes, Pagano yes, Parson yes, Siam yes, and Harris yes.

181 Whereupon the Chair declared Bill No. 9742 to have passed and become Ordinance No. 8749.

182 Councilman Parson moved that Bill No. 9743 an Ordinance appropriating the Community
183 Development Block Grant (CDBG) funds for the 2021 Fiscal Year for the City of Florissant be read for
184 a second time, seconded by Schildroth. Motion carried and Bill No. 9743 was read for a second time.

185 Councilman Harris moved that Bill No. 9743 be read for a third time, seconded by Siam. Motion
186 carried and Bill No. 9743 was read for a third time and placed upon its passage. Before the final vote all
187 interested persons were given an opportunity to be heard.

188 On roll call the Council voted: Manganelli yes, Eagan yes, Caputa yes, Schildroth yes, Mulcahy
189 yes, Pagano yes, Parson yes, Siam yes, and Harris yes.

190 Whereupon the Chair declared Bill No. 9743 to have passed and become Ordinance No. 8750.

191 The Chair stated the next item on the agenda was *Board Appointments*.

192 Councilman Mulcahy moved to appoint Gary Thieme, 875 Rue St. Jacques, to the Landmark and
193 Historic District Commission with a term expiring on 11/22/2024. Seconded by Eagan, motion carried
194 and the appointment was made.

195 Councilman Schildroth moved to accept the Mayor's appointment of Ronald Wagner, 703
196 Chateau Valley Dr, to the Economic Development Commission with a term expiring 11/22/2024.
197 Seconded by Pagano, motion carried and the appointment was made.

198 Councilman Caputa moved to accept the Mayor's appointment of Lashonda Sessions, 3834 Pointe
199 Forest Dr, to the Economic Development Commission as an alternate with a term expiring 11/22/2024.
200 Seconded by Pagano, motion carried and the appointment was made.

201 Councilman Caputa moved to accept the Mayor's appointment of Kevin Hampton, 11890
202 Featherwood Dr, to the Economic Development Commission as an alternate with a term expiring
203 11/22/2024. Seconded by Pagano, motion carried and the appointment was made.

204 The Chair stated the next item on the agenda was *Requests*.

205 Councilman Mulcahy moved to postpone the Request to approve a Full Liquor by the Drink
206 license for Kingston 10, LLC for a restaurant/bar located at 1157-1159 N. Hwy 67 to the December 13,
207 2021 meeting, seconded by Caputa. Motion carried.

208 Councilman Schildroth moved to suspend the rules for the purpose of discussion for the Request
209 for a Full Liquor by the Drink license for Plush Lounge located at 12667 New Halls Ferry Road, seconded
210 by Eagan.

211 Councilman Eagan stated he reviewed the information from the meeting which took place on
212 December 14, 2020 which was the initial approval for the liquor license and had follow up questions

213 based on information and media which has been shared regarding Plush Lounge. Mr. Eagan noted at the
214 meeting in December 2020 it was verified the main focus of the business would be as a restaurant and
215 potentially turn into a hookah lounge if the right ventilation is installed. He continued one main focus of
216 the property would be maintaining the property and picking up the trash in the parking lot. Prince
217 Koroma, petitioner, stated the building did have a kitchen in the building. Chief Fagan noted the business
218 does have kitchen equipment inside but it has not been approved and is not operational. Mr. Koroma
219 stated he misunderstood the process of picking up the liquor license and his main focus was on the Special
220 Use Permit while making sure the building was brought back up to code. He stated the video was a
221 promotional video to be completed for the soft opening and some of the video was not approved content
222 by him. Mr. Koroma stated the building was in worse condition than he realized when signing the lease
223 and his main focus has been getting the occupancy permit, but he wanted to do a soft opening over the
224 weekend to make a little money without the kitchen being completed. John Hessel stated the business
225 would have to go back to Planning and Zoning if the owner would like to open the business as a bar
226 instead of a restaurant/bar and receive a new Special Use Permit. Councilman Eagan stated he does not
227 feel comfortable approving a liquor license for a business which is considering operating differently than
228 what the council was told. Mr. Hessel noted the hookah would have to be presented to the City Council
229 to allow for the smoking to be included within the Special Use Permit. Councilman Parson noted his
230 concerns matched those with Councilman Eagan. Mr. Koroma stated the earliest his kitchen could be
231 done would be approximately a week and it would be better to postpone the vote until the following
232 meeting. He noted he relieved the marketing manager of their duties because they were not advertising
233 the business as he would like and has since taken control of the Facebook page in question. Mr. Koroma
234 stated the reason the page is called Plush Hookah Lounge is because the name of his LLC is Plush Hookah
235 Lounge LLC but has no intention of allowing hookah inside his building without the proper permitting
236 which was previously discussed. He continued the soft opening would be for friends and family by invite
237 only and the codes would be sent out by him to any who sent a message to the business Facebook page.
238 Councilman Eagan mentioned the dance hall permit and the business needing the permit if he were to
239 want to charge a cover charge for events or any evenings. Mayor Lowery clarified the business was going
240 to have two events over the weekend without holding a liquor license with the City of Florissant. Mr.
241 Koroma stated he misunderstood the liquor license needed to be paid for and picked up right after the
242 approval. He stated he believed once he had a passing occupancy inspection, he could pick up the business
243 license, occupancy permit, and liquor license all at the same time rather than needing to reapply when

244 renewal time comes. Mayor Lowery stated it was unclear whether or not the petitioner had full knowledge
245 and control of the Facebook page based on the information shared.

246 Councilman Parson made a motion to postpone the request to the December 13, 2021 meeting,
247 seconded by Pagano. Motion carried.

248 The Chair stated that the next item on the agenda was *Bills for First Reading*.

249 Councilman Mulcahy introduced Bill No. 9744 an Ordinance to authorize a Special Use Permit
250 to Tamir LLC to allow for the operation of a sit-down, carry-out restaurant for the property located at
251 8457 N. Lindbergh was read for the first time.

252 The next item on the Agenda was *Council Announcements*.

253 Councilman Parson announced there would be a joint Wards 8 and 9 meeting at the James J.
254 Eagan Center on December 8 at 7pm.

255 Councilman Manganello wished everyone a Happy Thanksgiving and the street sweeper was out
256 cleaning Ward 2.

257 Councilman Eagan encouraged residents to donate to the TEAM Food Pantry especially during
258 the holiday season. He noted Wednesday, November 24, 2021 would be the annual Guns and Hoses
259 Boxing Match which will include a match with Florissant Police Department's Dustin Chandler.

260 Councilman Caputa wished everyone a Happy Thanksgiving and thanked all service members
261 who are deployed and unable to be home for the holiday. He reminded residents to not keep firearms in
262 their vehicle and to not leave vehicles running unattended in the mornings.

263 Councilwoman Pagano wished everyone a Happy Thanksgiving. She thanked the residents who
264 attended the joint Ward 5 and 7 meeting. Ms. Pagano wished her granddaughter a Happy Fifth Birthday.

265 Councilman Mulcahy wished everyone a Happy Thanksgiving and congratulated Diana
266 Weidinger for her receiving her resolution and thanked her for all her hard work for the Fall Festival.

267 Councilman Schildroth wished everyone a Happy Thanksgiving and thanked the resident of Ward
268 5 and 7 for their participation in the joint Ward meeting. He congratulated Diana Weidinger on her
269 Resolution and thanked her for her contributions to the city.

270 The next item was *Mayor Announcements*.

271 Mayor Lowery wished everyone a Happy Thanksgiving. He noted the Miracle on St. Francois
272 Street event will be taking place on November 27th from 2pm to 9pm and will include photos with Santa,
273 pony rides, Jingle Run for Kids, crafts, tree lighting ceremony, and golf cart parade as well as a 5pm
274 plaque dedication for Richard Henefer. Mayor Lowery stated on Sunday, November 28 from 1pm to 6pm

275 will be the Annual Old Town Christmas House Tour. He stated the Shrine has tablesapes and a raffle
276 going on with more information on their Facebook page.

277 Councilman Schildroth made a motion to cancel the December 27th, 2021 meeting due to the
278 Christmas holiday, seconded by Manganelli. Motion carried.

279 The Council President stated that the next regular City Council Meeting will be Monday,
280 December 13, 2021 at 7:00 pm.

281 Councilman Siam moved to adjourn the meeting, seconded by Pagano. Motion carried. The
282 meeting was adjourned at 8:20 p.m.

283

284

285

286

287

288



Karen Goodwin, MPPA/MMC/MRCC
City Clerk

The following Bills were signed by the Mayor:

- | | | |
|-----|-----------------|-----------|
| 289 | Bill No. 9731 | Ord. 8739 |
| 290 | Bill No. 9732 | Ord. 8740 |
| 291 | Bill No. 9733 | Ord. 8741 |
| 292 | Bill No. 9734 | Ord. 8742 |
| 293 | Bill No. 9735 | Ord. 8743 |
| 294 | Bill No. 9736 | Ord. 8744 |
| 295 | Bill No. 9737 | Ord. 8745 |
| 296 | Bill No. 9738 | Ord. 8746 |
| 297 | Bill No. 9739 | Ord. 8747 |
| 298 | Bill No. 9740 | Ord. 8748 |
| 299 | Bill No. 9742 | Ord. 8749 |
| 300 | Bill No. 9743 | Ord. 8750 |
| 301 | Resolution 1033 | |



CITY OF FLORISSANT
CITY COUNCIL
OPEN EXECUTIVE SESSION

November 22, 2021

The City Council of the City of Florissant met in open Executive Session on Monday, November 22nd, 2021 at 6:15 pm. in the Council Conference room with President Schildroth presiding. On Roll Call the following Council members were present: Schildroth, Mulcahy, Pagano, Parson, Siam, Harris, Manganelli, Eagan, Caputa. Also present was Mayor Timothy Lowery, City Clerk Karen Goodwin. City Attorney John Hessel and Police Chief Tim Fagan.

Councilman Eagan moved to go into closed session to confer with the City Attorney in accordance with Chapter 610.021 (1) of the Missouri Revised Statutes, seconded by Schildroth, on roll call the Council voted: Harris-yes, Manganelli-yes, Eagan-yes, Caputa-yes, Schildroth-yes, Mulcahy-yes, Pagano-yes, Parson-yes, Siam-yes. The Council proceeded into closed session.

Council conferred with the City Attorney regarding potential legal issues.

Council President Schildroth moved to return to open session at 6:50 pm, seconded by Caputa, on roll call the council voted: Harris-yes, Manganelli-yes, Eagan-yes, Caputa-yes, Schildroth-yes, Mulcahy-yes, Pagano-yes, Parson-yes, Siam-yes.

Council President Schildroth stated that the next item on the agenda was a presentation by Adam Davis from Bird Scooters. Mr. Davis provided an overview of the proposal for bringing Bird Scooters into Florissant. He stated that parameters could be set for location and time of use. Time being shorter than anticipated, he offered to return to answer any questions the Council might have.

There being no further business to discuss, Councilman Schildroth motioned to adjourn, seconded by Siam. Motion carried and the meeting adjourned at 7:00 p.m.

Karen Goodwin
City Clerk

1 INTRODUCED BY COUNCILMAN MULCAHY
2 DECEMBER 13, 2021

3
4 SUBSTITUTE BILL NO. 9730

ORDINANCE NO.

5
6 **ORDINANCE AUTHORIZING A SPECIAL USE PERMIT TO KINGSTON**
7 **10, LLC TO ALLOW FOR THE OPERATION OF A RESTAURANT/BAR**
8 **FOR THE PROPERTY LOCATED AT 1157-1159 N. HWY 67.**
9

10 WHEREAS, the Florissant Zoning Ordinance authorizes the City Council of the City of
11 Florissant, by Special Permit, after public hearing thereon, to permit the location and operation
12 of a restaurant in the City of Florissant; and

13 WHEREAS, an application has been filed by Kingston 10, LLC d/b/a Kingston 10 to
14 allow for the operation of restaurant located at 1157-1159 N. Hwy 67, and

15 WHEREAS, the Planning and Zoning Commission at their meeting on October 18, 2021,
16 recommended that a Special Permit be granted; and

17 WHEREAS, due notice of public hearing no. 21-11-030 on said application to be held on
18 the 8th of November, 2021 at 7:00 P.M. by the Council of the City of Florissant was duly
19 published, held and concluded; and

20 WHEREAS, the Council, following said public hearing, and after due and careful
21 consideration, has concluded that the issuance of a Special Permit for a restaurant would be in
22 the best interest of the City of Florissant.

23
24 NOW, THEREFORE, BE IT ORDAINED BY THE COUNCIL OF THE CITY OF
25 FLORISSANT, ST. LOUIS COUNTY, MISSOURI, AS FOLLOWS:
26

27 Section 1: A Special Use Permit is hereby granted to Kingston 10, LLC d/b/a Kingston
28 10 to allow for the operation of restaurant located 1157-1159 N. Hwy 67 with the following
29 stipulation:
30

- 31 1. Maximum Occupant load shall be 62 as shown on plans.
- 32 2. Replace existing fence along the North property line with a 6-foot heavy duty
33 vinyl fence.
- 34 3. Rear door to the premises shall be kept closed to prevent noises to be directed
35 to residentially zoned properties.
- 36 4. All activities shall be conducted inside the premises.
- 37 5. No customer parking in the rear of the building.
38
39

40 Section 2: This ordinance shall become in force and effect immediately upon its passage
41 and approval.

42 Adopted this _____ day of _____, 2021.
43
44

45 _____
46 Keith Schildroth
President of the Council

47
48
49
50
51
52
53
54

Approved this _____ day of _____, 2021.

Timothy J. Lowery
Mayor, City of Florissant

ATTEST: _____
Karen Goodwin, MPPA/MMC/MRCC
City Clerk

1 INTRODUCED BY COUNCILMAN MULCAHY
2 NOVEMBER 8, 2021

3
4 BILL NO. 9730

ORDINANCE NO.

5
6 **ORDINANCE AUTHORIZING A SPECIAL USE PERMIT TO KINGSTON**
7 **10, LLC TO ALLOW FOR THE OPERATION OF A RESTAURANT/BAR**
8 **FOR THE PROPERTY LOCATED AT 1157-1159 N. HWY 67.**
9

10 WHEREAS, the Florissant Zoning Ordinance authorizes the City Council of the City of
11 Florissant, by Special Permit, after public hearing thereon, to permit the location and operation
12 of a restaurant in the City of Florissant; and

13 WHEREAS, an application has been filed by Kingston 10, LLC d/b/a Kingston 10 to
14 allow for the operation of restaurant located at 1157-1159 N. Hwy 67, and

15 WHEREAS, the Planning and Zoning Commission at their meeting on October 18, 2021,
16 recommended that a Special Permit be granted; and

17 WHEREAS, due notice of public hearing no. 21-11-030 on said application to be held on
18 the 8th of November, 2021 at 7:00 P.M. by the Council of the City of Florissant was duly
19 published, held and concluded; and

20 WHEREAS, the Council, following said public hearing, and after due and careful
21 consideration, has concluded that the issuance of a Special Permit for a restaurant would be in
22 the best interest of the City of Florissant.

23
24 NOW, THEREFORE, BE IT ORDAINED BY THE COUNCIL OF THE CITY OF
25 FLORISSANT, ST. LOUIS COUNTY, MISSOURI, AS FOLLOWS:
26

27 Section 1: A Special Use Permit is hereby granted to 10, LLC d/b/a Kingston 10 to
28 allow for the operation of restaurant located 1157-1159 N. Hwy 67 with the following
29 stipulation:
30

- 31 1. Maximum Occupant load shall be 62 as shown on plans.
32

33 Section 2: This ordinance shall become in force and effect immediately upon its passage
34 and approval.

35 Adopted this ____ day of _____, 2021.
36

37 _____
38 Keith Schildroth
39 President of the Council
40

41 Approved this ____ day of _____, 2021.
42

43 _____
44 Timothy J. Lowery
45 Mayor, City of Florissant

46 ATTEST: _____
47 Karen Goodwin, MPPA/MMC/MRCC
City Clerk

SPECIAL USE PERMIT APPLICATION
TO THE CITY OF FLORISSANT
PLANNING AND ZONING COMMISSION

Receipt
1/22/13



City Of Florissant – Public Works
314-839-7648

"Preserve and improve the health, safety, and welfare of our residents, businesses and the general public in the City of Florissant; while at the same time maintaining property values and improving the quality of life in the City of Florissant."

PLANNING & ZONING ACTION
RECOMMENDED APPROVAL
PLANNING & ZONING
CHAIRMAN

Council Ward 6 Zoning B3

Initial Date Petitioner Filed _____
Building Commissioner to complete
ward, zone & date filed

SIGN. [Signature] DATE: 10-18-21

SPECIAL PERMIT FOR Restaurant/Bar
Statement of what permit is being sought. (i.e., special permit for operation of a restaurant).

AMEND SPECIAL PERMIT #- _____ TO ALLOW FOR _____
ordinance # Statement of what the amendment is for.

LOCATION 1157-59 Highway 67
Address of property.

1) Comes Now Dean Treston Kingston 10 LLC
Enter name of petitioner. If a corporation, state as such. If applicable include DBA (Doing Business As)

and states to the Planning and Zoning Commission that he (she) (they) has (have) the following legal interest in the tract of land located in the City of Florissant, State of Missouri, as described on page 3 of this petition.

Legal interest in the Property) _____
State legal interest in the property. (i.e., owner of property, lease).
Submit copy of deed or lease or letter of authorization from owner to seek a special use.

2) The petitioner(s) further state(s) that the property herein described is presently being used for vacant and that the deed restrictions for the property do not prohibit the use which would be authorized by said Permit.

3) The petitioner(s) further states (s) that they (he) (she) are submitting a detailed site plan of the proposed or existing development showing location and use of all structures, off-street parking, and all other information required by the Zoning Ordinance or determined necessary by the Building Commissioner.

- 4) The petitioner(s) further state(s) that (he) (she) (they) shall comply with all of the requirements of the City of Florissant, including setback lines and off- street parking.
- 5) The petitioner (s) further (represent (s) and warrants (s) that they (he) (she) has (have) not made any arrangement to pay any commission gratuity or consideration, directly or indirectly to any official, employee or appointee of the City of Florissant, with respect to this application.
- 6) The petitioner(s) further state (s) that the Special Use Permit is sought for the following purposes, and no other, as listed in detail, all activities sought to be covered by the permit (i.e.; operation of a business, approval of building and/or site plans (preliminary and / or final), plan approval for signage, etc.):
- 7) The petitioner (s) state (s) the following factors and reason to justify the permit:
(If more space is needed, separate sheets maybe attached)

Dean Treston  / detrest@Adl.com 314 458 6005
 PRINT NAME SIGNATURE email and phone

FOR Kingston 10 LLC
 (company, corporation, partnership)

Print and sign application. If applicant is a corporation or partnership signature must be a CORPORATE OFFICER or a PARTNER. NOTE: Corporate officer is an individual named in corporate papers.

- 8) I (we) hereby certify that, as applicant (circle one of the following):
1. I (we) have a legal interest in the herein above described property.
 2. I am (we are) the duly appointed agent(s) of the petitioner (s), and that all information given here is true and a statement of fact.

Permission granted by the Petitioner assigning an agent (i.e. Architect) to present this petition in their behalf, to the Commission and/or Council. The petitioner must sign below, and provide contact information:

PRESENTOR SIGNATURE _____

ADDRESS _____
 STREET CITY STATE ZIP CODE

TELEPHONE / EMAIL _____ / _____
 BUSINESS

I (we) the petitioner (s) do hereby appoint _____ as
 Print name of agent.
 my (our) duly authorized agent to represent me (us) in regard to this petition.

 Signature of Petitioner authorizing an agent

NOTE: When the petitioner and/or his duly authorized agent appears before the Planning and Zoning Commission and to make a presentation, the same individuals must also appear before the City Council at the Public Hearing to make the presentation and no one else will be permitted to make the presentation to the City Council without authorized approval.

IF DESCRIPTIONS, PLATS OR SURVEYS ARE INACCURATE, OR IF THE PETITION APPLICATION IS NOT CORRECT OR COMPLETE, IT WILL BE RETURNED FOR ADDITIONS OR CORRECTIONS.

REQUIRED INFORMATION

Please mark an "X" in the appropriate type of operation, then fill in applicable section (a), (b) or (c).
Corporations are to submit copy of Missouri corporate papers with registration papers.

1) Type of Operation:

Individual _____ Partnership _____ Corporation _____

(a) If an individual:

(1) Name and Address _____

(2) Telephone Number _____

(3) Business Address _____

(4) Date started in business _____

(5) Name in which business is operated if different from (1) _____

(6) If operating under a fictitious name, provide the name and date registered with the State of Missouri, and a copy of the registration.

(b) If a partnership:

(1) Names & addresses of all partners _____

(2) Telephone numbers _____

(3) Business address _____

(4) Name under which business is operated _____

(5) If operating under fictitious name, provide date the name was registered with the State of Missouri, and a copy of the registration.

(c) If a corporation:

(1) Names & addresses of all partners Dean Treston 12521 EVENING Shade Dr Black Jack

(2) Telephone numbers 314 458 6005

(3) Business address 1157-59 Highway 67 Florissant Mo 63031

(4) State of Incorporation & a photocopy of incorporation papers Missouri

(5) Date of Incorporation 28th day of July 2021

(6) Missouri Corporate Number LC 1804737

(7) If operating under fictitious name, provide the name and date registered with the State of Missouri, and a copy of registration. N/A

(8) Name in which business is operated Kingston 10

(9) Copy of latest Missouri Anti-Trust. (annual registration of corporate officers) If the property location is in a strip center, give dimensions of your space under square footage and do not give landscaping Information.

Please fill in applicable information requested. If the property is located in a shopping center, provide the dimensions of the tenant space under square footage and landscaping information may not be required.

Name Dean Treston
Address 12501 Evening Shade Dr Black Jack, Mo, 63033
Property Owner Terry Henzi
Location of property 1157-59 Highway 67 Florissant Mo, 63031
Dimensions of property N/A
Property is presently zoned B3 Requests Rezoning To N/A
Proposed Use of Property Restaurant / Bar
Type of Sign LED Lit Box Sign Height 3' x 8'
Type of Construction Remodel III-B Number Of Stories 1
Square Footage of Building 2360 sq. ft Number of Curb Cuts N/A
Number of Parking Spaces 22 Sidewalk Length _____
Landscaping: No. of Trees N/A Diameter N/A
No. of Shrubs N/A Size N/A
Fence: Type N/A Length N/A Height N/A

PLEASE SUBMIT THE FOLLOWING INFORMATION ON PLANS OR DRAWINGS:

1. Zoning of adjoining properties.
2. Show location of property in relation to major streets and all adjoining properties.
3. Show measurement of tract and overall area of tract.
4. Proposed parking layout and count, parking lighting.
5. Landscaping and trash screening.
5. Location, sizes and elevations of signage.

PROVIDE LEGAL DESCRIPTION OF PROPERTY PERTAINING TO THIS PETITION

(Close legal description with acreage to the nearest tenth of an acre).

Provide a legal description of the property. If part of a shopping center, list address and show part of what shopping center (i.e.: 351 N. Highway 67 part of Florissant Meadows Shopping Center). If property is a single lot, list full written legal description with metes and bounds bearings and dimensions.

PROVIDE LOCATION MAP SHOWING AREA INVOLVING THIS PETITION

Provide a drawing of a location map showing the nearest major intersection.

OFFICE USE ONLY

Date Application reviewed _____

STAFF REMARKS: _____

Building Commissioner or Staff Signature

1
2
3

MEMORANDUM



4
5
6
7
8

CITY OF FLORISSANT- Building Division

" Preserve and improve the health, safety, and welfare of our residents, businesses and the general public in the City of Florissant; while at the same time maintaining property values and improving the quality of life in the City of Florissant."

9
10
11
12
13
14
15
16

To: Planning and Zoning Commissioners Date: October 13, 2021
From: Philip E. Lum, AIA-Building Commissioner c: Todd Hughes, P.E.,
Director Public Works
Deputy City Clerk
Applicant
File

17
18
19
20

Subject: 1159 N. Highway 67 (Kingston 10, LLC) Request Recommended Approval of a Special Use to allow for a Bar/Restaurant establishment in a 'B-3' Extensive Business District.

21
22

STAFF REPORT
CASE NUMBER PZ-101821-2

23
24

I. PROJECT DESCRIPTION:

This is a request for **recommended approval** of a Special Use, to allow for a bar/restaurant establishment at **1159 N. Highway 67**, in an existing 'B-3' Planned Commercial District.

25
26
27
28

II. EXISTING SITE CONDITIONS:

The existing property at **1159 N. Highway 67** is a tenant space on a 1.69 acre site with a shopping center and 2 other rear buildings in a 'B-3' Extensive Business District.

29
30
31
32
33
34
35
36

The subject property is approximately 59'-9"x 39'-7"= 2365 s.f. in the shopping center which is about 11,528 s.f.. There is a partial site plan attached which shows the boundary limits and existing front parking. The existing building was built in 1975 per County record.

37

III. SURROUNDING PROPERTIES:

38
39

The property to the West is Rallo Plaza at 1101 N. Highway 67, zoned similarly in the 'B-3' Extensive Business District. The properties to the North are houses along St Celeste in

40 the 'R-4' Single Family Dwelling District. The properties to the East are a car lot at 1285
41 N. Highway 67 and a church at 1325 N. Highway 67 in the 'B-3' Extensive Business District.

42
43 **IV. STAFF ANALYSIS:**

44 Plans received from the applicant include architect's plan of existing site with no
45 proposed changes and a preliminary floor plan.

46
47 Comments on Drawings A0.0 and A1.0 dated August 12, 2021 by Deru and Associates:

48
49 Site Plan: A site plan was requested indicating compliance with the parking code. It
50 appears on older aerials that about 51 parking spaces are striped, but some in the rear do
51 not have adequate drive lane access or are partial. Some spaces in front may need to be
52 adjust to fit within the property lines.

53
54 Parking required for the center as calculated by staff, using the info. provided:

55
56 Staff Calculations for bar restaurant:

57 *"1 space for every 3 seats plus 2 spaces for every 3 employees on the maximum sh(ft, or*
58 *12.0 per 1,000 GFA"*

59 Seats shown on plan $59/3=19$ staff assumed $4-6/2=4$, total required 23, site plan
60 indicates 22. No other tenants at this time, so complies.

61
62 **III. STAFF RECOMENDATIONS:**

63
64 **Suggested Motion:**

65 I move for Recommended Approval of a Special Use to allow for bar/restaurant
66 establishment in a 'B-3' Extensive Business District as shown on plans attached, subject
67 to the conditions set forth below with these conditions being part of the record:

- 68
69 **1.** Maximum Occupant load shall be 62 as shown on plans.

70
71
72 (End of report and suggested motion)

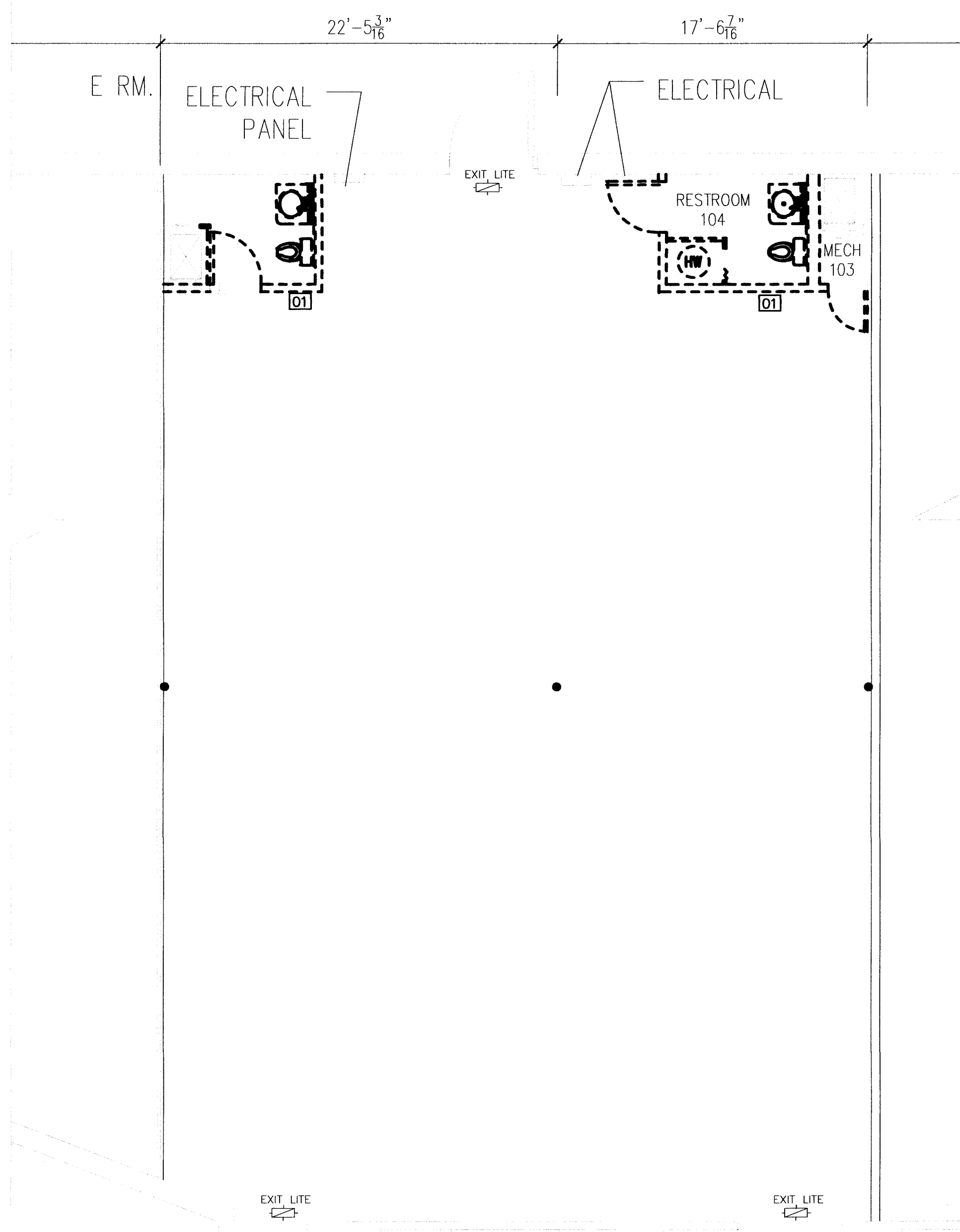

EXISTING FLOOR PLAN
3/16"=1'
NORTH

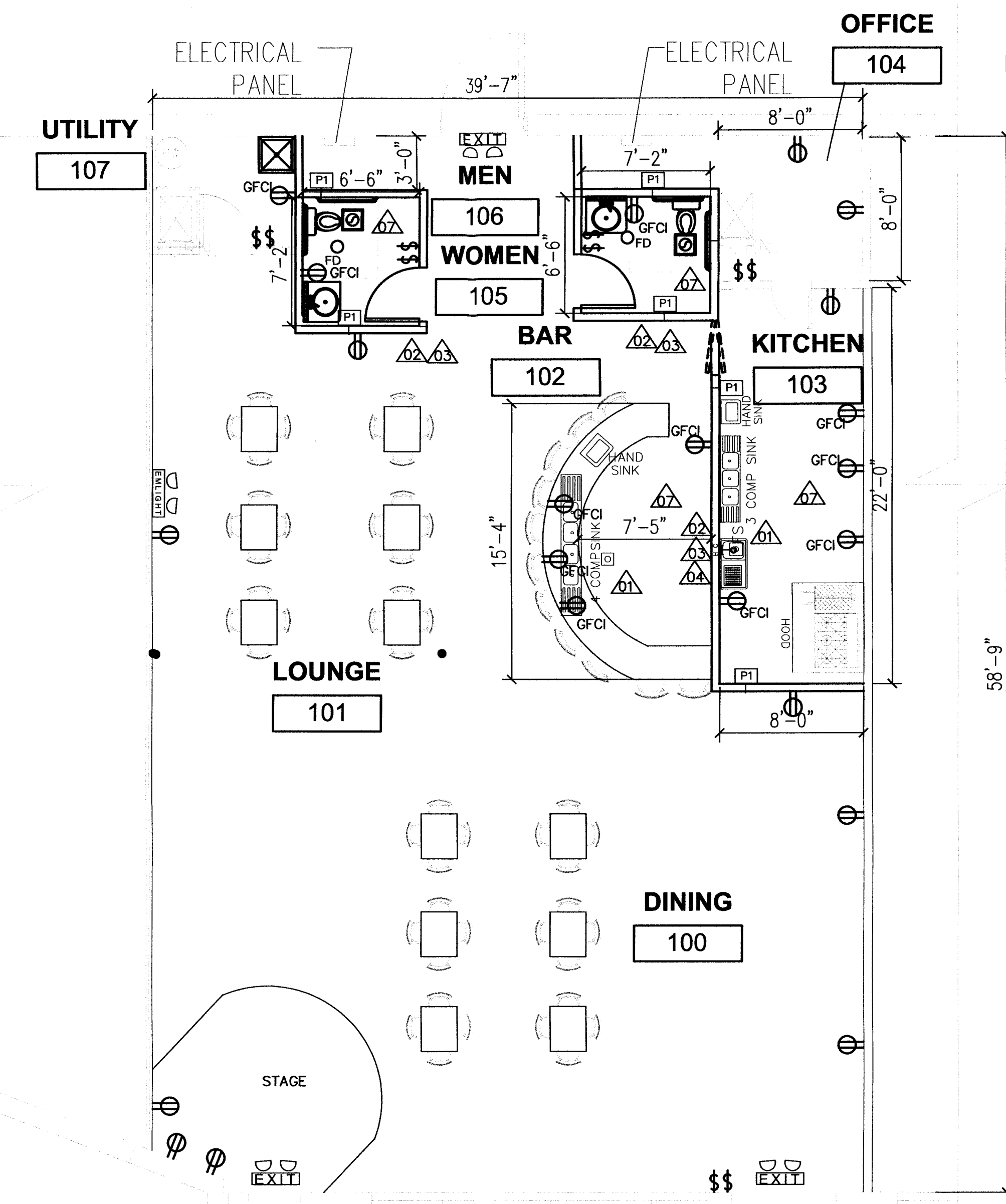

NEW FLOOR PLAN
3/16"=1'
NORTH

- DEMOLITION GENERAL NOTES**
- EXISTING ELECTRICAL PANEL TO REMAIN
 - REMOVE EXISTING WALLS AS INDICATED.
- DEMOLITION KEYED NOTES**
- REMOVE DRYWALL AND WALL FINISHES AS REQUIRED
 - REMOVE EXISTING DOOR.
 - REMOVE EXISTING PLUMBING FIXTURES AS INDICATED.

General Requirements:

These specifications and the accompanying drawings constitutes the furnishing of all labor, materials and equipment required to complete the installation of the systems as shown including all accessories, fittings, auxiliaries, and components required for the proper performance of the systems.

Work installed shall be in strict compliance with applicable 2018 IBC other state and local codes.

Contractors shall visit the site prior to bidding. Bids shall serve as evidence of knowledge of existing conditions. Field verify that all existing equipment is working conditions.

Furnish all labor, materials, equipment, and tools to perform carpentry work shown, noted or scheduled for a complete and finished installation.

All materials and equipment shall be commercial grade and shall carry a U.L. label.

Materials, products and equipment, including components thereof shall be new and such as appears on the Underwriter's Laboratory list of approved items and shall meet the requirements of recognized standards.

Secure and pay for all required permits and inspection certificates.

- FLOOR PLAN KEYED NOTES**
- PATCH FLOOR AFTER UNDERGROUND PLUMBING HAS BEEN INSPECTED
 - FRAME UP WALLS FOR NEW WALLS WITH 20GA, 3-5/8" METAL STUDS.
 - INSTALL 5/8" DRYWALL ON NEWLY FRAMED WALLS AND EXISTING OPEN WALLS AFTER COVER UP INSPECTION HAS BEEN APPROVED.
 - TAPE ALL NEW DRYWALL SEAMS AFTER SCREW INSPECTION.
 - PAINT ALL WALLS AFTER THE TAPING INSPECTION.
 - INSTALL NEW FLOORING AND COVE BASE AFTER THE PAINTING HAS BEEN COMPLETED.
 - INSTALL NEW DRYWALL CEILING FOR THE UTILITY ROOM, RESTROOMS, OFFICE, KITCHEN AND OVER BAR.
 - INSTALL NEW BAR AND STAGE AREA.
 - INSTALL NEW 36" INTERIOR DOORS.
 - INSTALL 5/8" MOISTURE RESISTANT DRYWALL FOR ALL PLUMBING WALLS
 - SEE A2.0 FOR DRYWALL CEILING DETAILS AND FINISH SCHEDULE.

DRAWING SYMBOL LEGEND:

- ⊖ RECEPTACLE 120V
- ⊕ RECEPTACLE 120V GROUND FAULT PROTECTED
- ⊙ SINGLE POLE SWITCH
- ⊚ 3-WAY SWITCH
- EXIT SIGN WITH EMERGENCY LIGHTING AND BATTERY BACK UP
- EMERGENCY LIGHTING AND BATTERY BACK UP
- EXIT SIGN WITH BATTERY BACK UP
- NEW TOILET EXHAUST FAN

FRAMED WALL HEIGHT BRACED AT THE TOP AT BOTTOM OF THE ROOF JOIST. (ALL WALLS TERMINATE AT THE CEILING)

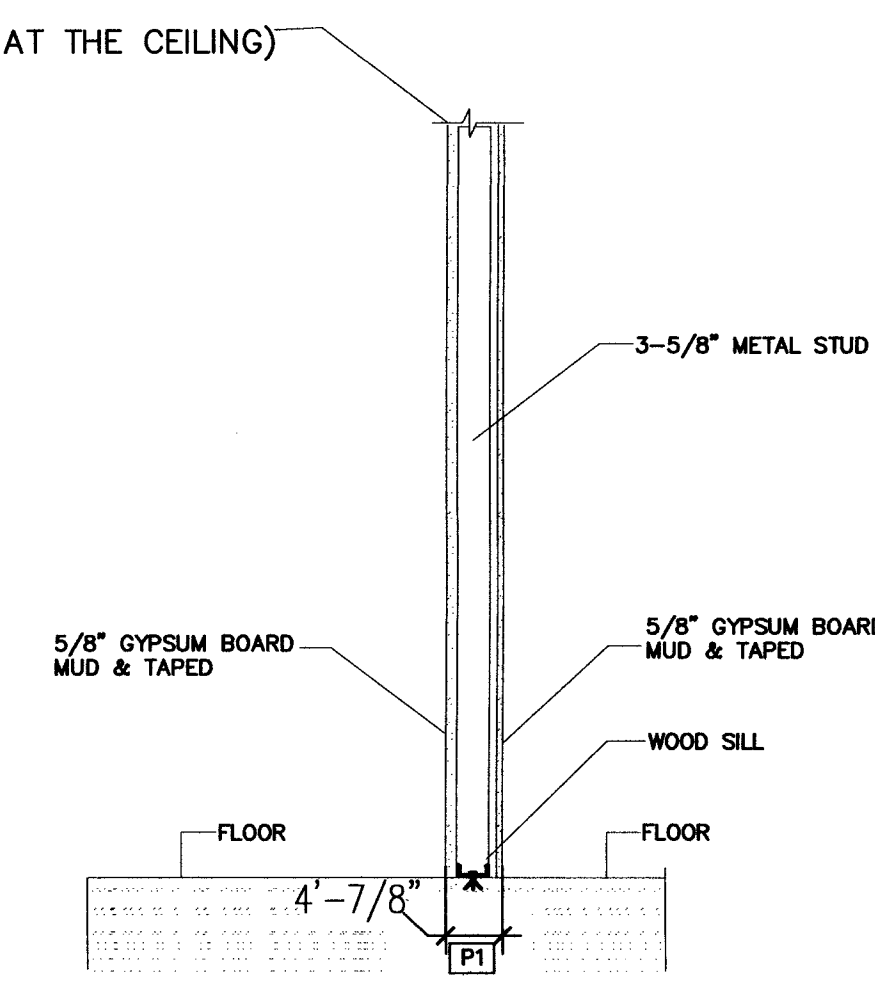

1 INTERIOR DRYWALL BOTH SIDES
N.T.S.

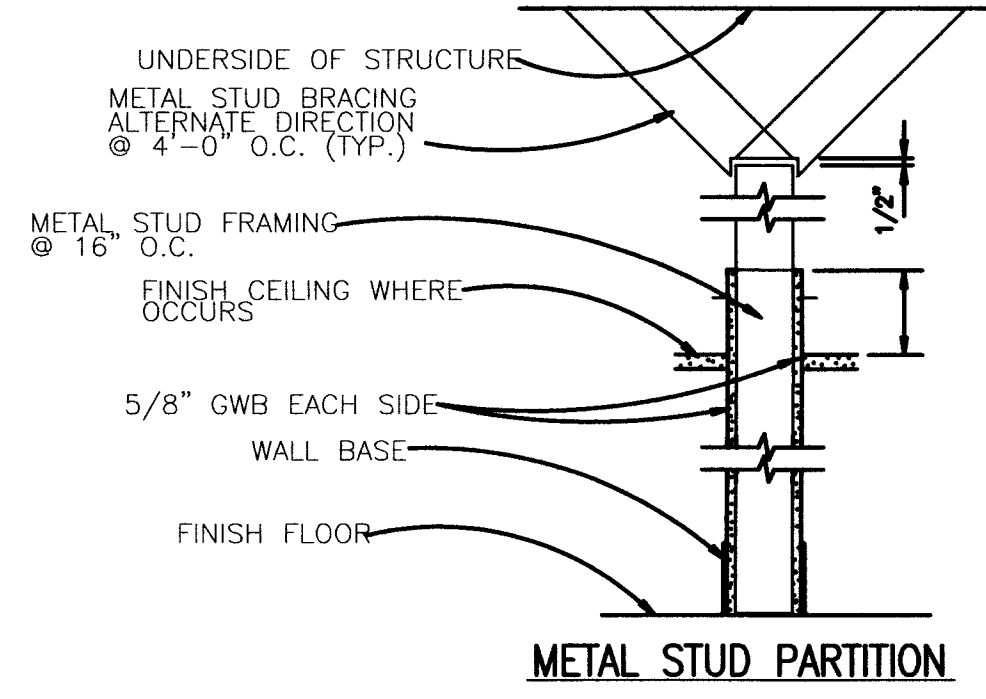

2 PARTITION WALL BRACING
N.T.S.

PERMIT SET FOR CONSTRUCTION

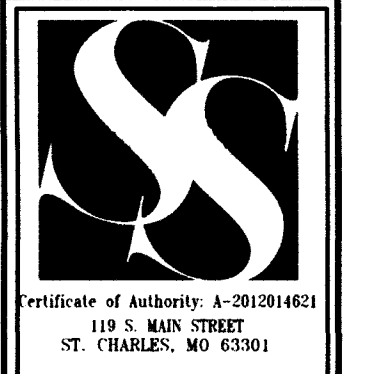

CONSULTANT
DERU & ASSOCIATES, LLC
801 RUE ST. FRANCOIS,
FLORISSANT, MO 63031
CONTACT: JEROME LOGAN
(314) 574-5770 CELL
jlogan@deruassociates.com

PROJECT
NEW BAR AND GRILL
1159 N HWY 67
FLORISSANT, MO 63033

FOR

REVISION	DATE

DATE
AUGUST 12, 2021

JOB NUMBER
DERU0063

DRAWING TITLE

DRAWN BY/ CHECKED BY

DRAWING NUMBER
A1.0

COMMENTS

FOR BUILDING PERMIT APPLICATION
6/2013

CITY OF FLORISSANT

Public Hearing



In accordance with 405.125 of the Florissant Zoning Code a Public Hearing will be held by the City Council of Florissant, MO. in the Council Chambers, 955 rue St. Francois, on Monday, November 8, 2021 at 7:00 p.m. on the following proposition:

To authorize a Special Use Permit to Kingston 10, LLC to allow for the operation of a restaurant/bar for the property located at 1157-1159 N. Hwy 67 in a 'B-3' Extensive Business District. Citizens will have an opportunity to be heard. Anyone with special needs should contact the City Clerk at least 5 days before said public hearing by calling 839-7630 or email kgoodwin@florissantmo.com.

CITY OF FLORISSANT, Karen Goodwin, MMC City Clerk

1 INTRODUCED BY COUNCILMAN EAGAN
2 NOVEMBER 22, 2021

3
4 BILL NO. 9744

ORDINANCE NO.

5
6 **ORDINANCE TO AUTHORIZE A SPECIAL USE PERMIT TO TAMIR**
7 **LLC TO ALLOW FOR THE OPERATION OF A SIT-DOWN, CARRY-**
8 **OUT RESTAURANT FOR THE PROPERTY LOCATED AT 8457 N.**
9 **LINDBERGH.**

10
11 WHEREAS, the Florissant Zoning Ordinance authorizes the City Council of the City of
12 Florissant, by Special Permit, after public hearing thereon, to permit the location and operation
13 of a restaurant in the City of Florissant; and

14 WHEREAS the definition of a restaurant as listed in the Zoning Code is “A building
15 where food and beverages are offered for sale to the public for consumption at tables or counters
16 either inside or outside the building on the lot”: and

17 WHEREAS, an application has been filed by Tamir LLC to allow for the operation of
18 restaurant located at located at 8457 N. Lindbergh, and

19 WHEREAS, the Planning and Zoning Commission at their meeting on November 1,
20 2021, recommended that a Special Permit be granted; and

21 WHEREAS, due notice of public hearing no. 21-11-031 on said application to be held on
22 the 22nd of November, 2021 at 7:00 P.M. by the Council of the City of Florissant was duly
23 published, held and concluded; and

24 WHEREAS, the Council, following said public hearing, and after due and careful
25 consideration, has concluded that the issuance of a Special Permit for a restaurant would be in
26 the best interest of the City of Florissant.

27
28 NOW, THEREFORE, BE IT ORDAINED BY THE COUNCIL OF THE CITY OF
29 FLORISSANT, ST. LOUIS COUNTY, MISSOURI, AS FOLLOWS:

30
31 Section I: A Special Use Permit is hereby granted to Tamir LLC, to allow for a sit-down
32 and carry-out restaurant at 8457 N. Lindbergh in a ‘B-3’ Extensive Business District as shown on
33 plans by Levine Associates dated 10/15/21, subject to the conditions set forth below with these
34 conditions being part of the record:

- 35 1. Add approximately 10 shrubs around the existing pole sign.
36 2. Add landscape screening around the HVAC unit on the south side.

37
38
39
40
41
42
43
44
45
46
47
48
49
50
51
52

Section 2: This ordinance shall become in force and effect immediately upon its passage and approval.

Adopted this ____ day of _____, 2021.

Keith Schildroth
President of the Council

Approved this ____ day of _____, 2021.

Timothy J. Lowery
Mayor, City of Florissant

ATTEST: _____
Karen Goodwin, MPPA/MMC/MRCC
City Clerk

CITY OF FLORISSANT

Public Hearing



In accordance with 405.125 of the Florissant Zoning Code a Public Hearing will be held by the City Council of Florissant, MO. in the Council Chambers, 955 rue St. Francois, on Monday, November 22, 2021 at 7:00 p.m. on the following proposition:

To authorize a Special Use Permit to Tamir LLC to allow for the operation of a sit-down, carry-out restaurant for the property located at 8457 N. Lindbergh in a 'B-3' Extensive Business District. Citizens will have an opportunity to be heard. Anyone with special needs should contact the City Clerk at least 5 days before said public hearing by calling 839-7630 or email kgoodwin@florissantmo.com.

CITY OF FLORISSANT, Karen Goodwin, MMC City Clerk

SPECIAL USE PERMIT APPLICATION
TO THE CITY OF FLORISSANT
PLANNING AND ZONING COMMISSION



City Of Florissant – Public Works
314-839-7648

"Preserve and improve the health, safety, and welfare of our residents, businesses and the general public in the City of Florissant; while at the same time maintaining property values and improving the quality of life in the City of Florissant."

~~PLANNING AND ZONING APPROVAL~~
~~RECOMMENDED APPROVAL~~
PLANNING & ZONING
CHAIRMAN

Council Ward 3 Zoning B-3

Initial Date Petitioner Filed _____
Building Commissioner to complete
ward, zone & date filed

SIGN. [Signature] DATE: 11-1-21

SPECIAL PERMIT FOR Operation of a restaurant

Statement of what permit is being sought. (i.e., special permit for operation of a restaurant).

AMEND SPECIAL PERMIT #- _____ TO ALLOW FOR _____
ordinance # Statement of what the amendment is for.

LOCATION 8457 N Lindbergh Blvd Florissant, MO
Address of property.

1) Comes Now Tamir, LLC A Missouri Limited Liability Company
Enter name of petitioner. If a corporation, state as such. If applicable include DBA (Doing Business As)

and states to the Planning and Zoning Commission that he (she) (they) has (have) the following legal interest in the tract of land located in the City of Florissant, State of Missouri, as described on page 3 of this petition.

Legal interest in the Property) Property Owner
State legal interest in the property. (i.e., owner of property, lease).
Submit copy of deed or lease or letter of authorization from owner to seek a special use.

2) The petitioner(s) further state(s) that the property herein described is presently being used for operation of
a restaurant and that the deed restrictions for the property do not prohibit the use which
would be authorized by said Permit.

3) The petitioner(s) further states (s) that they (he) (she) are submitting a detailed site plan of the proposed or existing development showing location and use of all structures, off-street parking, and all other information required by the Zoning Ordinance or determined necessary by the Building Commissioner.

4) The petitioner(s) further state(s) that (he) (she) (they) shall comply with all of the requirements of the City of Florissant, including setback lines and off- street parking.

5) The petitioner (s) further (represent (s) and warrants (s) that they (he) (she) has (have) not made any arrangement to pay any commission gratuity or consideration, directly or indirectly to any official, employee or appointee of the City of Florissant, with respect to this application.

6) The petitioner(s) further state (s) that the Special Use Permit is sought for the following purposes, and no other, as listed in detail, all activities sought to be covered by the permit (i.e.; operation of a business, approval of building and/or site plans (preliminary and / or final), plan approval for signage, etc.):

7) The petitioner (s) state (s) the following factors and reason to justify the permit:
(If more space is needed, separate sheets maybe attached)

Ahmad A El-Haija _____, adamhaija@yahoo.com (479) 685-4467
PRINT NAME SIGNATURE email and phone

FOR TAMIR, LLC A Missouri Limited Liability Company
(company, corporation, partnership)

Print and sign application. If applicant is a corporation or partnership signature must be a CORPORATE OFFICER or a PARTNER. NOTE: Corporate officer is an individual named in corporate papers.

8) I (we) hereby certify that, as applicant (circle one of the following):

1. I (we) have a legal interest in the herein above described property.

2. I am (we are) the duly appointed agent(s) of the petitioner (s), and that all information given here is true and a statement of fact.

Permission granted by the Petitioner assigning an agent (i.e. Architect) to present this petition in their behalf, to the Commission and/or Council. The petitioner must sign below, and provide contact information:

PRESENTOR SIGNATURE Alvah Levine
ADDRESS 2025 South Brentwood Blvd Suite 101 Saint Louis, MO 63144
STREET CITY STATE ZIP CODE
TELEPHONE / EMAIL (314) 991-5600 , alvah@levinearch.net
BUSINESS

I (we) the petitioner (s) do hereby appoint Alvah Levine AIA Levine Associates Architects as
Print name of agent.
my (our) duly authorized agent to represent me (us) in regard to this petition.

Alvah Levine
Signature of Petitioner authorizing an agent

NOTE: When the petitioner and/or his duly authorized agent appears before the Planning and Zoning Commission and to make a presentation, the same individuals must also appear before the City Council at the Public Hearing to make the presentation and no one else will be permitted to make the presentation to the City Council without authorized approval.

IF DESCRIPTIONS, PLATS OR SURVEYS ARE INACCURATE, OR IF THE PETITION APPLICATION IS NOT CORRECT OR COMPLETE, IT WILL BE RETURNED FOR ADDITIONS OR CORRECTIONS.

REQUIRED INFORMATION

Please mark an "X" in the appropriate type of operation, then fill in applicable section (a), (b) or (c).
Corporations are to submit copy of Missouri corporate papers with registration papers.

1) Type of Operation:
Individual _____ Partnership LLC Corporation _____

(a) If an individual:

- (1) Name and Address _____
- (2) Telephone Number _____
- (3) Business Address _____
- (4) Date started in business _____
- (5) Name in which business is operated if different from (1) _____
- (6) If operating under a fictitious name, provide the name and date registered with the State of Missouri, and a copy of the registration.

(b) If a partnership:

- (1) Names & addresses of all partners See attachment 1-1 _____
- (2) Telephone numbers _____
- (3) Business address _____
- (4) Name under which business is operated _____
- (5) If operating under fictitious name, provide date the name was registered with the State of Missouri, and a copy of the registration.

(c) If a corporation:

- (1) Names & addresses of all partners _____
- (2) Telephone numbers _____
- (3) Business address _____
- (4) State of Incorporation & a photocopy of incorporation papers _____
- (5) Date of Incorporation _____
- (6) Missouri Corporate Number _____
- (7) If operating under fictitious name, provide the name and date registered with the State of Missouri, and a copy of registration. _____
- (8) Name in which business is operated _____
- (9) Copy of latest Missouri Anti-Trust. (annual registration of corporate officers) If the property location is in a strip center, give dimensions of your space under square footage and do not give landscaping Information.

Please fill in applicable information requested. If the property is located in a shopping center, provide the dimensions of the tenant space under square footage and landscaping information may not be required.

Name Tamir, LLC
Address 2359-2369 Scheutz Rd Maryland Heights, MO
Property Owner Tamir, LLC
Location of property 8457 North Lindbergh Blvd Florissant, MO
Dimensions of property 80'-0" x 235'-0"
Property is presently zoned B-3 Extensive Commercial Requests Rezoning To _____
Proposed Use of Property Restaurant
Type of Sign Free Standing, Pole Mounted Height 20'
Type of Construction V-B unprotected frame Number Of Stories one
Square Footage of Building 1,764 sq ft Number of Curb Cuts one existing to remain
Number of Parking Spaces 20 Sidewalk Length existing along street to remain
Landscaping: No. of Trees Entire site paved Diameter _____
No. of Shrubs Entire site paved Size _____
Fence: Type Chain length with vinyl slats Length along north and west property lines Height 6'

PLEASE SUBMIT THE FOLLOWING INFORMATION ON PLANS OR DRAWINGS:

1. Zoning of adjoining properties.
2. Show location of property in relation to major streets and all adjoining properties.
3. Show measurement of tract and overall area of tract.
4. Proposed parking layout and count, parking lighting.
5. Landscaping and trash screening.
5. Location, sizes and elevations of signage.

PROVIDE LEGAL DESCRIPTION OF PROPERTY PERTAINING TO THIS PETITION

(Close legal description with acreage to the nearest tenth of an acre).

Provide a legal description of the property. If part of a shopping center, list address and show part of what shopping center (i.e.: 351 N. Highway 67 part of Florissant Meadows Shopping Center). If property is a single lot, list full written legal description with metes and bounds bearings and dimensions.

Attachment 1-2

PROVIDE LOCATION MAP SHOWING AREA INVOLVING THIS PETITION

Provide a drawing of a location map showing the nearest major intersection.

OFFICE USE ONLY

Date Application reviewed 10/25/21

STAFF REMARKS: see staff report

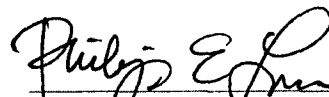

Building Commissioner or Staff Signature

ATTACHMENT 1-1

SPECIAL USE PERMIT APPLICATION
CITY OF FLORISSANT PLANNING AND ZONING COMMISSION

Business Organization:

Name: Tamir, LLC
A Missouri Limited Liability Company

Members: Ahmad A El-Hajja
2359 Schuetz Road
Maryland Heights, MO
(479) 685-4467
Managing Member

Lobna El-Hajja
2359 Schuetz Road
Maryland Heights, MO
(479) 685-4467
Member

Fictitious Name: None Filed

ATTACHMENT 1-2 SPECIAL USE PERMIT APPLICATION
CITY OF FLORISSANT PLANNING AND ZONING COMMISSSION

PURCHASE AND SALE AGREEMENT AND ESCROW INSTRUCTIONS
EXHIBIT "A"
LEGAL DESCRIPTION OF REAL PROPERTY

LOCATION: 8457 N. Lindbergh Blvd.
Florissant, MO 63031

A tract of land in Survey 165 of St. Ferdinand Common Fields, being part of Share 1, as shown on the plat attached to the last Will and Testament of Joseph F. Mottin, deceased, probated in the Probate Court of St. Louis County, Missouri, on July 31, 1899 and described as:

Beginning in the Northwest line of Fee Fee Road, 40 feet wide, at its intersection with the Northeast line of a tract of 7 acres, more or less, conveyed to Joseph E. Creely and wife, by deed recorded in Book 981 page 510 of the St. Louis County Records, thence along Creely's Northeast line, North 53 degrees 05 minutes West, 250 feet to a point, thence North 37 degrees 57 minutes East, 80 feet to a point; thence South 53 degrees 05 minutes East, 250 feet to the Northwest line of Fee Fee Road; thence along the Northwest line of Fee Fee Road, South 37 degrees 57 minutes West, 80 feet to the place of beginning, EXCEPTING that part conveyed to State of Missouri, according to instrument recorded in Book 5983 page 550 of the St. Louis County Records.

1

MEMORANDUM

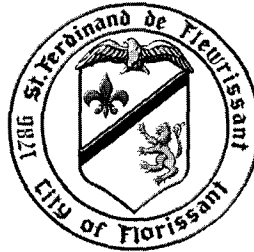

2

CITY OF FLORISSANT- Building Division

3

"Preserve and improve the health, safety, and welfare of our residents, businesses and the general public in the City of Florissant; while at the same time maintaining property values and improving the quality of life in the City of Florissant."

4

5

6

7

To: Planning and Zoning Commissioners Date: October 25, 2021

8

9

From: Philip E. Lum, AIA-Building Commissioner c: Todd Hughes, P.E.,
Director Public Works
Deputy City Clerk
Applicant
File

10

11

12

13

14

15

Subject: Request Recommended Approval of a Special Use Permit at **8457 N. Lindbergh (Tamir LLC)**, to allow for a sit-down, carry out restaurant, in a 'B-3' Extensive Business District.

16

17

18

STAFF REPORT

19

CASE NUMBER PZ-110220-1

20

21

I. PROJECT DESCRIPTION:

22

This is a request for **approval**, to allow for the removal of a roof for de-identification purposes, in a 'B-3' Extensive Business District.

23

24

25

II. EXISTING SITE CONDITIONS:

26

The existing property at 8457 N. Lindbergh is a property which is a 0.43 acre site with a in a 'B-3' Extensive Business District. One year ago, the P&Z Commission approved the removal of a portion of the roof.

27

28

29

The subject property is currently 1548 s.f. and the proposal to remove the metal roof cupola and repaint the remaining roof to de-brand the facility of their trademark roofline was approved one year ago by the P&Z Commission.

30

31

32

33

The existing building was built in 1974 per County record, formerly the Pizza Hut, and operated under Special Use, ord. no. 5695 for the building and no.2451 for the sign, have both expired, precipitating the need for a new Special Use.

34

35

36

37

III. SURROUNDING PROPERTIES:

38

The property to the West is a vacant property 8457-R N. Lindbergh of same width in between this property, and the residence behind ~~X~~ in the 'B-3' Extensive Business

39

40

8457-R

41 District. The property to the north is MAG Automotive at 8461 N. Lindbergh in the 'B-3'
42 Extensive Business District and the property to the South is a Medical Facility at 8457 N.
43 Lindbergh, in a 'B-5' Planned Commercial District.

44
45 **IV. STAFF ANALYSIS:**

46 Plans received from Levine Associates from the applicant include site plan and floor plan
47 dated 10/15/21.

48
49 Comments on the plans:

50 Site Plan:

- 51 • Existing Post sign is adjacent to the front property line and is proposed to remain,
52 was approved as a Special Use, Ord. No. 2451, no longer in use. The sign is 20
53 feet tall and has a square cabinet on top of 44 s.f, per permit record (6'-8"x6'-8")
- 54 • Landscape is non-existent on the site. Since less parking is required, some
55 landscape is possible. Right-of way contains burning bush and one Locust tree.
 - 56 ○ Site requires 2 frontage trees,
 - 57 ○ Perimeter of building would require 37 shrubs.
 - 58 ○ One landscape island dividing 20 parking is required.
- 59 • 8457 Rear is a landlocked lot adjacent to this property is zoned 'B-3' Extensive
60 Business District, therefore this site requires no screen at the rear.
- 61 • Trash screen exists behind the building, proposed to remain as a chain link
62 enclosure with slats.
- 63 • Parking calcs indicate 9 spaces required, 20 shown on plan.
- 64 • Property has been cleaned up recently to expose the chain-link fence at the rear of
65 the property with matching privacy slats, although a screen is not required by
66 code.
- 67 • Parking spaces adjacent to building have been removed to avoid a narrow
68 passage. May be possible to include parallel parking along the north property line.
- 69 • An existing ground mount HVAC unit is visible from the right-of-way which
70 requires at least a 2 sided screen.

71
72 Floor Plan comments

- 73 • Tables and chairs not shown, but noted as a maximum of 10 chairs on the site
74 plan calculations.
- 75 • Noted single restroom is allowable with and occupant load of 15 or fewer.
- 76 • Rear HVAC unit is shown screened with a 6' vinyl fence.
- 77 • Serving window is marked only for walk-up traffic, protected with 2 new bollards
78 and 3 existing bollards.
- 79 • The building is painted along with the metal roofing.
- 80 • Building scales about 29x48.5' = 1406 s.f. with walk up of 48 s.f. and walk-in
81 cooler of 10x19.5' The walk-in cooler is painted to match the painted brick.

82
83 **III. STAFF RECOMENDATIONS:**

84 **Suggested Motion:**

85 I move for of a Special Use Permit at **8457 N. Lindbergh (Tamir LLC)**, to allow for a sit-down
86 and carry out restaurant at 8457 N. Lindbergh in a 'B-3' Extensive Business District as

87 shown on plans by Levine Associates dated 10/15/21, subject to the conditions set forth
88 below with these conditions being part of the record:

- 89 *approx shrubs*
- 90 1. Add a landscape ~~stand~~ *10* in lieu of East ADA space and landscape around the
91 existing sign.
- 92 2. ~~Provide building plantings of 2 shrubs in a landscaped plan for the property as~~
93 ~~approved by the Building Commissioner.~~

94 *3/2 Add landscape screen around unit on S. side*

95

96

97

98 (End of report and suggested motion)

ZONED COMMERCIAL 50' STRIP
 OWNED BY ADJACENT
 RESIDENTIAL NEIGHBOR

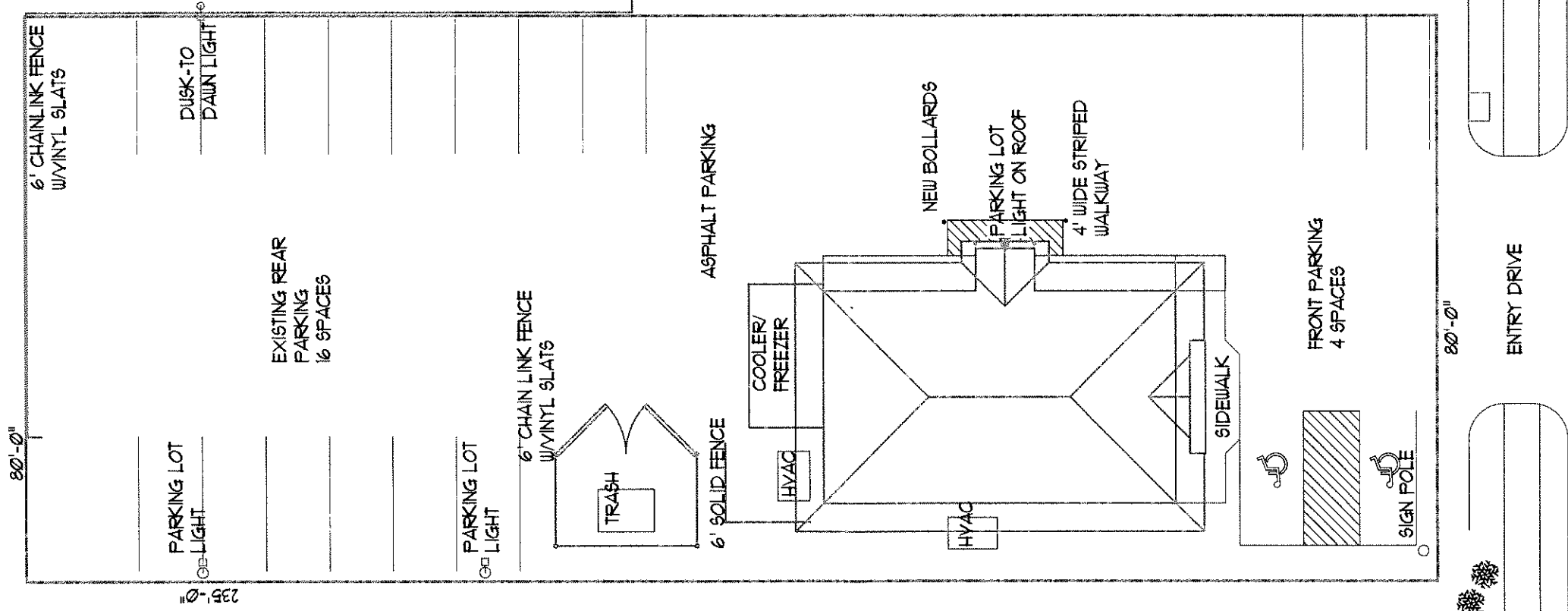

PLANNED
 COMMERCIAL
 (MEDICAL OFFICE)

COMMERCIAL
 (AUTOMOTIVE)

PROJECT DATA
 ZONING DISTRICT:
 B-3 EXTENSIVE COMMERCIAL

BUILDING CODE: 2018 IBC/IEBC

CONSTRUCTION TYPE
 V-B UNPROTECTED FRAME CONSTRUCTION

SITE AREA: 18,800 SF

BUILDING AREA: 11,64 SF

I-STORY

NON-SPRINKLERED

OCCUPANCY TYPE: A-2 RESTAURANT

NUMBER OF OCCUPANTS: (CHAPTER 10)
 CUSTOMER AREA 400 SF / 15 = 27
 KITCHEN 1300 SF / 200 = 6
 TOTAL = 34

ACTUAL NUMBER OF OCCUPANTS: 12

PARKING REQUIRED:
 1/2 SEATS 10 SEATS = 5
 2/3 EMPLOYEES 6 EMPLOYEES = 4
 TOTAL REQUIRED = 9
 TOTAL PROVIDED = 20

OCCUPANCY DRAWING
 BROADWAY GRILL
 8451 LINDBERGH BOULEVARD
 FLORISSANT, MISSOURI 63033

TAMIR LLC, OWNER

PROJECT 2183.01
 10-15-21

SITE PLAN
 SCALE: 1" = 20'-0"

RECOMMENDED APPROVAL
 PLANNING & ZONING
 CHAIRMAN

SIGN:  DATE:

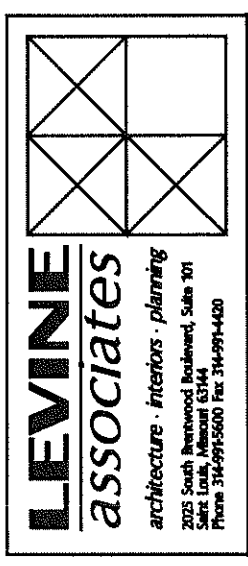

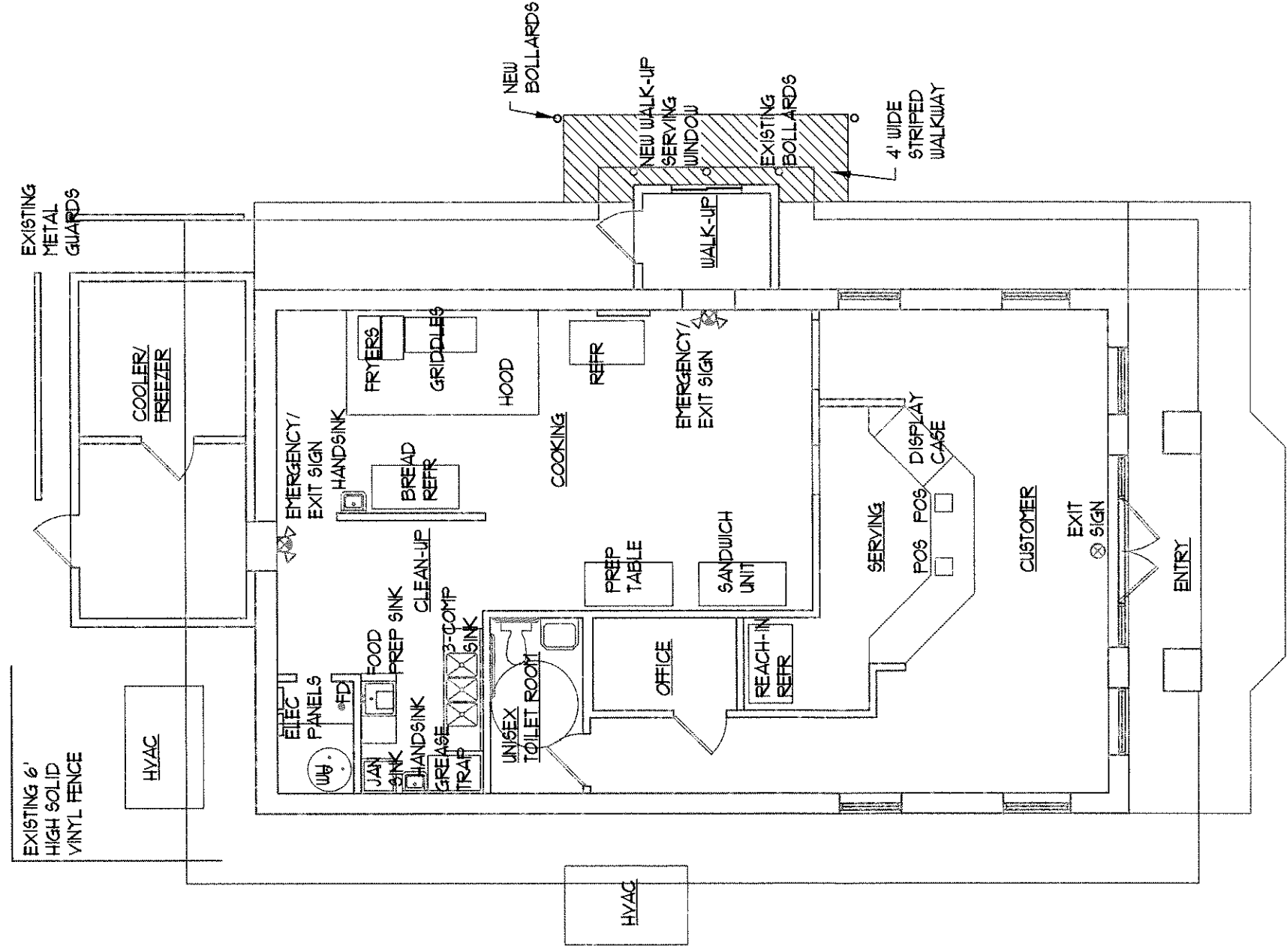

FLOOR PLAN
SCALE: 1/8" = 1'-0"

OCCUPANCY DRAWING
BROADWAY GRILL
8451 LINDBERGH BOULEVARD
FLORISSANT, MISSOURI 63033

TAMIR LLC, OWNER

PROJECT 2183.01
10-15-21

LEVINE
associates
architecture · interiors · planning
2025 South Brentwood Boulevard, Suite 101
Saint Louis, Missouri 63144
Phone 314-991-5600 Fax 314-991-4420

APPLICATION FOR LIQUOR LICENSE

- Full Liquor by the Drink \$450
- Full Package Liquor \$150
- Full Liquor by Drink (Non-Profit) \$300
- Malt Liquor & Wine by the Drink \$75.00
- Malt Liquor & Wine Package \$75
- Tasting \$37.50

To the City Clerk, City of Florissant, St. Louis County, Missouri:

The undersigned hereby makes application for the renewal of liquor license issued under Chapter 600 of the Florissant Code of Ordinances.

Type of License Requested:

- Individual
- Corporation (Attach list of Officers, Addresses, & Phone Numbers)
- Limited Liability
- Partnership (Attach list of partners)

Name of **Business**: Kingston 10 Phone: 314 458 6005

Business Address: 1157-59 North Highway 67 Email: Detrest@Aol.com

Names of **Applicant, Corp., or LLC**: Kingston 10 LLC

Address of Owner: 12521 Evening Shade No 63033 Phone: 314 458 6005
Street City State Zip

Name of **Managing Officer**: Dean Treston

Home Address: 12521 Evening Shade or Black Sack Mo 63033 Years at Address: 18 yrs
Street City State Zip

Managing Officer: Date of Birth: 4-7-71 Cell Phone: 314 458 6005

Driver's License No. [Redacted]
(Provide photo copy)

Social Security No.* [Redacted]
*for identification in running record check

Email: Detrest@Aol.com

Managing Officer: Personal Property Taxes 2020 Paid? Yes No (Attached recent)

Registered Voter of Missouri? Yes No **Attach Voter Registration Certificate

Have you ever been arrested? yes What Charge? Distribution

Where? St Louis County Disposition? Syrs Probation 2003

Citizen of U.S.A.? Yes No Naturalized? Yes Date 3-6-1998 No

If Naturalized, Give Number: [REDACTED] Dist. Eastern Dist of Missouri
(Provide Documents)

Do you have an interest in any liquor license which is now in force? Yes No

Give details: _____

Have you prev. held a liquor license of this type? Yes No

If so, when & where? _____

Have you ever had a liquor license suspended or revoked? Yes No

Give details: _____

Have you ever been convicted of any violation of any federal or state law? Yes No

Give details: Distribution _____

Have you ever been convicted of any violation of any federal law, state statute, or local ordinance relating to intoxication? Yes No

Give details: _____

Has the location previously been occupied as a liquor establishment, liquor store, or tavern?
 Yes No

Provide name: _____

Is the location within 200 feet of property used for church, school, or public playground? Yes No

If Individual Applicant:

If Partnership, Corp., or LLC, complete below:

Kingston LLC
Trade Name

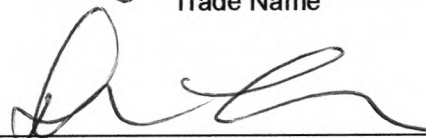
Signature of Managing Officer

STATE OF MISSOURI) SS
COUNTY OF ST. LOUIS)

DT

Oct

Dean Weston, of lawful age, being first duly sworn upon Sept 6th 2021
(Individual or Managing Officer)

Deposes and states that he/she is the (applicant) (the managing officer of the corporation or partnership seeing the license hereunder), that he/she has read this application and fully understands same, that said license will be subject to all of the ordinances of the City pertaining to the operation of said business and agrees that he will abide by all lawful ordinances, regulations, and rules adopted by the City relation to the conduct of said business, that he is in all respect qualified in law to receive such license, and that the answers and statements set out in the above application are true.

[Signature]
Signature of Individual or Managing Officer

Subscribed and sworn to before me this 6 day of October, 2021.

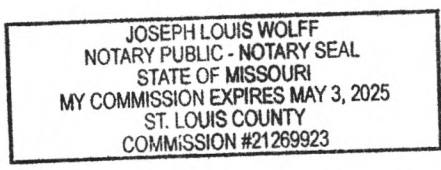

[Signature]
Notary Public

My Commission Expires: 5-3-2025

APPLICATION MUST BE SWORN TO BEFORE A PUBLIC NOTARY.

SUPPLEMENT TO APPLICATION FOR LIQUOR LICENSE
CORPORATION & LIMITED LIABILITY COMPANY:

Copy of Certification of Incorporation/Registration &
Articles of Organization papers must be attached

To the Florissant City Council, Florissant, St. Louis County, Missouri _____

Date _____

**TO BE COMPLETED BY ALL PARTNERS, OR IF CORPORATION OR LIMITED LIABILITY
CORPORATION BY ALL OFFICERS OR MEMBERS:**

1. FULL NAME: Dean Treston
SOC. SEC. NO. [REDACTED] SEX: Male
DATE OF BIRTH: 4-7-71 PLACE OF BIRTH: Kingston Jamaica
PHONE NUMBER: 314 458 6005
ADDRESS: 12521 Evening Shade Dr Black Jack MO 63033
LAST PREV. ADDRESS: 10 Estrada Dr Spanish lake 63138
NO. OF YEARS AT ADDRESS: 6 yrs

2. FULL NAME: _____
SOC. SEC. NO. _____ SEX: _____
DATE OF BIRTH: _____ PLACE OF BIRTH: _____
PHONE NUMBER: _____
ADDRESS: _____
LAST PREV. ADDRESS: _____
NO. OF YEARS AT ADDRESS: _____

3. FULL NAME: _____
SOC. SEC. NO. _____ SEX: _____
DATE OF BIRTH: _____ PLACE OF BIRTH: _____
PHONE NUMBER: _____
ADDRESS: _____
LAST PREV. ADDRESS: _____
NO. OF YEARS AT ADDRESS: _____

PLEASE FILL OUT THIS FORM AND RETURN WITH YOUR LICENSE APPLICATION

In order for the Police Department to provide you with the best possible service, it is necessary for them to have certain information concerning your business:

EMERGENCY CONTACT INFORMATION

OWNER OF PROPERTY Terry Tatum PHONE 314 497 2219
ADDRESS 537 Treetop Village Ballwin Mo 63021
NAME OF BUSINESS Kingston 10 PHONE 314 458 6005
ADDRESS 1157-59 North Highway 67 Florissant MO. 63031
BUSINESS HOURS 11am - 11pm Tues - Thurs, 11am - 1am Fri - Sat, 11am - 10pm Sun
OWNER/MANAGER Dean Treston PHONE 314 458 6005
HOME ADDRESS 12521 Evening Shade Dr Black Jack Mo 63033

PLEASE LIST PERSONS TO BE CONTACTED AFTER BUSINESS HOURS IN CASE OF AN EMERGENCY OR IF THERE IS A DOOR OR WINDOW FOUND INSECURE.

CONTACT #1 HAS KEY YES NO
NAME Dean Treston ADDRESS 12521 Evening Shade
CITY & STATE Black Jack Mo PHONE 314 458 6005

CONTACT #2 HAS KEY YES NO
NAME Terry Tatum ADDRESS 537 Treetop Village
CITY & STATE Ballwin Mo PHONE 314 497 2219

ARE THERE LIGHTS LEFT ON AFTER HOURS? YES NO
IS ANYONE AUTHORIZED TO BE ON THE PREMISES AFTER BUSINESS HOURS? YES NO

IF YES, WHO? _____
ARE ANY VEHICLES PARKED AT YOUR BUSINESS AFTER HOURS? YES NO

DESCRIBE: _____
(YEAR) (MAKE/MODEL) (COLOR) (LICENSE NO.)

DO YOU HAVE A SAFE OF ANY KIND? YES NO

WHERE IS IT LOCATED? _____

CAN IT BE SEEN FROM THE OUTSIDE? YES NO N/A

IS YOUR BUSINESS PROTECTED WITH AN ALARM SYSTEM? YES NO

IF AT ANY TIME THERE IS A CHANGE IN THE ABOVE INFORMATION, PLEASE NOTIFY THE POLICE DEPARTMENT IMMEDIATELY, ESPECIALLY IN THE CASE OF THOSE PERSONS TO NOTIFY IN CASE OF AN EMERGENCY. THANK YOU.

CITY OF FLORISSANT



FLORISSANT, MISSOURI

WAIVER

Authorization to complete record check

I, Dean Treston, RESIDING AT

12521 Evening Shade Dr IN THE

CITY OF Black Jack STATE OF

Missouri

I do hereby authorize the City Clerk of the City of Florissant, Missouri to make a full and complete check of my record in the Metropolitan St. Louis area, state of Missouri, all prior areas of residence, and through the National Criminal Information Center in Washington, D.C.

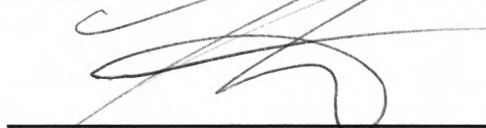

Witness



Signature

10/6/21

Date

4-7-71

Date of Birth



Social Security Number**



Driver's License No. & State

**Social Security Number and Driver's License Numbers will be used for the purpose of identification in completing record check.

**APPLICATION FOR SUNDAY LIQUOR LICENSE
TO THE CITY CLERK, CITY OF FLORISSANT, SAINT LOUIS COUNTY, MISSOURI**

Authorizing the sale of retail liquor by the drink or package in the City of Florissant on **SUNDAY** from 9:00 am to midnight.

TYPE OF OPERATION:

Individual Partnership Corporation Limited Liability Corp

NAME OF BUSINESS Kingston 10

LOCATION 1157-59 North Highway 67 **PHONE** 314 458 6005

EXACT TRADE NAME, LLC, OR CORP Kingston 10 LLC

The undersigned (Individual, Partnership, Corporation, LLC), hereby makes application to the City Clerk, City of Florissant, St. Louis County, Missouri for a "By the Drink/Package Liquor License" authorizing the sale of retail liquor on Sundays from 9:00 am to midnight for the period beginning on Nov 2021 and expiring on June 30, 2022, on the above described premises and agrees that if the license herein applied for is granted, and the licensee shall violate any provisions of the State Liquor Control Act or of the City of Florissant Code and particularly any provision of Chapter 600 of the Florissant City Code pertaining to alcoholic beverages or permit any other person to do so upon the licensed premises, the City Council, by a majority vote, may suspend or revoke such license.

1. I/WE presently hold Florissant License Number N/A authorizing the sale of retail liquor by the drink or package in Florissant for premises described in this application.

STATE OF MISSOURI)SS
COUNTY OF ST. LOUIS)

I Dean Treston of lawful age, being first duly sworn upon my oath, depose and say that I (Print name of Managing Officer) have read this application and that I fully understand the same; that I know the contents thereof and the statements contained therein and that the same are true of my own knowledge.

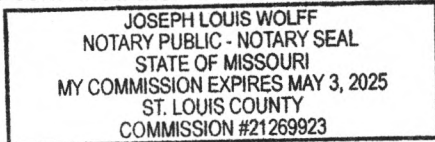

[Signature]
Signature of Individual or Managing Officer

Subscribed and sworn to before me this 6 day of 2021.

My Commission Expires: 5-3-2025

[Signature]
Notary Public



No Match Notification

A statewide search of the identifiers below has revealed no criminal conviction or sex offender information on file. Fingerprints were not provided and thus the result of the search cannot be guaranteed.

Date of Search: 10/06/2021

Name (1): DEAN TRESTON

Name (2):

Name (3):

Date Of Birth: 04/07/1974

SSN: xxx-xx-8270

Control Number: 5708991

If you have any questions, please do not hesitate to contact our office at 573-526-6153.

Missouri State Highway Patrol
Criminal Justice Information Services Division
PO BOX 9500
Jefferson City, MO 65102

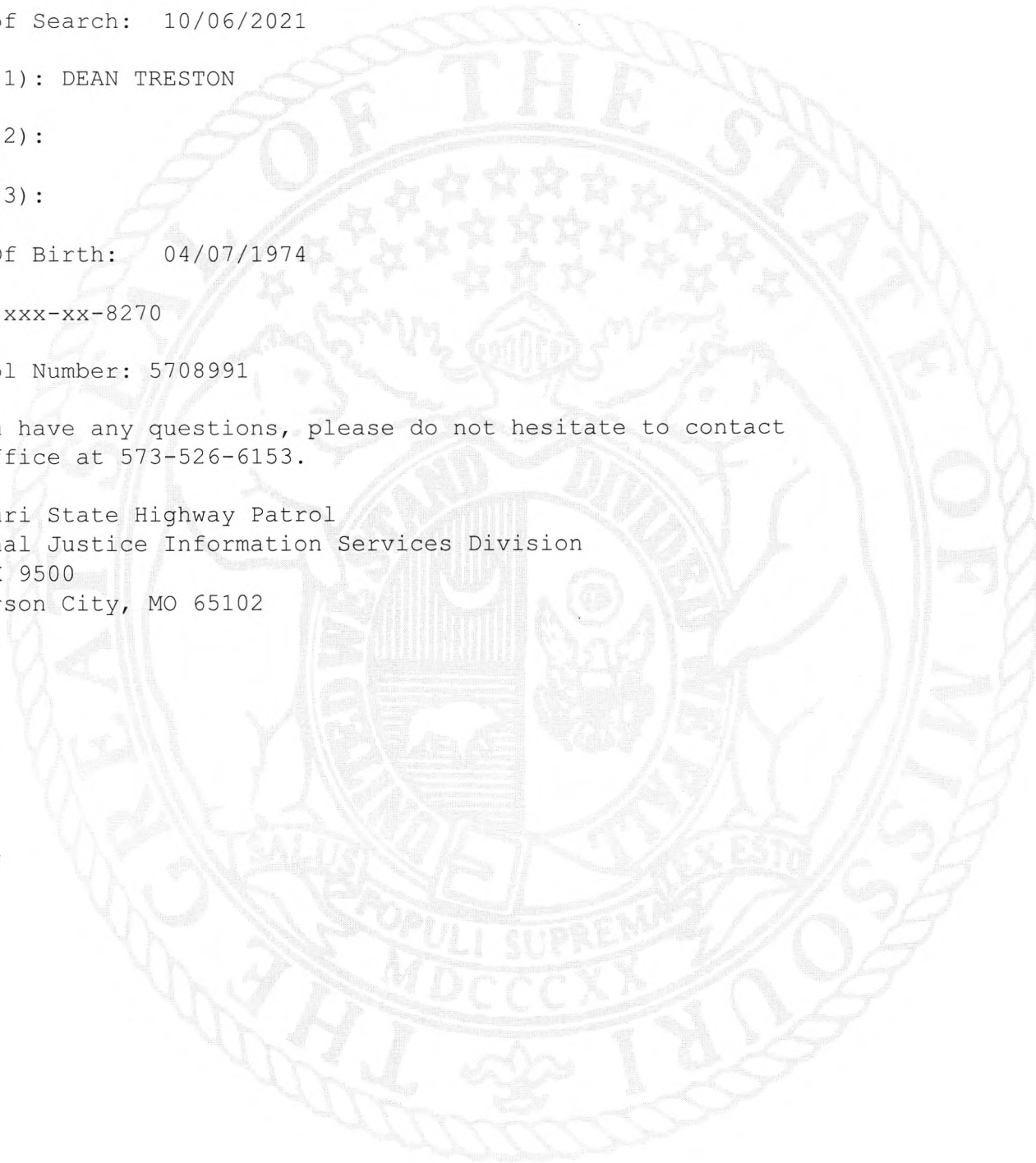

APPLICATION FOR LIQUOR LICENSE

Full Liquor by the Drink \$450

Malt Liquor & Wine by the Drink \$75.00

Full Package Liquor \$150

Malt Liquor & Wine Package \$75

Full Liquor by Drink (Non-Profit) \$300

Tasting \$37.50

To the City Clerk, City of Florissant, St. Louis County, Missouri:

The undersigned hereby makes application for the renewal of liquor license issued under Chapter 600 of the Florissant Code of Ordinances.

Type of License Requested:

Individual

Corporation (Attach list of Officers, Addresses, & Phone Numbers)

Limited Liability

Partnership (Attach list of partners)

Name of **Business**: Plush Lounge Phone: 217-556-6068

Business Address: 12667 New Halls ferry Email: PKoroma23@gmail.com

Names of **Applicant, Corp., or LLC**: Plush hookah LLC

Address of Owner: 1675 Verlene Dr. Florissant, 63031 Phone: 217-556-6068
Street City State Zip

Name of **Managing Officer**: Princee Koroma

Home Address: 1675 Verlene Dr. Florissant 63031 Years at Address: 5 yrs
Street City State Zip

Managing Officer: Date of Birth: 01-01-1990 Cell Phone: 217-556-6068

Driver's License No. T059331003
(Provide photo copy)

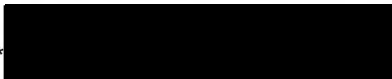
Social Security No.* 
*for identification in running record check

Email: PKoroma23@gmail.com

Managing Officer: Personal Property Taxes 20__ Paid? Yes No (Attached recent)

Registered Voter of Missouri? Yes No **Attach Voter Registration Certificate

Have you ever been arrested? No What Charge? None

Where? _____ Disposition? _____

Citizen of U.S.A.? Yes No Naturalized? Yes Date _____ No

If Naturalized, Give Number: _____ Dist. _____
(Provide Documents)

Do you have an interest in any liquor license which is now in force? Yes No

Give details: _____

Have you prev. held a liquor license of this type? Yes No

If so, when & where? _____

Have you ever had a liquor license suspended or revoked? Yes No

Give details: _____

Have you ever been convicted of any violation of any federal or state law? Yes No

Give details: _____

Have you ever been convicted of any violation of a federal law, state statute, or local ordinance relating to intoxication? () Yes () No

Give details: _____

Has the location previously been occupied as a liquor establishment, liquor store, or tavern?
 Yes No

Provide name: Jay's ultra lounge

Is the location within 200 feet of property used for church, school, or public playground? Yes No

If Individual Applicant:

If Partnership, Corp., or LLC, complete below:
Plush Hookah LLC
Trade Name

[Signature]
Signature of Managing Officer

STATE OF MISSOURI) SS
COUNTY OF ST. LOUIS)

_____, of lawful age, being first duly sworn upon _____
(Individual or Managing Officer)

Deposes and states that he/she is the (applicant) (the managing officer of the corporation or partnership seeing the license hereunder), that he/she has read this application and fully understands same, that said license will be subject to all of the ordinances of the City pertaining to the operation of said business and agrees that he will abide by all lawful ordinances, regulations, and rules adopted by the City relation to the conduct of said business, that he is in all respect qualified in law to receive such license, and that the answers and statements set out in the above application are true.

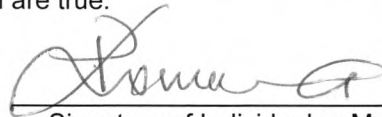

Signature of Individual or Managing Officer

Subscribed and sworn to before me this 18 day of Oct Nov., 2021.

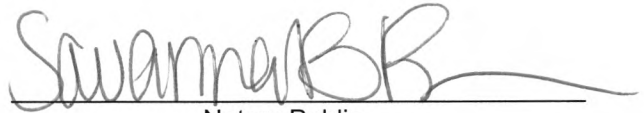

Notary Public

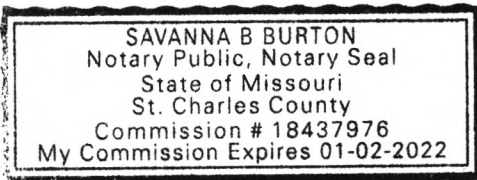

My Commission Expires: 01-02-2022

APPLICATION MUST BE SWORN TO BEFORE A PUBLIC NOTARY.

SUPPLEMENT TO APPLICATION FOR LIQUOR LICENSE

CORPORATION & LIMITED LIABILITY COMPANY:

Copy of Certification of Incorporation/Registration &
Articles of Organization papers must be attached

To the Florissant City Council, Florissant, St. Louis County, Missouri _____

Date _____

TO BE COMPLETED BY ALL PARTNERS, OR IF CORPORATION OR LIMITED LIABILITY CORPORATION BY ALL OFFICERS OR MEMBERS:

1. FULL NAME: Prince Koroma
SOC. SEC. NO. [REDACTED] SEX: male
DATE OF BIRTH: 01-01-1990 PLACE OF BIRTH: Sierra Leone
PHONE NUMBER: 217-556-6068
ADDRESS: 1675 Verlene Dr. Florissant, MO 63031
LAST PREV. ADDRESS: 759 W. Canterbury Rd St. Louis MO
NO. OF YEARS AT ADDRESS: _____

2. FULL NAME: _____
SOC. SEC. NO. _____ SEX: _____
DATE OF BIRTH: _____ PLACE OF BIRTH: _____
PHONE NUMBER: _____
ADDRESS: _____
LAST PREV. ADDRESS: _____
NO. OF YEARS AT ADDRESS: _____

3. FULL NAME: _____
SOC. SEC. NO. _____ SEX: _____
DATE OF BIRTH: _____ PLACE OF BIRTH: _____
PHONE NUMBER: _____
ADDRESS: _____
LAST PREV. ADDRESS: _____
NO. OF YEARS AT ADDRESS: _____

PLEASE FILL OUT THIS FORM AND RETURN WITH YOUR LICENSE APPLICATION

In order for the Police Department to provide you with the best possible service, it is necessary for them to have certain information concerning your business:

EMERGENCY CONTACT INFORMATION

OWNER OF PROPERTY _____ PHONE _____

ADDRESS _____

NAME OF BUSINESS _____ PHONE _____

ADDRESS _____

BUSINESS HOURS _____

OWNER/MANAGER _____ PHONE _____

HOME ADDRESS _____

PLEASE LIST PERSONS TO BE CONTACTED AFTER BUSINESS HOURS IN CASE OF AN EMERGENCY OR IF THERE IS A DOOR OR WINDOW FOUND INSECURE.

CONTACT #1 HAS KEY YES NO
NAME Prince Koroma ADDRESS 1675 Verlene Drive
CITY & STATE Florissant, MO PHONE 217-556-6868

CONTACT #2 HAS KEY YES NO
NAME _____ ADDRESS _____
CITY & STATE _____ PHONE _____

ARE THERE LIGHTS LEFT ON AFTER HOURS? YES NO
IS ANYONE AUTHORIZED TO BE ON THE PREMISES AFTER BUSINESS HOURS? YES NO

IF YES, WHO? Cleaning staff & managing Officer
ARE ANY VEHICLES PARKED AT YOUR BUSINESS AFTER HOURS? YES NO

DESCRIBE: 2005 Infiniti Gold
(YEAR) (MAKE/MODEL) (COLOR) (LICENSE NO.)

DO YOU HAVE A SAFE OF ANY KIND? YES NO
WHERE IS IT LOCATED? Office

CAN IT BE SEEN FROM THE OUTSIDE? YES NO

IS YOUR BUSINESS PROTECTED WITH AN ALARM SYSTEM? YES NO

IF AT ANY TIME THERE IS A CHANGE IN THE ABOVE INFORMATION, PLEASE NOTIFY THE POLICE DEPARTMENT IMMEDIATELY, ESPECIALLY IN THE CASE OF THOSE PERSONS TO NOTIFY IN CASE OF AN EMERGENCY. THANK YOU.



No Match Notification

A statewide search of the identifiers below has revealed no criminal conviction or sex offender information on file. Fingerprints were not provided and thus the result of the search cannot be guaranteed.

Date of Search: 11/17/2021

Name (1): PRINCE KOROMA

Name (2):

Name (3):

Date Of Birth: 01/01/1990

SSN: xxx-xx-1354

Control Number: 5762083

If you have any questions, please do not hesitate to contact our office at 573-526-6153.

Missouri State Highway Patrol
Criminal Justice Information Services Division
PO BOX 9500
Jefferson City, MO 65102

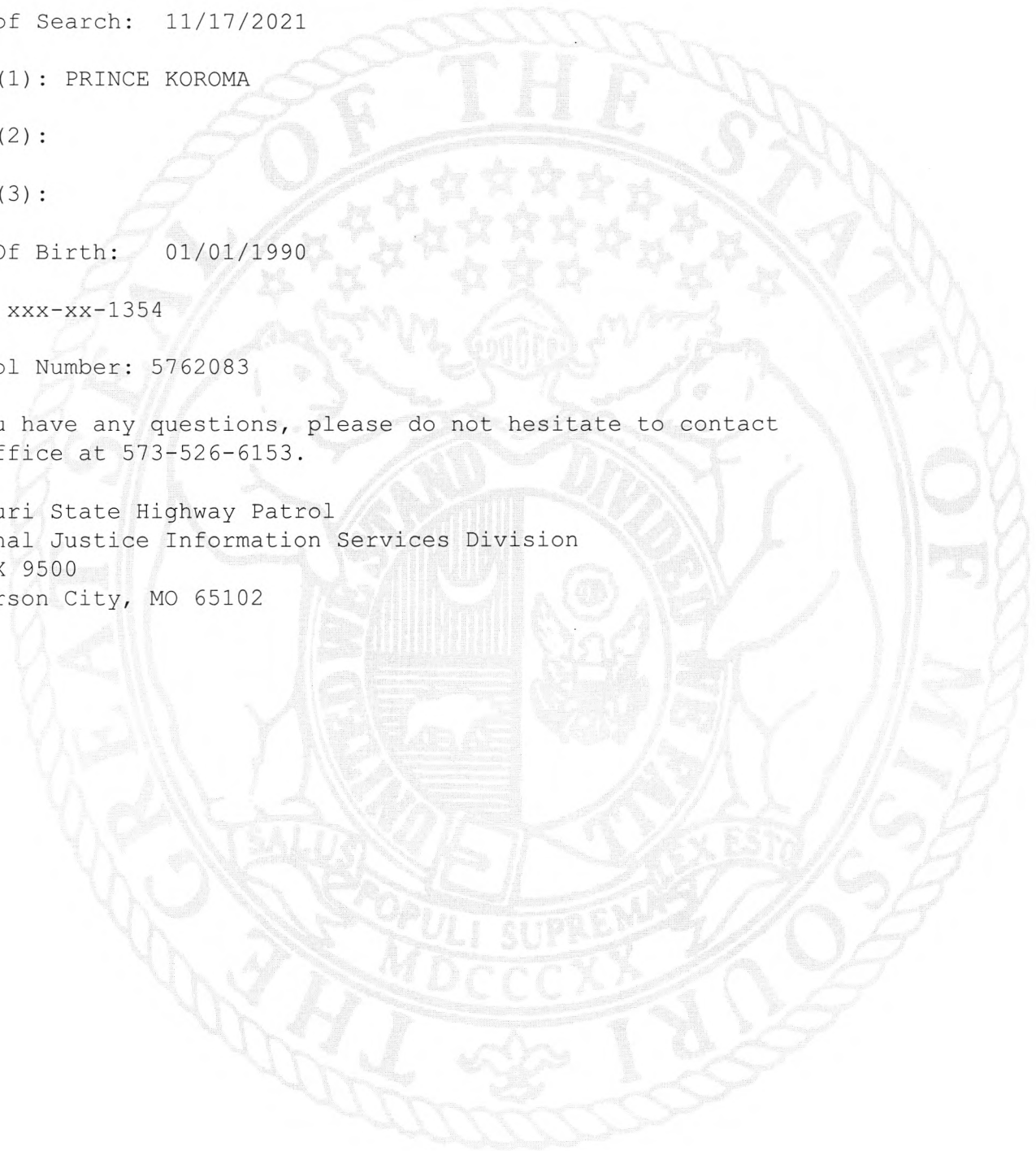

CITY OF FLORISSANT



FLORISSANT, MISSOURI

WAIVER

Authorization to complete record check

I, Prince M. Koroma, RESIDING AT

1675 Verlene Drive IN THE

CITY OF Florissant. STATE OF

MISSOURI

I do hereby authorize the City Clerk of the City of Florissant, Missouri to make a full and complete check of my record in the Metropolitan St. Louis area, state of Missouri, all prior areas of residence, and through the National Criminal Information Center in Washington, D.C.

[Handwritten Signature]

Witness

[Handwritten Signature]

Signature

11-17-21

Date

01-01-1990

Date of Birth

[Redacted]

Social Security Number**

T059331003 & MO

Driver's License No. & State

**Social Security Number and Driver's License Numbers will be used for the purpose of identification in completing record check.

APPLICATION FOR SUNDAY LIQUOR LICENSE
TO THE CITY CLERK, CITY OF FLORISSANT, SAINT LOUIS COUNTY, MISSOURI

Authorizing the sale of retail liquor by the drink or package in the City of Florissant on **SUNDAY** from 9:00 am to midnight.

TYPE OF OPERATION:

Individual Partnership Corporation Limited Liability Corp

NAME OF BUSINESS Plush Lounge

LOCATION 12667 New halls ferry **PHONE** 217 - 556 - 6068

EXACT TRADE NAME, LLC, OR CORP Plush Hookah LLC

The undersigned (Individual, Partnership, Corporation, LLC), hereby makes application to the City Clerk, City of Florissant, St. Louis County, Missouri for a "By the Drink/Package Liquor License" authorizing the sale of retail liquor on Sundays from 9:00 am to midnight for the period beginning on _____ and expiring on June 30, 20____, on the above described premises and agrees that if the license herein applied for is granted, and the licensee shall violate any provisions of the State Liquor Control Act or of the City of Florissant Code and particularly any provision of Chapter 600 of the Florissant City Code pertaining to alcoholic beverages or permit any other person to do so upon the licensed premises, the City Council, by a majority vote, may suspend or revoke such license.

- 1. I/WE presently hold Florissant License Number _____ authorizing the sale of retail liquor by the drink or package in Florissant for premises described in this application.

STATE OF MISSOURI)SS
COUNTY OF ST. LOUIS)

I _____ of lawful age, being first duly sworn upon my oath, depose and say that I (Print name of Managing Officer) have read this application and that I fully understand the same; that I know the contents thereof and the statements contained therein and that the same are true of my own knowledge.

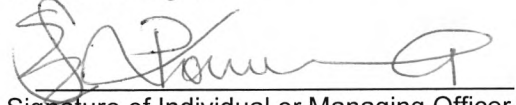
Signature of Individual or Managing Officer

Subscribed and sworn to before me this 18/NOV day of 2021.

My Commission Expires: 01-02-2022

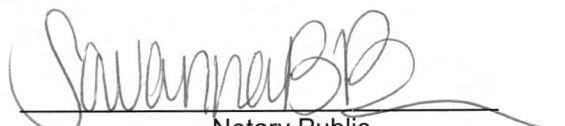
Notary Public

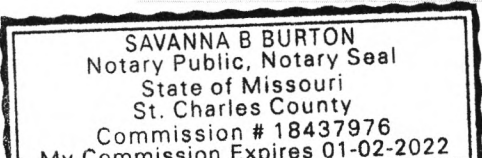

APPLICATION FOR LIQUOR LICENSE

- | | |
|--|---|
| <input checked="" type="checkbox"/> Full Liquor by the Drink \$450 | <input checked="" type="checkbox"/> Malt Liquor & Wine by the Drink \$75.00 |
| <input type="checkbox"/> Full Package Liquor \$150 | <input type="checkbox"/> Malt Liquor & Wine Package \$75 |
| <input type="checkbox"/> Full Liquor by Drink (Non-Profit) \$300 | <input type="checkbox"/> Tasting \$37.50 |

To the City Clerk, City of Florissant, St. Louis County, Missouri:
The undersigned hereby makes application for the renewal of liquor license issued under Chapter 600 of the Florissant Code of Ordinances.

Type of License Requested:

- | | |
|---|--|
| <input type="checkbox"/> Individual | <input type="checkbox"/> Corporation (Attach list of Officers, Addresses, & Phone Numbers) |
| <input checked="" type="checkbox"/> Limited Liability | <input type="checkbox"/> Partnership (Attach list of partners) |

Name of **Business**: Henkes Tavern Phone: 314-323-7176

Business Address: 901 N. Lafayette Email: mgoldstein2goldmarkent.com

Names of **Applicant, Corp., or LLC**: FloMO LLC

Address of Owner: 549 N. Lafayette Florissant, MO 63031 Phone: 314-921-2323
Street City State Zip

Name of **Managing Officer**: Mark Goldstein

Home Address: 540 Rue St. Antoine, Florissant, MO 63031 Years at Address: 20
Street City State Zip

Managing Officer: Date of Birth: 05/13/1967 Cell Phone: 314-323-7176

Driver's License No. [REDACTED] Social Security No.* [REDACTED]
(Provide photo copy) *for identification in running record check
Email: mgoldstein@goldmarkent.com

Managing Officer: Personal Property Taxes 2020. Paid? Yes No (Attached recent)

Registered Voter of Missouri? Yes No **Attach Voter Registration Certificate

Have you ever been arrested? no What Charge? no

Where? no Disposition? no

Citizen of U.S.A.? Yes No Naturalized? Yes Date _____ No

If Naturalized, Give Number: _____ Dist. _____
(Provide Documents)

Do you have an interest in any liquor license which is now in force? Yes No

Give details: _____

Have you prev. held a liquor license of this type? Yes No

If so, when & where? _____

Have you ever had a liquor license suspended or revoked? Yes No

Give details: _____

Have you ever been convicted of any violation of any federal or state law? Yes No

Give details: _____

Have you ever been convicted of any violation of a federal law, state statute, or local ordinance relating to intoxication? Yes No

Give details: _____

Has the location previously been occupied as a liquor establishment, liquor store, or tavern?
 Yes No

Provide name: _____

Is the location within 200 feet of property used for church, school, or public playground? Yes No

If Individual Applicant:

If Partnership, Corp., or LLC, complete below:
Flo Mo LLC

Trade Name

Mark [Signature] Managing Partner
Signature of Managing Officer

STATE OF MISSOURI) SS
COUNTY OF ST. LOUIS)

Mark Goldstein _____, of lawful age, being first duly sworn upon _____
(Individual or Managing Officer)

Deposes and states that he/she is the (applicant) (the managing officer of the corporation or partnership seeing the license hereunder), that he/she has read this application and fully understands same, that said license will be subject to all of the ordinances of the City pertaining to the operation of said business and agrees that he will abide by all lawful ordinances, regulations, and rules adopted by the City relation to the conduct of said business, that he is in all respect qualified in law to receive such license, and that the answers and statements set out in the above application are true.

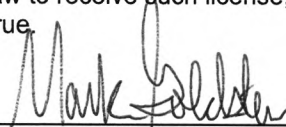

Signature of Individual or Managing Officer

Subscribed and sworn to before me this 30 day of November, 2021.



Notary Public

My Commission Expires: 01-02-2022

APPLICATION MUST BE SWORN TO BEFORE A PUBLIC NOTARY.

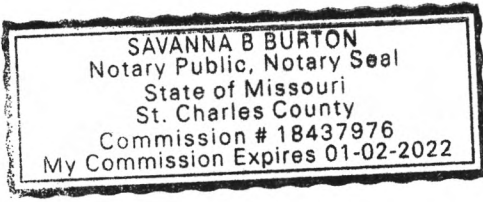

SUPPLEMENT TO APPLICATION FOR LIQUOR LICENSE

CORPORATION & LIMITED LIABILITY COMPANY:

Copy of Certification of Incorporation/Registration &
Articles of Organization papers must be attached

To the Florissant City Council, Florissant, St. Louis County, Missouri _____

Date 11/30/21

TO BE COMPLETED BY ALL PARTNERS, OR IF CORPORATION OR LIMITED LIABILITY CORPORATION BY ALL OFFICERS OR MEMBERS:

1. FULL NAME: Mark Goldstein
SOC. SEC. NO. [REDACTED] SEX: male
DATE OF BIRTH: 05/13/1967 PLACE OF BIRTH: Florissant
PHONE NUMBER: 314-323-7176
ADDRESS: 540 Rue St. Antoine, Florissant, MO 63031
LAST PREV. ADDRESS: 865 Washington, Florissant, MO 63031
NO. OF YEARS AT ADDRESS: 20
2. FULL NAME: Joseph R. Meyer
SOC. SEC. NO. [REDACTED] SEX: Male
DATE OF BIRTH: 8/07/1988 PLACE OF BIRTH: St. Louis
PHONE NUMBER: 314-495-5725
ADDRESS: 985 St. Joseph Street, Florissant, MO 63031
LAST PREV. ADDRESS: 1840 St. Marie, Florissant, MO 63031
NO. OF YEARS AT ADDRESS: 8
3. FULL NAME: Gary R. Meyer
SOC. SEC. NO. [REDACTED] SEX: M
DATE OF BIRTH: 12/24/61 PLACE OF BIRTH: Florissant
PHONE NUMBER: 314-853-6876
ADDRESS: 905 Rue St. Antoine Street, Florissant, Mo. 63031
LAST PREV. ADDRESS: _____
NO. OF YEARS AT ADDRESS: _____

PLEASE FILL OUT THIS FORM AND RETURN WITH YOUR LICENSE APPLICATION

In order for the Police Department to provide you with the best possible service, it is necessary for them to have certain information concerning your business:

EMERGENCY CONTACT INFORMATION

OWNER OF PROPERTY Mark Goldstein PHONE 314-323-7176
ADDRESS 540 Rue St. Antoine, Florissant, MO 63031
NAME OF BUSINESS Henkes Tavern PHONE 314-323-7176
ADDRESS 901 N. Lafayette, Florissant, MO 63031
BUSINESS HOURS 8am - 1:30am
OWNER/MANAGER Mark Goldstein PHONE 314-323-7176
HOME ADDRESS 540 Rue St. Antoine, Florissant, MO 63031

PLEASE LIST PERSONS TO BE CONTACTED AFTER BUSINESS HOURS IN CASE OF AN EMERGENCY OR IF THERE IS A DOOR OR WINDOW FOUND INSECURE.

CONTACT #1 HAS KEY YES NO
NAME Mark Goldstein ADDRESS 540 Rue St. Antoine, Florissant, MO 63031
CITY & STATE Florissant, MO 63031 PHONE 314-323-7176

CONTACT #2 HAS KEY YES NO
NAME Joe Meyer ADDRESS 9015 Ave St. Joseph
CITY & STATE Florissant Mo. 63031 PHONE 314-495-5725

ARE THERE LIGHTS LEFT ON AFTER HOURS? YES NO
IS ANYONE AUTHORIZED TO BE ON THE PREMISES AFTER BUSINESS HOURS? YES NO

IF YES, WHO? _____
ARE ANY VEHICLES PARKED AT YOUR BUSINESS AFTER HOURS? YES NO

DESCRIBE: _____
(YEAR) (MAKE/MODEL) (COLOR) (LICENSE NO.)

DO YOU HAVE A SAFE OF ANY KIND? YES NO

WHERE IS IT LOCATED? _____

CAN IT BE SEEN FROM THE OUTSIDE? YES NO

IS YOUR BUSINESS PROTECTED WITH AN ALARM SYSTEM? YES NO

IF AT ANY TIME THERE IS A CHANGE IN THE ABOVE INFORMATION, PLEASE NOTIFY THE POLICE DEPARTMENT IMMEDIATELY, ESPECIALLY IN THE CASE OF THOSE PERSONS TO NOTIFY IN CASE OF AN EMERGENCY. THANK YOU.

CITY OF FLORISSANT



FLORISSANT, MISSOURI

WAIVER

Authorization to complete record check

I, Mark Goldstein, RESIDING AT

540 Rue St. Antoine IN THE

CITY OF Florissant, MO 63031 STATE OF
Missouri

I do hereby authorize the City Clerk of the City of Florissant, Missouri to make a full and complete check of my record in the Metropolitan St. Louis area, state of Missouri, all prior areas of residence, and through the National Criminal Information Center in Washington, D.C.

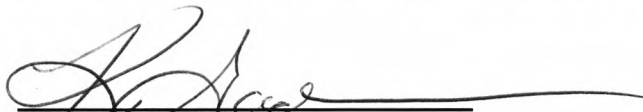

Witness



Signature

11/30/21

Date

05/13/1967

Date of Birth



Social Security Number**



Driver's License No. & State

**Social Security Number and Driver's License Numbers will be used for the purpose of identification in completing record check.

APPLICATION FOR SUNDAY LIQUOR LICENSE
TO THE CITY CLERK, CITY OF FLORISSANT, SAINT LOUIS COUNTY, MISSOURI

Authorizing the sale of retail liquor by the drink or package in the City of Florissant on **SUNDAY** from 9:00 am to midnight.

TYPE OF OPERATION:

Individual Partnership Corporation Limited Liability Corp

NAME OF BUSINESS Henkes Tavern

LOCATION 901 N. Lafayette, Florissant, MO 63031 **PHONE** 314-323-7176

EXACT TRADE NAME, LLC, OR CORP FloMO LLC

The undersigned (Individual, Partnership, Corporation, LLC), hereby makes application to the City Clerk, City of Florissant, St. Louis County, Missouri for a "By the Drink/Package Liquor License" authorizing the sale of retail liquor on Sundays from 9:00 am to midnight for the period beginning on 12/15/2021 and expiring on June 30, 2060, on the above described premises and agrees that if the license herein applied for is granted, and the licensee shall violate any provisions of the State Liquor Control Act or of the City of Florissant Code and particularly any provision of Chapter 600 of the Florissant City Code pertaining to alcoholic beverages or permit any other person to do so upon the licensed premises, the City Council, by a majority vote, may suspend or revoke such license.

1. I/WE presently hold Florissant License Number _____ authorizing the sale of retail liquor by the drink or package in Florissant for premises described in this application.

STATE OF MISSOURI)SS
COUNTY OF ST. LOUIS)

I Mark Goldstein of lawful age, being first duly sworn upon my oath, depose and say that I (Print name of Managing Officer) have read this application and that I fully understand the same; that I know the contents thereof and the statements contained therein and that the same are true of my own knowledge.

Mark Goldstein
Signature of Individual or Managing Officer

Subscribed and sworn to before me this 30 day of Nov. 2021.

My Commission Expires: 01-02-2022

Savanna B Burton
Notary Public

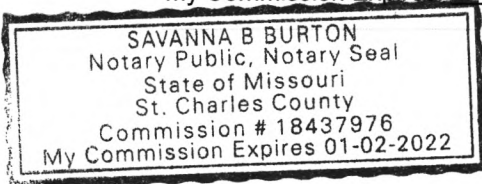



No Match Notification

A statewide search of the identifiers below has revealed no criminal conviction or sex offender information on file. Fingerprints were not provided and thus the result of the search cannot be guaranteed.

Date of Search: 11/30/2021

Name (1): MARK GOLDSTEIN

Name (2):

Name (3):

Date Of Birth: 05/13/1967

SSN: xxx-xx-1888

Control Number: 5774271

If you have any questions, please do not hesitate to contact our office at 573-526-6153.

Missouri State Highway Patrol
Criminal Justice Information Services Division
PO BOX 9500
Jefferson City, MO 65102

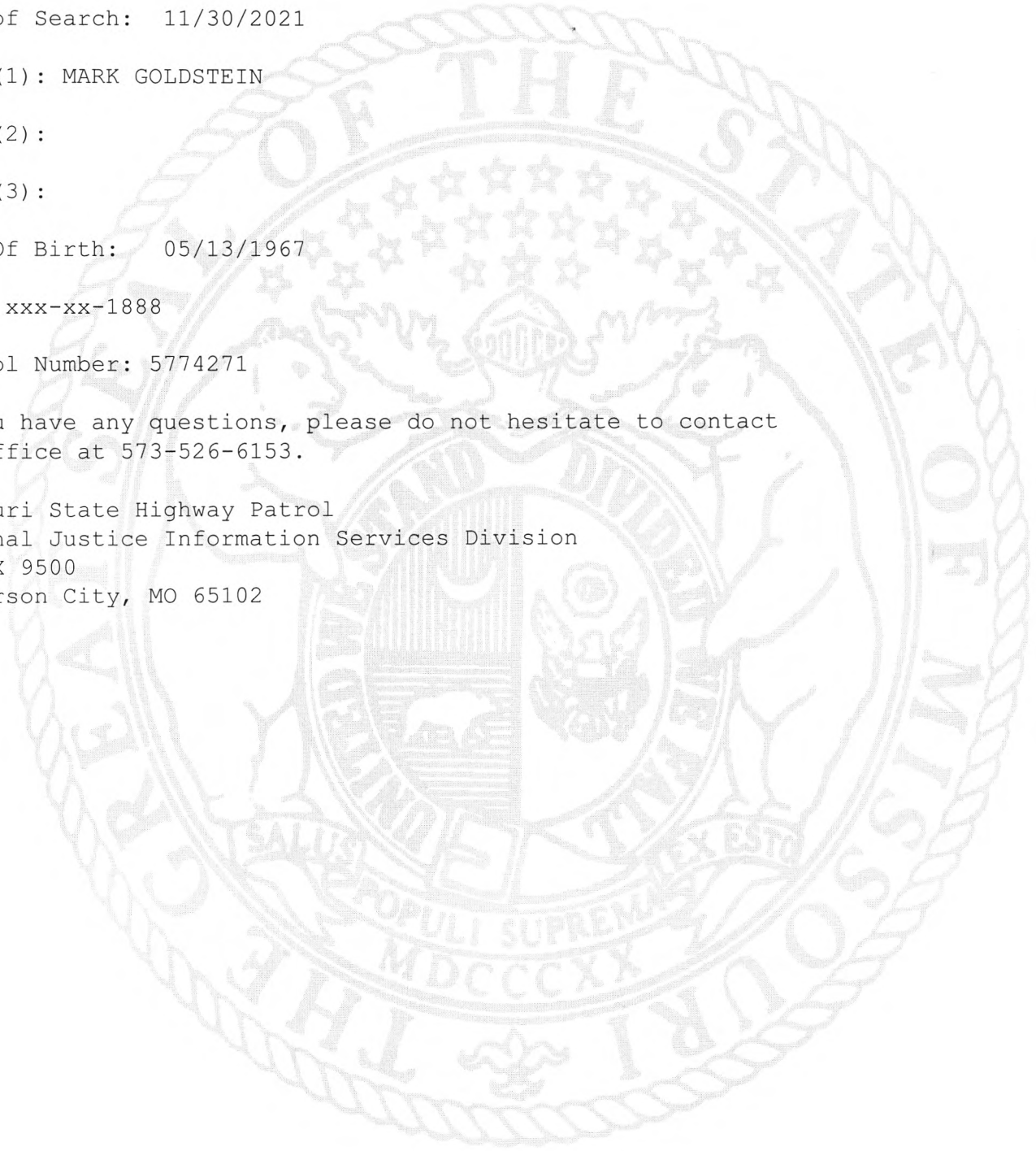

1 INTRODUCED BY COUNCILMAN MULCAHY
2 DECEMBER 13, 2021

3
4 BILL NO. 9745

ORDINANCE NO.

5

6 **ORDINANCE AUTHORIZING TRANSFER OF AN EXISTING NON-**
7 **CONFORMING SPECIAL USE FROM HENKE’S TAVERN TO FLOMO**
8 **LLC D/B/A HENKE’S TAVERN FOR THE OPERATION OF A**
9 **RESTAURANT-BAR LOCATED AT 901 N. LAFAYETTE.**

10

11

12 WHEREAS, the Florissant Zoning Ordinance authorizes the Council of the City of
13 Florissant, by Special Use Permit, after public hearing thereon, to permit the location of a
14 restaurant-bar; and

15 WHEREAS Henke’s Tavern has been operating at this location since 1974 before Special
16 Use Permits were required; and

17 WHEREAS Flomo LLC has filed an application to transfer the existing non-conforming
18 use of a restaurant-bar located at 901 N. Lafayette to its name; and

19 WHEREAS, the City Council of the City of Florissant determined at its meeting on
20 December 13th, 2021 that the business would be operated in substantially identical fashion as set
21 out herein; and

22 WHEREAS, Flomo, LLC has accepted the terms and conditions as they apply to a special
23 use permit for a restaurant-bar.

24

25 **NOW, THEREFORE, BE IT ORDAINED BY THE COUNCIL OF THE CITY OF**
26 **FLORISSANT, ST. LOUIS COUNTY, MISSOURI, AS FOLLOWS:**

27 Section 1: The existing non-conforming Special Use is hereby transferred from Henke’s
28 Tavern to Flomo LLC d/b/a Henke’s Tavern for the operation of a restaurant-bar located at 901
29 N. Lafayette.

30 Section 2: The Special Use Permit herein authorized shall terminate if the said business
31 ceases operation for a period of more than ninety (90) days.

32 Section 3: This ordinance shall become in force and effect immediately upon its passage
33 and approval.

34

35 .

36 Adopted this _____ day of _____, 2021.

37 _____

38 Keith Schildroth

39 Council President

40

41 Approved this _____ day of _____, 2021.

42 _____

43 Timothy J. Lowery

44 Mayor, City of Florissant

45

46

47 ATTEST:

48

49 _____

50 Karen Goodwin, MPPA/MMC/MRCC

51 City Clerk

TRANSFER OF SPECIAL PERMIT

AUTHORIZED BY ORDINANCE NUMBER (S) Existing - Non-Conforming

FROM Henkes LLC DBA Henkes Tavern

TO FloMo LLC DBA Henkes Tavern

FOR ADDRESS 901 N. Lafayette

Ward 6 Zoning B1 Date Filed 12/2/21 Accepted By [Signature]

TRANSFER OF SPECIAL USE PERMIT.PETITION

TO THE CITY COUNCIL OF THE CITY OF FLORISSANT:

1. Comes now Mark Goldstein - Managing Partner and states to the City Council that he (she) (they) has (have) the following legal interest in the property located at 901 N. Lafayette, Florissant, MO 63031 in the City of Florissant, Missouri. Legal interest: Lease or Simple Title (Attach signed copy of lease or deed)

2. The petitioner(s) further state that he (she) (they) has (have) not made any arrangement to pay any commission, gratuity, or consideration, directly or indirectly to any official, employee, or appointee of the City of Florissant, with respect to this petition.

3. The applicant will operate the business in the same manner and under the same conditions as set out in the original ordinance granting the special permit or any amendments thereto, except for any proposed change in sign face of an authorized sign.

PETITIONER SIGNATURE Mark Goldstein - Managing Partner
Individual's Name

FOR: FloMo LLC
Company, Corporation, Partnership

4. I (we) hereby certify that (indicate **one only**):

- I (we) have a legal interest in the above described property.
 I am (we are) the duly appointed agent (s) of the petitioner, and that all information given is true and a statement of fact.

SIGNATURE

Mark Goldstein - Fle Mo LLC Managing Partner

ADDRESS

540 Rue St. Antoine, Florissant, MO 63031

Telephone No.

314-323-7176

Email address

mgoldstein@goldmarkent.com

I (we) the petitioner(s) do hereby appoint Mark Goldstein as my (our) duly authorized agent to represent me (us) in regard to this petition.

Mark Goldstein

PETITIONER SIGNATURE

Note: Petitioner or his/her authorized agent will be the only person(s) permitted to make the presentation to the City Council.

5. Acknowledgement and consent of (**current**) owner to Transfer the Special Use Permit.

Joseph E Henke

SIGNATURE OF OWNER

Information sheet to be attached to all requests for Transfer of Special Permit

Type of Operation: (Select One)

Individual Partnership Corporation LLC

INDIVIDUAL:

Name & address _____

Telephone number & email address _____

Business name/address/phone _____

Copy of fictitious name registration, if applicable _____

PARTNERSHIP:

Name & address of partner (s) ⁹⁸³ Gary Meyer ⁹⁸⁵ Rue St. Antoine, Joe Meyer Rue St. Jacques, 63031, ₉₄₀ Scott Goldstein - N. Lafayette, 63031, Mark Goldstein - 540 Rue St. Antoine, 63031

Telephone number(s) and email address (s) 314-323-7176

Business name/ address /phone **FLOMO LLC dba Henkes Tavern**

Copy of fictitious name registration, if applicable

CORPORATION OR LLC:

Name & address of all corporate officers **FLOMO LLC**

Scott Goldstein - N. Lafayette, 63031, Mark Goldstein - 540 Rue St. Antoine, 63031, Gary Meyer - Rue St. Antoine, Joe Meyer - Rue St. Jacques, 63031

Telephone numbers & email addresses 314-323-7176

Business name/address/phone **FLOMO LLC, 901 N. Lafayette, 63031**

Photocopy of Corporation/LLC Articles and Certificate

Date of incorporation/LLC **November 2021**

Copy of fictitious name registration, if applicable

Copy of latest Missouri Anti-Trust affidavit (annual registration of corporate officers)

TRANSFER OF SPECIAL USE PERMIT

The undersigned hereby acknowledges receipt of a copy of Ordinance
Number Existing Non-Conforming Use which previously authorized a Special Use Permit:

TO: FloMo LLC DBA Hunkes Tavern

FOR: Restaurant & Bar

Located at: 901 N. Lafayette, Florence No. 63031

and agree to the terms and conditions listed in said ordinance and to any
additional term and conditions that the City Council shall deem appropriate.

Mark Goldstein - Managing Partner

PRINT - NAME OF APPLICANT

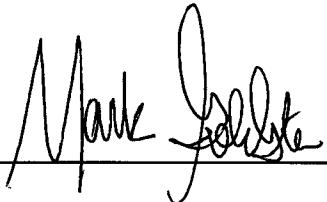

SIGNATURE OF APPLICANT



State of Missouri
John R. Ashcroft, Secretary of State
 Corporations Division
 PO Box 778 / 600 W. Main St., Rm. 322
 Jefferson City, MO 65102

LC014333191
Date Filed: 11/4/2021
John R. Ashcroft
Missouri Secretary of State

Articles of Organization

(Submit with filing fee of \$105.00)

1. The name of the limited liability company is
FloMo, LLC

(Must include "Limited Liability Company," "Limited Company," "LC," "L.C.," "L.L.C.," or "LLC")

2. The purpose(s) for which the limited liability company is organized:

The purpose for which the Company is organized is to acquire real estate and other investments. The Company may engage in any other activities related to or incidental thereto.

3. The name and address of the limited liability company's registered agent in Missouri is:

<u>Jonathan E. Fortman</u>	<u>250 St. Catherine Street</u>	<u>Florissant, MO 63031</u>
<i>Name</i>	<i>Street Address: May not use PO Box unless street address also provided</i>	<i>City/State/Zip</i>

4. The management of the limited liability company is vested in: managers members *(check one)*

5. The events, if any, on which the limited liability company is to dissolve or the number of years the limited liability company is to continue, which may be any number or perpetual: Perpetual

(The answer to this question could cause possible tax consequences, you may wish to consult with your attorney or accountant)

6. The name(s) and street address(es) of each organizer *(PO box may only be used in addition to a physical street address):*

(Organizer(s) are not required to be member(s), manager(s) or owner(s))

<i>Name</i>	<i>Address</i>	<i>City/State/Zip</i>
<u>Fortman, Jonathan E</u>	<u>250 Saint Catherine St</u>	<u>Florissant MO 63031-5006</u>

7. Series LLC (OPTIONAL) Pursuant to Section 347.186, the limited liability company may establish a designated series in its operating agreement. The names of the series must include the full name of the limited liability company and are the following:

New Series:

The limited liability company gives notice that the series has limited liability.

New Series:

The limited liability company gives notice that the series has limited liability.

New Series:

The limited liability company gives notice that the series has limited liability.

(Each separate series must also file an Attachment Form LLC 1A.)

Name and address to return filed document:
Name: <u>Jonathan Fortman</u>
Address: <u>Email: jef@fortmanlaw.com</u>
City, State, and Zip Code: _____

8. Principal Office Address (OPTIONAL) of the limited liability company (PO Box may only be used in addition to a physical street address):

250 Saint Catherine St

Florissant, MO 63031-5006

Address (PO Box may only be used in conjunction with a physical street address)

City/State/Zip

9. The effective date of this document is the date it is filed by the Secretary of State of Missouri unless a future date is otherwise indicated: _____

(Date may not be more than 90 days after the filing date in this office)

In Affirmation thereof, the facts stated above are true and correct:

(The undersigned understands that false statements made in this filing are subject to the penalties provided under Section 575.040, RSMo)

All organizers must sign:

Jonathan E Fortman

JONATHAN E FORTMAN

11/04/2021

Organizer Signature

Printed Name

Date of Signature

STATE OF MISSOURI



John R. Ashcroft
Secretary of State

CERTIFICATE OF ORGANIZATION

WHEREAS,

FloMo, LLC
LC014333191

filed its Articles of Organization with this office on the 4th day of November, 2021, and that filing was found to conform to the Missouri Limited Liability Company Act.

NOW, THEREFORE, I, John R. Ashcroft, Secretary of State of the State of Missouri, do by virtue of the authority vested in me by law, do certify and declare that on the 4th day of November, 2021, the above entity is a Limited Liability Company, organized in this state and entitled to any rights granted to Limited Liability Companies.

IN TESTIMONY WHEREOF, I hereunto set my hand and cause to be affixed the GREAT SEAL of the State of Missouri.
Done at the City of Jefferson, this 4th day of November, 2021.

Secretary of State

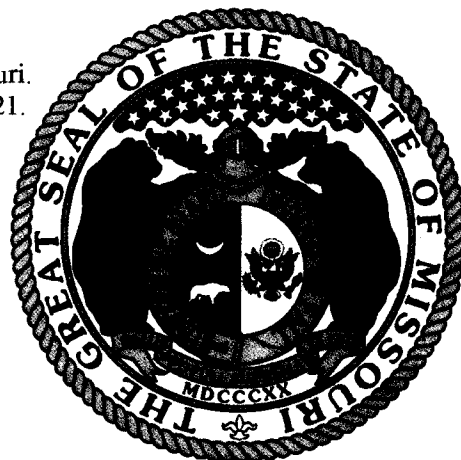

1 INTRODUCED BY COUNCILMAN SCHILDROTH
2 DECEMBER 13, 2021

3
4 BILL NO. 9746 ORDINANCE NO.

5
6 **ORDINANCE AMENDING ORDINANCE NUMBER 8008**
7 **ESTABLISHING THE PROPERTY ACQUISITION PROGRAM BY**
8 **UPDATING CERTAIN SECTIONS.**

9
10 WHEREAS, the Mayor and City Council of the City of Florissant believe
11 strongly in promoting the general welfare of the community; and

12 WHEREAS, the Mayor and City Council believe it is the best interest of the city
13 to amend the Property Acquisition Program to allow for updates.

14
15 BE IT ORDAINED BY THE COUNCIL OF THE CITY OF FLORISSANT, ST. LOUIS
16 COUNTY, MISSOURI, AS FOLLOWS:
17

18 Section 1: Ordinance no. 8008 is hereby amended by deleting the program
19 guidelines in their entirety and replacing them with a new set of guidelines as attached
20 hereto.

21
22 Section 2: This ordinance shall become in force and effect immediately upon its passage
23 and approval.

24
25 Adopted this _____ day of _____, 2021.

26
27
28 _____
29 Keith Schildroth
30 President of the Council
31 City of Florissant

32 Approved this _____ day of _____, 2021.

33
34
35 _____
36 Timothy J. Lowery
37 Mayor, City of Florissant

38 ATTEST:
39
40 _____
41 Karen Goodwin, MPPA/MMC/MRCC
City Clerk

FLORISSANT
PROPERTY ACQUISITION PROGRAM (PAP)
GUIDELINES

1. **NAME** - The Florissant Property Acquisition Program (PAP).

PURPOSE - In accordance with an Ordinance adopted by the Florissant City Council, a Property Acquisition Program is herein created for the benefit of the citizens of the City of Florissant, Missouri. The City of Florissant Missouri is committed to homeownership and neighborhood preservation and revitalization which protects our property values and is important to all residents, homeowners and businesses, as well as School Districts, organizations and the region as a whole. The purpose of the program is to establish a Homeownership and Revitalization Program in an effort to promote the general welfare of the community.

The City of Florissant, in order to promote area revitalization, is adopting a program that would allow the City to acquire properties in the City limit that are delinquent in taxes, abandoned, blighted, foreclosed etc. Once these properties have been acquired the City would stabilize them and find buyers that will bring the properties up to code and occupancy standards.

Funding for this program is from the Property Revitalization Fund of the City of Florissant. This program will provide greater community stability and will strengthen the tax base of the community by preserving and improving single-family home values, but is limited to the allocated, dedicated funds in the amount set forth above.

2. **ADMINISTRATION** - The program will be administered by the Community Development Director, with oversight by the Mayor. The role of the Community Development Director will be to administer the Homeownership Assistance Program. The specific duties and functions of the Community Development Director in policy and administration shall include the following:
- A. Conduct the day-to-day operations of the program.
 - B. Establish policies and procedures of the program and recommend substantive changes to the Mayor.
 - C. Select and enter into contractual agreements necessary to administer the program subject to the approval of the Mayor.
3. **PROCEDURES FOR OBTAINING PROPERTY** - The St Louis County Department of Revenue publish lists of property with 3 (or more) years of

delinquent taxes, and then offer them for sale. After they have been published and offered for sale 3 times, they may be conveyed to a taxing authority for little or no cost.

In accordance with their guidelines, the City of Florissant can request that these properties be given to the City.

- A. The City must pass an ordinance stating our request to acquire the property, and send written request to the St Louis County Collector of Revenue.
- B. The city runs a title search and notifies all parties of record of intent to take the property for taxes. The city then signs an affidavit stating that these notifications took place more than 90 days ago, and if nobody comes forward to "redeem" the property, a Collectors Deed will be issued to the City of Florissant
- C. Should the property be redeemed, the City of Florissant files a claim for all amounts spent for title search and notification and will be reimbursed for these costs per MO State Statute.

4. **PROCEDURES FOR STABILIZING PROPERTY** - Once the deed is issued and recorded the City will stabilize the property:

- A. The City starts a Quiet Title action with the Circuit Court of St Louis County.
- B. If the property is vacant, get a locksmith and change the locks to make sure the building is secure.
- C. Do a complete inspection of the property (interior and exterior) to determine the condition of the property.
- D. Insure the property and install alarms.
- E. Stabilize the property by performing any exterior maintenance required for health and safety reasons, such as board up, fixing leaks, cleaning gutters, grounds, weed and grass, and any structural property issues etc.

5. **PROCEDURES FOR DISPOSITION OF PROPERTY** - Once the city receives a clear title through the Circuit Court, the goal will be to find a buyer that will bring the property up to code and occupancy standards and will dispose of the parcels in the City's best interest.

~~A. The city will advertise the home for sale by sealed bids with the minimum bid requirement.~~

~~—The city will have an open house for prospective buyers to view property, and will make copies of the inspection report available.~~

~~B. Sealed bids will be submitted along with certified funds in the amount of \$1,000 with each bid. (non refundable if bidder fails to complete purchase)~~

~~B. Bid opening date will be posted—high bidder will be awarded the property~~

~~All sales are final, and this will be an "as is" sale, with the following stipulations:~~

~~—High bidder must submit certified funds for the full amount of the high bid within 2 business days of bid opening. Once this is done, the city will prepare a deed and record with the Recorder of Deeds of St Louis County.~~

~~—The buyer will have 90 days from the date of closing to bring the property up to code and pass an occupancy permit inspection. An extension may be granted by the city (Director of Public works, or his designee) if buyer can show that progress is being made to make needed repairs.~~

~~—There will be a lien placed on the property at the time of closing for an amount equal to the bid amount paid by the buyer. This lien will be forgiven and released once the property is inspected and passes an occupancy inspection.~~

~~—Should the buyer not comply with the terms of the sale, the lien will be called and paid in full within 30 days, or the property forfeited to the City of Florissant.~~

~~—All proceeds from the sale will be returned to the Florissant Revitalization Fund for future use.~~

6. **GUARANTEE FUND** - For the purposes of paying the costs of administering the program and extending protection to members pursuant to the limitations and procedures set forth in this ordinance, a guarantee fund shall be created as defined herein (The Property Revitalization Fund). Payments made for administration costs, purchase and stabilization of properties against the guarantee fund shall be absolutely limited to an amount not to exceed the amount actually on hand at the time of said loans. All proceeds from sale or non-compliance will be returned to the General Fund. ~~Property Revitalization Fund.~~

An independent audit of the guarantee fund and the management of the program shall be conducted annually in conjunction with the city's annual financial audit, and made available to the public at the Community Development office.

7. **OTHER CONDITIONS** – Participants shall agree to abide by all conditions, stipulations, and provisions of this ordinance and program as contained herein and as amended in the future, and shall not be eligible for participation unless all such conditions, stipulations and provisions have been met.
8. **EXCLUSIONS** - The following items shall be excluded under the program:
 - A. Any person who knowingly affirms falsely any matter or thing required to be affirmed by the terms of the program is guilty of perjury.
 - B. Any fraud, misrepresentation or concealment on the part of a participant in any process involving this ordinance or the City of Florissant shall negate all coverage provided that member by this ordinance.
9. **RIGHT TO REVIEW, REVISE AND SUSPEND PROGRAM**

City of Florissant reserves the right to review, revise or discontinue the program at any time.
10. **SUITS** -
 - A. No lawsuit or any other type of legal action brought under this program shall be sustainable in a court of law or equity unless all conditions, stipulations and provisions of the program have been complied with, and unless the suit is brought within twelve (12) months after the event which is the subject of the legal action.
 - B. No employee of the City of Florissant, whether on salary, wages or voluntary basis shall be personally liable and no cause of action may be brought for damages resulting from the exercise of judgment or discretion in connection with the performance of program duties or responsibilities unless the act or omission involved willful or wanton misconduct, intentional misconduct, knowing violation of the law or for any such transaction from which said individual derives an improper personal benefit.
11. **NON-DISCRIMINATION POLICY** - No provision of the policies and procedures of the program are intended as and none shall be used as a means of discriminating against any individual on the basis of familial status, ethnic background, gender, race, religion or disability.
12. **AMENDMENTS** - The policies, procedures, rules and regulations of this program shall be reviewed by the Community Development Director and the Mayor on an annual basis. Proposed amendments to this ordinance will be presented to the City Council, who may adopt said amendment.

13. **RIGHT TO WITHDRAW** - None of the provisions of this ordinance or any amendments thereto shall abridge a member's right to forfeit the registration fee and withdraw from the program at any time and sell the insured residence in any legal manner he or she sees fit.

FLORISSANT CITY COUNCIL

AGENDA REQUEST FORM

Date: December 6, 2021

Mayor's Approval

Agenda Date Requested:

13-Dec-21



Description of request: Property Acquisition
Program Changes

Department: Community Development

Recommending Board or Commission:

Type of request:

Ordinances	X	Other	X
Appropriation		Liquor License	
Transfer		Hotel License	
Zoning Amendment		Special Presentations	
Amendment	X	Resolution	
Special Use Transfer		Proclamation	
Special Use		Subdivision	
Budget Amendment			
	Y/N		Y/N

Public Hearing needed: Yes / No

NO

3 readings? : Yes / No

Y/N

Back up materials attached:

Back up materials needed:

Minutes		Minutes	
Maps		Maps	
Memo	YES	Memo	
Draft Ord.		Draft Ord.	

Note: Please include all attachments necessary for documents to be generated for inclusion on the Agenda. All agenda requests are to be turned in to the City Clerk by 5pm on Tuesday prior to the Council meeting.

For City Clerk Use Only:

Introduced by: _____

PH Speaker: _____

MEMORANDUM

To: MAYOR LOWERY & FLORISSANT CITY COUNCIL
From: M. Carol O'Mara, Director Community Development
Re: Property Acquisition Program Changes
Date: December 6, 2021

After a recent review of the Property Acquisition Program (PAP) it was determined that an amendment to the Property Acquisition Program guidelines ordinance #8008, would be prudent for the close out of the program.

I am recommending amending ordinance # 8008 to update the program in regards to the disposition of properties by deleting paragraph #5 and replacing it in its entirety with "DISPOSITION OF PROPERTY - Once the city receives a clear title through the Circuit Court, the goal will be to find a buyer that will bring the property up to code and occupancy standards and will dispose of the parcels in the City's best interests as determined by the Mayor with guidance from staff." The other change is the last sentence in paragraph #6 to read "All proceeds from sale or non-compliance will be returned to the General Fund."

These proposed changes enable us to simplify and make the process easier to have the flexibility to close the program out.

1 INTRODUCED BY COUNCIL AS A WHOLE
2 OCTOBER 28, 2013

3
4 BILL NO. 8957

ORDINANCE NO. 8000

5
6 **AN ORDINANCE CREATING AND ESTABLISHING A FLORISSANT**
7 **“PROPERTY AQUISITION PROGRAM”.**
8

9 WHEREAS, the Mayor and City Council of the City of Florissant believe
10 strongly in promoting the general welfare of the community; and

11 WHEREAS, the Mayor and City Council believe it is the best interest of the city
12 to create a Property Acquisition Program which will allow the city to accept assignment
13 of certain properties within the city limits that are delinquent in real estate property
14 taxes and have been offered for sale by the S.t Louis County Collector of Revenue at
15 least three (3) times and the property has not been sold so that the city can find buyers
16 that will bring the properties up to code and occupancy standards.

17
18 BE IT ORDAINED BY THE COUNCIL OF THE CITY OF FLORISSANT, ST. LOUIS
19 COUNTY, MISSOURI, AS FOLLOWS:
20

21 Section 1: There is hereby created and established a Florissant “Property
22 Acquisition Program” in accordance with the Regulations, a copy of which is attached
23 hereto and incorporated by reference herein.
24

25 Section 2: This ordinance shall become in force and effect immediately upon its passage
26 and approval.

27
28 Adopted this 11 day of NOV, 2013.

29
30 
31 Keith Schildroth
32 President of the Council
33 City of Florissant
34

35 Approved this 12 day of NOV, 2013.

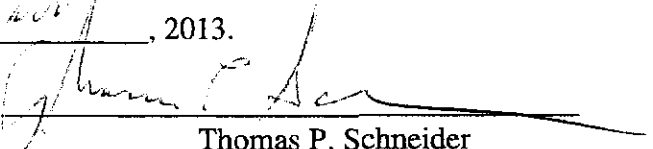
36
37 
38 Thomas P. Schneider
39 Mayor, City of Florissant

40 ATTEST:

41 
42
43 Karen Goodwin, MMC/MRCC
44 City Clerk

8 0 0 8

FLORISSANT
PROPERTY ACQUISITION PROGRAM
REGULATIONS

1. **NAME** - The Florissant Property Acquisition Program (the "PAP").
2. **PURPOSE** - In accordance with an Ordinance adopted by the Florissant City Council, a Property Acquisition Program ("PAP") is created for the benefit of the citizens of the City of Florissant, Missouri. The City of Florissant Missouri is committed to homeownership and property revitalization in order to promote the general welfare of the community. The City of Florissant, in order to promote area revitalization, is adopting the PAP to allow the City to accept the assignment of certain properties in the city limits that are delinquent in real estate property taxes and have been offered for sale by the St. Louis County Collector of Revenues at least three (3) times and the property has not been sold. The City will accept ownership assignment of the property and comply with the requirements set forth in § 140.405, R.S.Mo. Once these properties have been assigned to the City, the City would stabilize them and find buyers that will bring the properties up to code compliance and occupancy standards.

Funding for the PAP is from the Property Revitalization Fund (the "Fund") of the City of Florissant. The PAP will provide greater community stability and will strengthen the tax base of the community by preserving and improving single-family home values. The funding for PAP is limited to the amount of money in the Fund and those amounts allocated to the PAP.

3. **ADMINISTRATION** - The PAP will be administered by the Community Development Director, with oversight by the Mayor. The role of the Community Development Director will be to administer the PAP. The specific duties and functions of the Community Development Director in policy and administration shall include the following:
 - A. Conduct the day-to-day operations of the PAP.
 - B. Establish policies and procedures of the PAP and recommend substantive changes to the Mayor.
 - C. Select and enter into contractual agreements necessary to administer the PAP subject to the approval of the Mayor.
4. **PROCEDURES FOR OBTAINING PROPERTY** - The St Louis County Department of Revenue publishes lists of properties with 3 (or more) years of delinquent taxes, and then offers them for sale. After they have been published and offered for sale 3 times, they may be conveyed to a taxing authority.

In accordance with applicable state law and the guidelines of St. Louis County, the City of Florissant can request that these properties be assigned to the City as follows:

- A. The City will pass an ordinance authorizing the acceptance of ownership and assignment of the real property held by the St Louis County Collector of Revenue;
 - B. The city will run a title search and notify all parties of record of intent to take the property for taxes.
 - C. The city will sign an affidavit stating that these notifications took place more than 90 days prior to transfer, and if nobody comes forward to "redeem" the property, a Collector's Deed will be issued to the City of Florissant
 - D. If the property is redeemed, the City of Florissant will file a claim for all amounts spent for title search, and notification and will be reimbursed for these costs per Missouri State Statute.
5. **PROCEDURES FOR STABILIZING PROPERTY** - Once a Collector's Deed is issued and recorded, the City will undertake steps to stabilize the property, including the following:
- A. The City may file a Quiet Title action in the Circuit Court of St Louis County.
 - B. If the building(s) on the property are vacant, the City may get a locksmith and change the locks to make sure the building(s) are secure.
 - C. The City will do a complete inspection of the building(s) (interior and exterior) to determine the condition of the property.
 - D. The City will insure the property and install alarms.
 - E. The City will stabilize the building(s) by performing any exterior maintenance required for health and safety reasons, such as board up, fixing leaks, cleaning gutters, grounds, weed and grass, and any structural issues etc.
6. **PROCEDURES FOR DISPOSITION OF PROPERTY** - Once the city receives clear title to the property, the goal will be to find a buyer that will bring the

property into compliance with all ordinances, including building code and occupancy standards.

- A. The city will take reasonable steps to offer the property for sale (which may include posting the property, advertisement and notification to developers) in which sealed bids will be submitted to the City with a minimum bid requirement.
 - B. The city may have an open house for prospective buyers to view the property, and will make copies of any available inspection reports.
 - C. Sealed bids will be submitted along with certified funds in the amount of \$1,000 with each bid (non refundable if bidder fails to complete purchase).
 - D. Bid opening date will be posted, and the highest, most responsible bid will be awarded the property subject to the negotiation of conditions and/or restrictions that will be included in the deed, including rights of reversion and re-entry in the event conditions are not satisfied.
 - E. All sales will be on an "as is" basis, and will be subject to the following stipulations:
 - 1. High bidder must submit certified funds for the full amount of the bid within 2 business days of bid opening. Once this is done, the city will prepare a deed subject to certain conditions and/or restrictions, including reversionary rights and rights of re-entry in the event that the conditions are not satisfied within the timeframe set forth therein.
 - 2. The deed with rights of reversion and re-entry will be recorded with the Recorder of Deeds of St. Louis County.
 - 3. In the event the buyer fails to satisfy all of the conditions and restrictions set forth in the deed, the city shall have the right to exercise its reversionary rights and rights of re-entry.
 - 4. In the event the buyer satisfies all of the conditions and restrictions in the deed, the city shall file the deed for the sole purpose of releasing reversionary and re-entry rights.
 - 5. All proceeds from the sale will be returned to the Florissant Revitalization Fund for future use.
7. **FUND** - For the purposes of paying the costs of administering the PAP, the Florissant City Council has established the Fund. Payments made for administration costs, purchase and stabilization of properties shall be limited to

an amount available in the Fund at the time. All proceeds from sale or non-compliance will be returned to the Fund.

An independent audit of the Fund shall be conducted in conjunction with the city's annual financial audit, and made available to the public at the Community Development office.

8. **OTHER CONDITIONS** – Participants shall agree to abide by all of the requirements of the PAP, as contained herein and as amended in the future, and shall not be eligible for participation unless all such conditions, stipulations and provisions have been met.
9. **EXCLUSIONS** - The following actions shall exclude persons from participating in the PAP:
 - A. Any person who knowingly affirms falsely any matter or thing required to be affirmed by the terms of the PAP is guilty of perjury, and shall be ineligible for participation in the PAP.
 - B. Any fraud, misrepresentation or concealment on the part of a participant in *any process involving this ordinance or the City of Florissant* shall result in making the person ineligible and shall cause a forfeiture of all benefits provided herein.
10. **RIGHT TO REVIEW, REVISE AND SUSPEND PROGRAM**

City of Florissant reserves the right to review, revise or discontinue the PAP at any time.
11. **REPRESENTATIONS AND WARRANTIES** -
 - A. It is agreed and understood by any participant in the PAP that they shall not be entitled to assert any claim or any type of legal action against the City of Florissant or its employees and elected officials arising out of or related to the PAP.
 - B. No employee or elected official of the City of Florissant shall be personally liable and no cause of action may be brought for damages resulting from the exercise of judgment or discretion in connection with the performance of the PAP.
12. **NON-DISCRIMINATION POLICY** - No provision of the regulations and procedures of the PAP are intended as, and none shall be used as, a means of discriminating against any individual on the basis of familial status, ethnic background, gender, race, religion or disability.

13. **AMENDMENTS** - The policies, procedures, rules and regulations of the PAP shall be reviewed by the Community Development Director and the Mayor, and any proposed amendments to these Regulations must be approved by the City Council.

1 INTRODUCTION BY COUNCIL AS A WHOLE
2 DECEMBER 13, 2021

3
4 BILL NO. 9748

ORDINANCE NO.

5
6 AN ORDINANCE CALLING AN ELECTION IN THE CITY OF
7 FLORISSANT, MISSOURI, ON THE QUESTION OF ISSUING
8 GENERAL OBLIGATION BONDS FOR THE PURPOSE OF
9 CONSTRUCTING AN AQUATIC CENTER.
10

11
12 WHEREAS, the City Council finds it necessary and hereby declares its intent to borrow
13 \$9,000,000 for the purpose of constructing an aquatic center (the "Project") and to evidence such borrowing
14 by the issuance of general obligation bonds of the City in the amount of \$9,000,000; and

15
16 NOW, THEREFORE, BE IT ORDAINED BY THE COUNCIL OF THE CITY OF
17 FLORISSANT, MISSOURI, AS FOLLOWS:

18
19 Section 1. An election is hereby ordered to be held in the City on April 5, 2022, on the following
20 proposition:

21
22 PROPOSITION A

23
24 Shall the City of Florissant, Missouri, issue its general obligation
25 bonds in an amount up to Nine Million Dollars (\$9,000,000) for the
26 purpose of constructing an aquatic center?
27

28 The authorization of the bonds (the "Bonds") will authorize the levy and collection of an annual
29 tax in addition to the other taxes provided for by law on all taxable tangible property in the City sufficient
30 to pay the interest and principal of the Bonds as they fall due and to retire the same within twenty years
31 from the date thereof.

32
33 Section 2. The form of the Notice of Bond Election for said election, a copy of which is attached
34 hereto as Exhibit A and made a part hereof, is hereby approved.

35
36 Section 3. The City Clerk is hereby authorized and directed to notify the Board of Election
37 Commissioners of St. Louis County, Missouri, of the adoption of this Ordinance no later than 5:00 p.m. on
38 January 25, 2022, and to include in said notification all of the terms and provisions required by Chapter 115
39 of the Revised Statutes of Missouri, as amended, and the City Charter.

40
41 Section 4. The City expects to make expenditures on and after the date of adoption of this
42 Ordinance in connection with the Project, and the City intends to reimburse itself for such expenditures
43 with the proceeds of the Bonds. The maximum principal amount of Bonds expected to be issued for the
44 Project is \$9,000,000.

45
46 Section 5. The City Council hereby authorizes and empowers the officers and representatives of
47 the City to take all such acts and to execute, acknowledge and deliver all such documents as may in their
48 discretion be determined to be necessary or desirable in order to carry out or comply with the terms and
49 provisions of this Ordinance, including but not limited to submittal of election documents as provided
50 herein with such final changes consistent herewith as may be necessary and proper, the conduct of such
51 election, the issuance of such Bonds upon voter approval, the related adjustment of tax rates, and the

52 payment of related expenses as provided herein. All of the acts and undertakings of such officers and
53 representatives which are in conformity with the intent and purpose of this Ordinance whether heretofore
54 or hereafter taken or done shall be and the same are hereby in all respects ratified, confirmed and approved.
55

56 **Section 6.** This Ordinance will take effect and be in full force from and after its passage by the
57 City Council and approval by the Mayor.
58

59
60 **PASSED AND APPROVED** by the City Council of the City of Florissant, Missouri, this _____
61 day of January, 2022.

62
63 Adopted this _____ day of January, 2022.
64

65
66
67
68 _____
69 **Keith Schildroth**
70 President of the Council

71
72 Approved this _____ day of January, 2022.
73

74
75
76
77 _____
78 **Timothy J. Lowery**
79 Mayor

80
81 (SEAL)

82
83
84 ATTEST:

85
86
87 _____
88 Karen Goodwin, MPPA, MMC, MRCC
89 City Clerk

90
91
92
93 First Reading: December 13, 2021

EXHIBIT A

**NOTICE OF BOND ELECTION
CITY OF FLORISSANT, MISSOURI**

Notice is hereby given to the qualified voters of the City of Florissant, Missouri (the “City”), that the City Council of the City has called an election to be held in the City on April 5, 2022, commencing at 6:00 a.m. and closing at 7:00 p.m., on the propositions contained in the following sample ballot:

**OFFICIAL BALLOT
CITY OF FLORISSANT, MISSOURI**

APRIL 5, 2022

PROPOSITION A

Shall the City of Florissant, Missouri, issue its general obligation bonds in an amount up to Nine Million Dollars (\$9,000,000) for the purpose of constructing an aquatic center?

YES
NO

INSTRUCTIONS TO VOTERS: If you are in favor of a proposition, place an X in the box opposite “YES.” If you are opposed to a proposition, place an X in the box opposite “NO.”

The authorization of said bonds will authorize the levy and collection of an annual tax in addition to the other taxes provided for by law on all taxable tangible property in the City sufficient to pay the interest and principal of said bonds as they fall due and to retire the same within twenty years from the date thereof.

The election will be held at the following polling places in the City:

PRECINCT	POLLING PLACE
_____	_____
_____	_____

DATED: _____, 2022.

Board of Election Commissioners
of St. Louis County, Missouri

Continuation of the Local Motor Vehicle Sales Tax - Talking Points

Background

- <City Name> residents used to pay city sales tax and Missouri highway use tax (equal to state sales tax) on vehicles bought out of state when we licensed them. All tax was paid in Missouri, not in the state where the vehicle was purchased.
- A 2012 change in the interpretation of the law changed everything. Under the ruling when a <City Name> resident licenses a car purchased out of state or from an individual, they did not pay city sales tax. (They don't pay sales tax in the state where they made the purchase, either.)
- In 2013, the Missouri Legislature provided municipalities with temporary relief from this tax loophole. Local sales tax on such sales would be collected, but cities must receive voter approval to keep the loophole closed by November of 2016.
- If the loophole isn't closed a <City Name> resident who purchases a vehicle from a Missouri car dealer, they must still pay local sales tax. This means that with tax, the same car sold at the same price will cost more if purchased locally than if it is purchased from out-of-state dealers. This puts local dealers at a disadvantage, encouraging <City Name> residents to do business outside of Missouri.
- <City Name> needs these tax dollars for basic services like street and sewer maintenance and police and fire protection.
- This is not a "double tax". The Local Use Tax applies only on transactions where no sales tax was already applied. If you paid tax when you made the purchase, you don't pay it a second time.

The Ballot measure:

- <City Name>'s Measure to Discontinue the Local Sales Tax on Vehicle Purchases issue will be on the (Date) ballot.

Why is the Continuation of the Local Sales Tax on Out-Of-State Vehicle Purchases so important to <City Name>?

- <City Name> has depended on this important revenue source in the past to fund ongoing city projects. The (\$ amount) in projected annual lost revenue could fund (# pothole replacements, # police officers, # firemen, etc).
- Today, <City Name> businesses are at a competitive disadvantage to out-of-state businesses, who don't charge sales tax on our vehicle purchases. These out-of state businesses don't create local jobs or reinvest in our community. It's not fair or wise that tax breaks encourage <City Name> residents to leave Missouri to make large purchases.



Benefits from the Local Use Tax

Why is a vote to discontinue the Local Sales Tax on Out-of-State Vehicles necessary?

A 2012 court ruling created a loophole allowing out-of-state vehicle sales to escape paying the local sales tax. The state sales tax is still imposed on these sales. In 2013 the Missouri Legislature re-imposed the local sales tax on out-of-state vehicle purchases with the caveat that citizen be provided the option to discontinue the tax by November 2016.

How much annual revenue does <City Name> expect to generate from the imposition of the local sales tax on out-of-state vehicle purchases?

(Fill in the blank)

What local services would be lost if the local sales tax on out-of-state vehicle sales is discontinued?

The Use Tax will go into <City Name>'s general revenue fund, providing funding resources for city services from street repair to police and fire protection. [insert appropriate info. i.e., "The expected revenues would be enough to repair 10,000 pot holes in our streets, fund the salaries of two additional policemen, or purchase a new fire truck."]

Will continuation of the Sales Tax on Out-Of-State vehicle purchases have other local benefits?

In addition to providing an important source of revenue for city services, continuation of the local Sales Tax on Out-Of-State Vehicle purchases is an important tool in leveling the playing field for local businesses. With no local use tax in place, local residents have an incentive to cross state lines to buy instead of buying locally. This costs us local jobs and sends [tens of thousands of] dollars out of our local economy.

Election information

What is the date of the election when the Discontinuation of the local Sales Tax on Out-Of-State Vehicles will be on the ballot?

The <City Name> Use Tax measure has been placed on the [date] ballot.

Can I vote absentee?

Yes. Absentee votes will be accepted until (_____). Contact (_____ at _____) to obtain an absentee ballot.

Other Questions/Speaker Requests

Who can I contact for more information about the local Sales Tax on Out-Of-State Vehicles?

If you have other questions about the local Use Tax or would like to arrange for a speaker to present information to your group, please contact [contact info].

1 INTRODUCED BY COUNCIL AS A WHOLE

3 BILL NO. 9747

ORDINANCE NO.

5 AN ORDINANCE OF THE CITY OF FLORISSANT, MISSOURI,
6 AUTHORIZING AND DIRECTING THE SUBMISSION OF A BALLOT
7 PROPOSITION TO THE QUALIFIED VOTERS OF THE CITY OF
8 FLORISSANT, MISSOURI, TO CONSIDER IMPOSING A LOCAL USE TAX AT
9 THE SAME RATE AS THE LOCAL SALES TAX OF THE CITY OF
10 FLORISSANT, MISSOURI, FOR PURCHASES FROM OUT-OF-STATE
11 VENDORS THAT EXCEED TWO THOUSAND DOLLARS.

14 WHEREAS, the City of Florissant, Missouri, believes a local use tax will help level the economic
15 playing field between local retail merchants and out-of-state vendors, and that the revenue from such a
16 tax will support the provision of critical municipal services and, therefore seeks to have the ballot
17 proposition hereinafter referenced presented to qualified voters of the City at an election to be held on
18 April 5, 2022.

20 NOW, THEREFORE BE IT ORDAINED BY THE CITY COUNCIL OF THE CITY OF
21 FLORISSANT, MISSOURI AS FOLLOWS:

23 **Section 1.**

25 Pursuant to the requirements of Article X, Section 22 of the Missouri Constitution and in
26 accordance with Section 144.757, RSMo., the following proposition shall be submitted to the qualified
27 voters of the City of Florissant at the election to be held on April 5, 2022, to wit:

29 **PROPOSITION U**

31 “Shall the City of FLORISSANT be authorized to impose a local use tax at the same rate as the
32 local sales tax by a vote of the governing body, provided that if any local sales tax is repealed,
33 reduced or raised by voter approval, the respective local use tax shall also be repealed, reduced or
34 raised by the same action? A use tax return shall not be required to be filed by persons whose
35 purchases from out-of-state vendors do not in total exceed two thousand dollars in any calendar
36 year”.

38 Yes No

40 **INSTRUCTIONS TO VOTERS:** If you are in favor of the Proposition, fill in the circle
41 opposite the word “Yes”. If you are opposed to the Proposition, fill in the circle opposite the
42 word “No”.

44 **Section 2.**

46 The City Clerk shall prepare and cause to be forwarded to the Board of Election Commissioners
47 of St. Louis County, Missouri, a Notice of Election in compliance with this ordinance and take such
48 other steps as may be required so that an election may be lawfully conducted.

49
50
51
52
53
54
55
56
57
58
59
60
61
62
63
64
65
66
67
68
69
70
71
72
73
74
75
76
77
78
79
80
81
82
83
84

Section 3.

The Board of Election Commissioners of St. Louis County shall conduct such election according to the law and certify the results thereof. Said Board of Election Commissioners shall designate such polling places as shall be required for said election and shall appoint such necessary election officials as may be required for the conduct thereof. Said Board of Election Commissioners shall also publish such notice of said election as shall be required by law and shall do and perform such other necessary acts as may be required to conduct such election in accord with the statutes of the State of Missouri and the ordinances of the City of Florissant, Missouri.

Section 3: This ordinance shall become in full force and effect immediately upon its passage and approval.

Adopted this _____ day of _____, 2021.

Keith Schildroth
President of the Council

Approved this _____ day of _____, 2021.

Timothy J. Lowery
Mayor, City of Florissant

ATTEST:

Karen Goodwin, MPPA/MMC/MRCC
City Clerk

FLORISSANT CITY COUNCIL

AGENDA REQUEST FORM

Date: December 8, 2021

Mayor's Approval:

Agenda Date Requested: 1

13-Dec-21

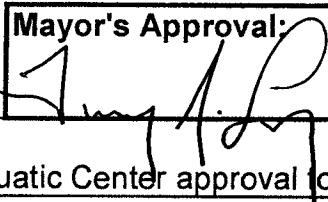

Approval of Prop A - General Obligation Bond for Aquatic Center approval to submit for the April 2022 Election to collect \$9 million dollars for construction of a new Aquatic Center in the City of Florissant.

Recommending Board or Commission:

Type of request:

Ordinances	X	Other	X
Appropriation		Liquor License	
Transfer		Hotel License	
Zoning Amendment		Special Presentations	
Amendment		Resolution	
Special Use Transfer		Proclamation	
Special Use		Subdivision	
Budget Amendment	X		

Public Hearing needed: **Yes / No**

NO

3 readings? : **Yes / No**

YES

Back up materials attached:

Back up materials needed:

Minutes

Minutes

Maps

Maps

Memo

Memo

Draft Ord.

Draft Ord.

Note: Please include all attachments necessary for documents to be generated for inclusion on the Agenda. All agenda requests are to be turned in to the City Clerk by 5pm on Tuesday prior to the Council meeting.

For City Clerk Use Only:

Introduced by: _____

PH Speaker: _____

**CITY OF FLORISSANT
PARKS AND RECREATION DEPARTMENT
Memorandum**

Date: December 7, 2021
To: City Council
Thru: Mayor Tim Lowery
From: Cheryl A. Thompson-Stimage
Subject: Prop A –General Obligation Bond for Aquatic Center

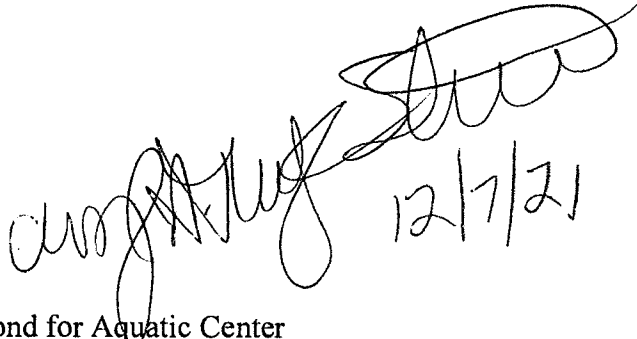
12/7/21

The attached ordinance is calling for an election in April for a General Obligation Bond for the purpose of constructing a new aquatic center. This Bond is asking for a total of \$9 million dollars. The bond issue will be called Prop A and would go on the ballot in April.

Thank you for your consideration on this matter.

A tract of land being part of Lots 110 and 112 of the New Town of St. Ferdinand, according to the plat thereof recorded in Plat Book 5 page 1 of the City of St. Louis (former County) Records, and in Township 47 North, Range 6 East, City of Florissant, Missouri, said tract being more particularly described as follows: Beginning at a point of intersection of the Southern line of St. Michael Street, 42.75 feet wide, with the Eastern line of a 20 foot wide strip described in deed to the City of Florissant, recorded in Book 1701 page 74 of the St. Louis County Records; thence South 58 degrees 43 minutes 20 seconds East 269.94 feet along the Southern line of said St. Michael Street to a point; thence South 31 degrees 25 minutes 00 seconds West 165.16 feet along the Northern prolongation of the Eastern line of property described in deed to Cletus A. Presnell and wife, recorded in Book 6771 page 1889 of the St. Louis County Records to its Northeastern corner; thence North 58 degrees 35 minutes 00 seconds West 285.54 feet along the Northern line of said Cletus Presnell property, the Northern line of property described in deed to Edward L. Presnell and wife, recorded in Book 6121 page 225 of the St. Louis County Records, and the Northern line of property described in deed to William Seigel and wife, recorded in Book 6371 page 1588 of the St. Louis County Records to the Eastern line of said 20 foot wide strip; thence North 36 degrees 50 minutes 00 seconds East 165.24 feet along said 20 foot wide strip to the point of beginning.

Subject to existing building lines, easements, conditions, and restrictions now of record if any,

Locator: 07J110802

St. Louis County Map

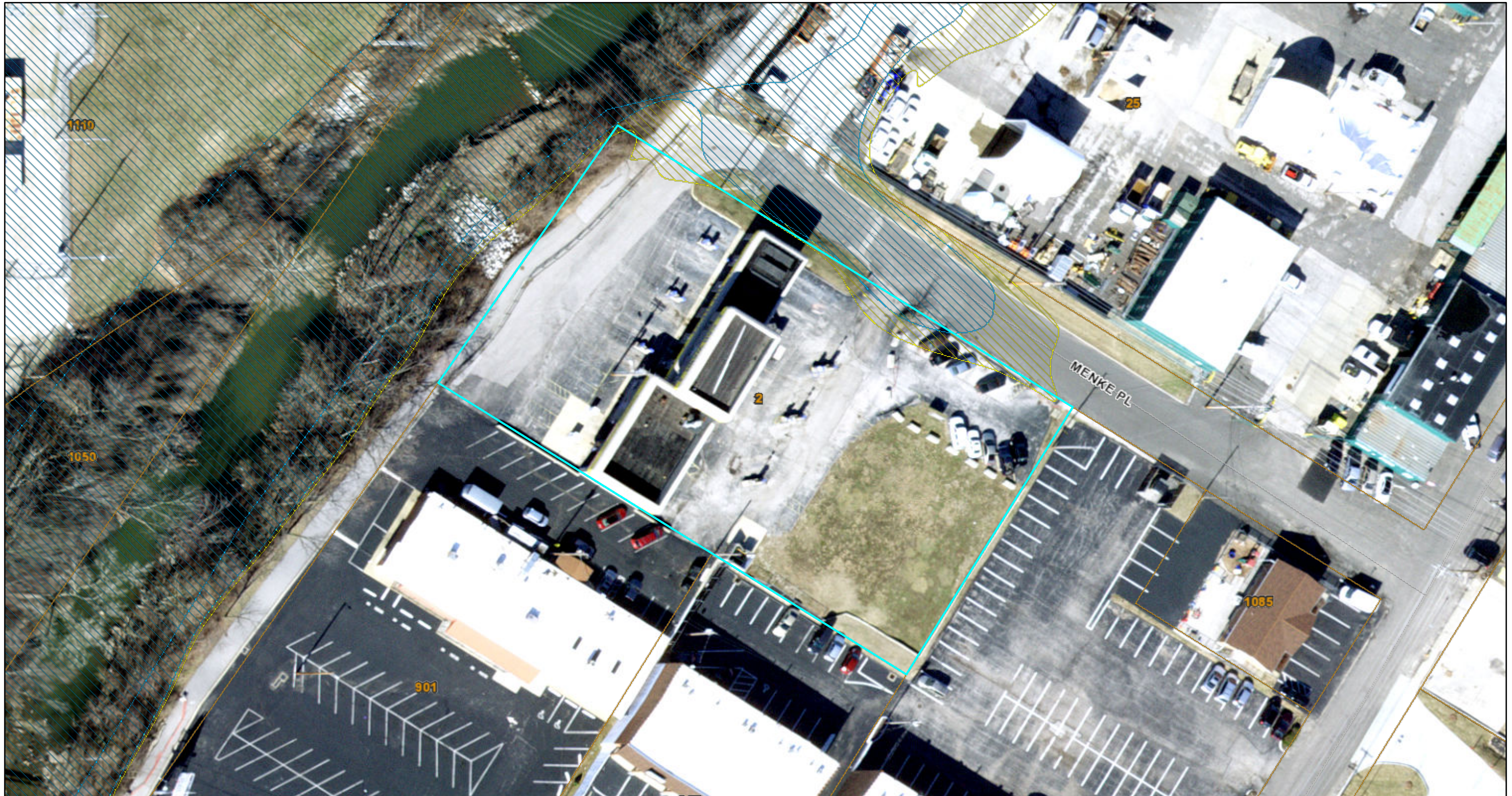

12/6/2021, 9:44:56 AM

Image

Red: Band_1

Green: Band_2

Blue: Band_3

Other Flood Areas (0.2% Annual Chance)

Special Flood Hazard Areas (1% Annual Chance)

1:600

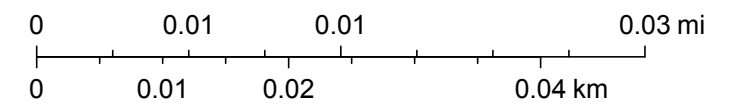

St. Louis County GIS Service Center

FLORISSANT CITY COUNCIL

AGENDA REQUEST FORM

Date: 12/3/21

Mayor's Approval:

Agenda Date Requested: 12/13/2021

Description of request:

Council approval of an ordinance to authorize Mayor Lowery to accept the real estate property located at 2 Menke Place, Florissant, MO 63031.

Department: Economic Development

Recommending Board or Commission: N/A

Type of request:

Ordinances		Other	
Appropriation		Liquor License	
Transfer		Hotel License	
Zoning Amendment		Special Presentations	
CD Amendment		Resolution	X
Special Use Transfer		Proclamation	
Special Use		Subdivision	
Budget Amendment			

Public Hearing needed: **Yes / No** Yes 3 readings? : **Yes / No** Yes

Back up materials attached:		Back up materials needed:	
Minutes		Minutes	
Maps		Maps	
Memo		Memo	
Draft Ord.		Draft Ord.	

Note: Please include all attachments necessary for documents to be generated for inclusion on the Agenda. All agenda requests are to be turned in to the City Clerk by 5pm on Tuesday prior to the Council meeting.

For City Clerk Use Only:
 Introduced by: _____
 PH Speaker: _____

1 INTRODUCED BY COUNCILMAN SCHILDROTH
2 DECEMBER 13, 2021

3
4 BILL NO. 9749 ORDINANCE NO.

5
6 **AN ORDINANCE AUTHORIZING THE MAYOR TO ENTER INTO AN**
7 **AGREEMENT TO ACCEPT OWNERSHIP ON BEHALF OF THE CITY**
8 **OF FLORISSANT OF REAL ESTATE PROPERTY LOCATED AT 2**
9 **MENKE PLACE, AS GIFTED TO THE CITY.**

10
11 WHEREAS, the City has been offered the property known and numbered as 2
12 Menke Place as a gift, and

13
14 WHEREAS, under the City Charter the City Council must authorize the
15 acceptance of any gift of real estate.

16
17 BE IT ORDAINED BY THE COUNCIL OF THE CITY OF FLORISSANT, ST. LOUIS
18 COUNTY, MISSOURI, AS FOLLOWS:

19
20 Section 1: The Mayor of the City of Florissant is hereby authorized to accept ownership
21 of real estate property located at 2 Menke Place, as gifted to the City of Florissant by Asher
22 Rohra and described as follows and according to the survey attached hereto:

23 In the County of St. Louis, State of Missouri:

24
25 A tract of land being part of Lots 110 and 112 of the New Town of St. Ferdinand, according to the plat
26 thereof recorded in Plat Book 5 page 1 of the City of St. Louis (former County) Records, and in Township
27 47 North, Range 6 East, City of Florissant, Missouri, said tract being more particularly described as
28 follows: Beginning at a point of intersection of the Southern line of St. Michael Street, 42.75 feet wide,
29 with the Eastern line of a 20 foot wide strip described in deed to the City of Florissant, recorded in Book
30 1701 page 74 of the St. Louis County Records; thence South 58 degrees 43 minutes 20 seconds East
31 269.94 feet along the Southern line of said St. Michael Street to a point; thence South 31 degrees 25
32 minutes 00 seconds West 165.16 feet along the Northern prolongation of the Eastern line of property
33 described in deed to Cletus A. Presnell and wife, recorded in Book 6771 page 1889 of the St. Louis
34 County Records to its Northeastern corner; thence North 58 degrees 35 minutes 00 seconds West
35 285.54 feet along the Northern line of said Cletus Presnell property, the Northern line of property
36 described in deed to Edward L. Presnell and wife, recorded in Book 6121 page 225 of the St. Louis
37 County Records, and the Northern line of property described in deed to William Seigel and wife,
38 recorded in Book 6371 page 1588 of the St. Louis County Records to the Eastern line of said 20 foot wide
39 strip; thence North 36 degrees 50 minutes 00 seconds East 165.24 feet along said 20 foot wide strip to
40 the point of beginning.

41 Subject to existing building lines, easements, conditions, and restrictions now of record if any,

42 Locator: 07J110802

43
44 Section 2: This ordinance shall become in force and effect immediately upon its passage
45 and approval.

46
47
48
49
50
51
52
53
54
55
56
57
58
59
60
61
62
63
64
65
66
67

Adopted this _____ day of _____, 2021.

Keith Schildroth
President of the Council
City of Florissant

Approved this _____ day of _____, 2021.

Timothy J. Lowery
Mayor, City of Florissant

ATTEST:

Karen Goodwin, MPPA/MMC/MRCC
City Clerk

1 INTRODUCED BY COUNCILMAN EAGAN
2 DECEMBER 13, 2021

3
4 BILL NO. 9750

ORDINANCE NO.

5

6 **ORDINANCE AUTHORIZING A TRANSFER OF SPECIAL USE**
7 **PERMIT NO. 7356 FROM THE BECK GROUP LLC D/B/A LITTLE**
8 **CAESAR’S PIZZA TO CLOTGOTT ENTERPRISES, LLC D/B/A LITTLE**
9 **CAESAR’S PIZZA FOR THE OPERATION OF A RESTAURANT**
10 **LOCATED AT 340 HOWDERSHELL ROAD.**

11

12

13 WHEREAS, the Florissant Zoning Ordinance authorizes the Council of the City of
14 Florissant, by Special Use Permit, after public hearing thereon, to permit the location of a
15 restaurant; and

16 WHEREAS special use permit no. 7356 was granted to the Beck Group, LLC d/b/a Little
17 Caesar’s for the location of a restaurant located at 340 Howdershell ; and

18 WHEREAS Clotgott Enterprises, LLC d/b/a Little Caesar’s Pizza has filed an application
19 to transfer special use permit no. 7356 to its name; and

20 WHEREAS, the City Council of the City of Florissant determined at its meeting on
21 December 13th, 2021 that the business would be operated in substantially identical fashion as set
22 out herein; and

23 WHEREAS, Clotgott Enterprises, LLC d/b/a Little Caesar’s Pizza has accepted the terms
24 and conditions as they apply to a special use permit for a restaurant.

25 **NOW, THEREFORE, BE IT ORDAINED BY THE COUNCIL OF THE CITY OF**
26 **FLORISSANT, ST. LOUIS COUNTY, MISSOURI, AS FOLLOWS:**

27 Section 1: Special use no. 7356 is hereby transferred from Beck Group, LLC d/b/a Little
28 Caesar’s to Clotgott Enterprises, LLC d/b/a Little Caesar’s Pizza for the location of a restaurant
29 located at 340 Howdershell.

30 Section 2: The Special Use Permit herein authorized shall terminate if the said business
31 ceases operation for a period of more than ninety (90) days.

32 Section 3: This ordinance shall become in force and effect immediately upon its passage
33 and approval.

34

35 .

36 Adopted this _____ day of _____, 2021.

37 _____

38 Keith Schildroth

39 Council President

40

41 Approved this _____ day of _____, 2021.

42 _____

43 Timothy J. Lowery

44 Mayor, City of Florissant

45

46

47 ATTEST:

48

49 _____

50 Karen Goodwin, MPPA/MMC/MRCC

51 City Clerk

TRANSFER OF SPECIAL PERMIT

AUTHORIZED BY ORDINANCE NUMBER (S) 7356

FROM Beck Group LLC DBA Little Caesar Pizza
TO Clotgott Enterprises LLC DBA Little Caesar Pizza
FOR location and operation of a restaurant with carryout service
ADDRESS 340 Hawdeshell Road
Ward 3 Zoning R-3 Date Filed 12/8/24 Accepted By [Signature]

TRANSFER OF SPECIAL USE PERMIT PETITION

TO THE CITY COUNCIL OF THE CITY OF FLORISSANT:

1. Comes now Geoff Clotfelle (Clotgott Ent. LLC) ^{owner} and states to the City Council that he (she) (they) has (have) the following legal interest in the property located at 340 Hawdeshell in the City of Florissant, Missouri. Legal interest: Lease or Simple Title
 (Attach signed copy of lease or deed)
2. The petitioner(s) further state that he (she) (they) has (have) not made any arrangement to pay any commission, gratuity, or consideration, directly or indirectly to any official, employee, or appointee of the City of Florissant, with respect to this petition.
3. The applicant will operate the business in the same manner and under the same conditions as set out in the original ordinance granting the special permit or any amendments thereto, except for any proposed change in sign face of an authorized sign.

PETITIONER SIGNATURE Geoffrey Clotfelle
Individual's Name

FOR: Clotgott Enterprises, LLC
Company, Corporation, Partnership

TRANSFER OF SPECIAL USE PERMIT

The undersigned hereby acknowledges receipt of a copy of Ordinance
Number 7356 which previously authorized a Special Use Permit:

TO: Beck Group LLC

FOR: Little Caesars Pizza

Located at: 340 Handshell, Farmington, mo

and agree to the terms and conditions listed in said ordinance and to any
additional term and conditions that the City Council shall deem appropriate.

Geoffrey Clotfelter

PRINT - NAME OF APPLICANT



SIGNATURE OF APPLICANT

4. I (we) hereby certify that (indicate **one only**):

- I (we) have a legal interest in the above described property.
 I am (we are) the duly appointed agent (s) of the petitioner, and that all information given is true and a statement of fact.

SIGNATURE



ADDRESS 1245 E Ogden Ct. Springfield, Mo 65803

Telephone No. 417 838 1332 Email address dotgett@mm.com

I (we) the petitioner(s) do hereby appoint Geoff Clute as my (our) duly authorized agent to represent me (us) in regard to this petition.

PETITIONER SIGNATURE

Note: Petitioner or his/her authorized agent will be the only person(s) permitted to make the presentation to the City Council.

5. Acknowledgement and consent of (**current**) owner to Transfer the Special Use Permit.

SIGNATURE OF OWNER

Information sheet to be attached to all requests for Transfer of Special Permit

Type of Operation: (Select One)

Individual

Partnership

Corporation

LLC

INDIVIDUAL:

Name & address _____

Telephone number & email address _____

Business name/address/phone _____

Copy of fictitious name registration, if applicable _____

PARTNERSHIP:

Name & address of partner (s) _____

Telephone number(s) and email address (s) _____

Business name/ address /phone _____

Copy of fictitious name registration, if applicable _____

CORPORATION OR LLC:

Name & address of all corporate officers _____

Kathleen Clotfelter 3791 N. Vermont Springfield Mo 65802 *Geoff Clotfelter (Managing member) 1245 E Ogden, Springfield, Mo 65803*
James Gott - 3753 N. Oakport Springfield, Mo 65803

Telephone numbers & email addresses _____

Business name/address/phone _____

Little Caesars Pizza / 340 Hendershell / 314-839-9555
Flonssmit, Mo 63031

Photocopy of Corporation/LLC Articles and Certificate _____

Date of incorporation/LLC 3/27/2006

Copy of fictitious name registration, if applicable _____

Copy of latest Missouri Anti-Trust affidavit (annual registration of corporate officers) _____



State of Missouri
Robin Carnahan, Secretary of State

Corporations Division
P.O. Box 778 / 600 W. Main Street, Rm 322
Jefferson City, MO 65102

File Number: 200608653404
LC0726992
Date Filed: 03/27/2006
Robin Carnahan
Secretary of State

Articles of Organization
(Submit with filing fee of \$105)

1. The name of the limited liability company is:
Clotgott enterprises, LLC
(Must include "Limited Liability Company," "Limited Company," "LC," "L.C.," "L.L.C.," or "LLC")

2. The purpose(s) for which the limited liability company is organized: Franchise food service

3. The name and address of the limited liability company's registered agent in Missouri is:
Geoffrey D. Clotfelter 324 S. Suburban Springfield, MO 65802
Name Street Address: May not use P.O. Box unless street address also provided City/State/Zip

4. The management of the limited liability company is vested in: managers members (check one)

5. The events, if any, on which the limited liability company is to dissolve or the number of years the limited liability company is to continue, which may be any number or perpetual: ~~5 years~~ perpetual

(The answer to this question could cause possible tax consequences, you may wish to consult with your attorney or accountant)

6. The name(s) and street address(es) of each organizer (P.O. Box may only be used in addition to a physical street address):
(Organizer(s) are not required to be member(s), manager(s) or owner(s))
Geoffrey D. Clotfelter 324 S. Suburban Springfield, MO 65802
James L. Gott 3753 N. Oak Point Springfield, MO 65803
Kathleen M. Clotfelter 3791 Vera Cruz Springfield, MO 65803

7. The effective date of this document is the date it is filed by the Secretary of State of Missouri, unless you indicate a future date, as follows: n9
(Date may not be more than 90 days after the filing date in this office)

In Affirmation thereof, the facts stated above are true and correct:
(The undersigned understands that false statements made in this filing are subject to the penalties provided under Section 575.040, RSMo)

	Geoffrey D Clotfelter	3/22/06
<small>Organizer Signature</small>	<small>Printed Name</small>	<small>Date</small>
	JAMES L. GOTT	3/22/06
<small>Organizer Signature</small>	<small>Printed Name</small>	<small>Date</small>
	Kathleen M Clotfelter	3/22/06
<small>Organizer Signature</small>	<small>Printed Name</small>	<small>Date</small>

Name and address to return filed document:
Name: _____
Address: _____
City, State, and Zip Code: _____

State of Missouri
Creation - LLC/LP 1 Page(s)



T0608655026



State of Missouri

John R. Ashcroft, Secretary of State

Corporations Division
PO Box 778 / 600 W. Main St., Rm. 322
Jefferson City, MO 65102

X001705886
Date Filed: 9/30/2021
Expiration Date: 9/30/2026
John R. Ashcroft
Missouri Secretary of State

Registration of Fictitious Name

(Submit with filing fee of \$7.00)
(Must be typed or printed)

This information is for the use of the public and gives no protection to the name being registered. There is no provision in this Chapter to keep another person or business entity from adopting and using the same name. The fictitious name registration expires 5 years from the filing date. (Chapter 417, RSMo)

Please check one box:

New
[checked] Registration [] Renewal [] Amendment [] Correction
Charter number Charter number Charter number

The undersigned is doing business under the following name and at the following address:

Business name to be registered: Little Caesars Pizza
Business Address: 1245 E Ogorman Ct
(P.O. Box may only be used in addition to a physical street address)
City, State and Zip Code: Springfield, MO 65803-8094

Owner Information:

If a business entity is an owner, indicate business name and percentage owned. If all parties are jointly and severally liable, percentage of ownership need not be listed. Please attach a separate page for more than three owners. The parties having an interest in the business, and the percentage they own are:

Table with 6 columns: Name of Owners, Individual or Business Entity, Charter # Required If Business Entity, Street and Number, City and State, Zip Code, If Listed, Percentage of Ownership Must Equal 100%. Row 1: Clotgott enterprises, LLC, LC0726992, 5028 N. Farm Road 159, Springfield, MO, 65803, 100.00

All owners must affirm by signing below

In Affirmation thereof, the facts stated above are true and correct:
(The undersigned understands that false statements made in this filing are subject to the penalties of a false declaration under Section 575.060 RSMo)

Clotgott enterprises, LLC - Geoff Clotfelter CLOTGOTT ENTERPRISES, LLC - GEOFF
Owner's Signature or Authorized Signature of Business Entity CLOTFELTER
Date 09/30/2021

Name and address to return filed document:
Name: Geoff clotfelter
Address: Email: clotgott@msn.com
City, State, and Zip Code:



State of Missouri
John R. Ashcroft, Secretary of State
 Corporations Division
 PO Box 778 / 600 W. Main St., Rm. 322
 Jefferson City, MO 65102

X001705886
Date Filed: 9/30/2021
Expiration Date: 9/30/2026
John R. Ashcroft
Missouri Secretary of State

Registration of Fictitious Name

(Submit with filing fee of \$7.00)
(Must be typed or printed)

This information is for the use of the public and gives no protection to the name being registered. There is no provision in this Chapter to keep another person or business entity from adopting and using the same name. The fictitious name registration expires 5 years from the filing date. (Chapter 417, RSMo)

Please check one box:

New Registration **Renewal** _____ *Charter number* **Amendment** _____ *Charter number* **Correction** _____ *Charter number*

The undersigned is doing business under the following name and at the following address:

Business name to be registered: Little Caesars Pizza
 Business Address: 1245 E Ogorman Ct
(PO Box may only be used in addition to a physical street address)
 City, State and Zip Code: Springfield, MO 65803-8094

Owner Information:

If a business entity is an owner, indicate business name and percentage owned. If all parties are jointly and severally liable, percentage of ownership need not be listed. Please attach a separate page for more than three owners. The parties having an interest in the business, and the percentage they own are:

Name of Owners, Individual or Business Entity	Charter # Required If Business Entity	Street and Number	City and State	Zip Code	If Listed, Percentage of Ownership Must Equal 100%
Clotgott enterprises, LLC	LC0726992	5028 N. Farm Road 159	Springfield, MO	65803	100.00

All owners must affirm by signing below

In Affirmation thereof, the facts stated above are true and correct:

(The undersigned understands that false statements made in this filing are subject to the penalties of a false declaration under Section 575.060 RSMo)

<u>Clotgott enterprises, LLC - Geoff Clotfelter</u> <i>Owner's Signature or Authorized Signature of Business Entity</i>	<u>CLOTGOTT ENTERPRISES, LLC - GEOFF CLOTFELTER</u> <i>Printed Name</i>	<u>09/30/2021</u> <i>Date</i>
--	--	----------------------------------

Name and address to return filed document:

Name: Geoff clotfelter

Address: Email: clotgott@msn.com

City, State, and Zip Code: _____

1 INTRODUCED BY COUNCILMAN SCHNEIDER
2 NOVEMBER 13, 2006

3
4
5 SUBSTITUTE BILL NO. 8269

ORDINANCE NO. 7356

6
7 **AN ORDINANCE GRANTING A SPECIAL USE PERMIT TO BECK**
8 **GROUP, LLC D/B/A LITTLE CAESARS PIZZA TO ALLOW FOR THE**
9 **LOCATION AND OPERATION OF A RESTAURANT FOR THE**
10 **PROPERTY LOCATED AT 340 HOWDERSHELL ROAD.**
11

12
13 WHEREAS, the Florissant Zoning Ordinance authorizes the City Council of the City of
14 Florissant, by Special Use Permit, after public hearing thereon, to permit the location and
15 operation of a restaurant; and

16 WHEREAS, an application has been filed by Beck Group, LLC d/b/a Little Caesars Pizza
17 to allow for the location and operation of a restaurant on the property known as 340
18 Howdershell Road; and

19 WHEREAS, the Planning and Zoning Commission of the City of Florissant, at their
20 meeting of October 16, 2006, has recommended that the said Special Use Permit be granted; and

21 WHEREAS, due notice of a public hearing on said application to be held on the 13th of
22 November, 2006 at 8:00 P.M. by the Council of the City of Florissant was duly published, held
23 and concluded; and

24 WHEREAS, the City Council, following said public hearing, and after due and careful
25 consideration, has concluded that the granting of the Special Use Permit as hereinafter provided
26 would be in the best interest of the City of Florissant but the City Council believes that no
27 additional restaurant operations should be allowed at this location.

28 NOW, THEREFORE, BE IT ORDAINED BY THE COUNCIL OF THE CITY OF
29 FLORISSANT, ST. LOUIS COUNTY, MISSOURI, AS FOLLOWS:
30

31 Section 1: A Special Use Permit is hereby granted to Beck Group, LLC d/b/a Little
32 Caesars Pizza to allow for the location and operation of a restaurant with carryout service on
33 the property known as 340 Howdershell Road per drawings submitted.

34 Section 2: The said Special Use Permit herein authorized shall remain in full force and
35 effect and subject to all of the ordinances of the City of Florissant.

State of Missouri



Robin Carnahan
Secretary of State

CERTIFICATE OF ORGANIZATION

WHEREAS,

Clotgott enterprises, LLC
LC0726992

filed its Articles of Organization with this office on the 27th day of March, 2006, and that filing was found to conform to the Missouri Limited Liability Company Act.

NOW, THEREFORE, I, ROBIN CARNAHAN, Secretary of State of the State of Missouri, do by virtue of the authority vested in me by law, do certify and declare that on the 27th day of March, 2006, the above entity is a Limited Liability Company, organized in this state and entitled to any rights granted to Limited Liability Companies.

IN TESTIMONY WHEREOF, I have set my hand and imprinted the GREAT SEAL of the State of Missouri, on this, the 27th day of March, 2006.

Robin Carnahan

Secretary of State

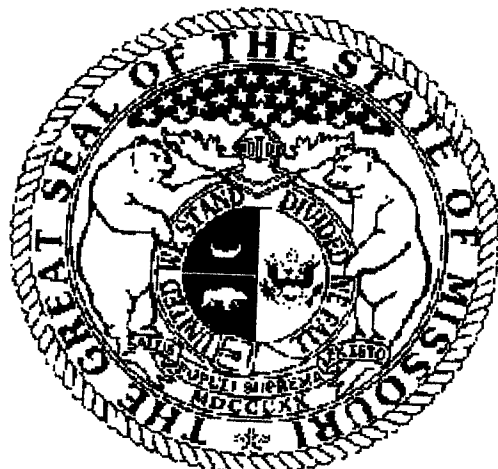

1 INTRODUCED BY COUNCILMAN SCHILDROTH
2 DECEMBER 13, 2021

3
4 BILL NO. 9751

ORDINANCE NO.

5
6 **AN ORDINANCE AMENDING ORDINANCE NO. #8743 ESTABLISHING**
7 **A NEW COMPENSATION PLAN FOR SEASONAL EMPLOYEES OF**
8 **THE CITY OF FLORISSANT TO ALLOW FOR A CORRECTION.**

9
10 BE IT ORDAINED BY THE COUNCIL OF THE CITY OF FLORISSANT, ST. LOUIS
11 COUNTY, MISSOURI, AS FOLLOWS:

12
13 Section 1: Ordinance No. 8743 is hereby amended to allow for a correction for the
14 position listed as follows:

	Grade	Start	Year 2	Year 3	Year 4	Year 5
Golf Food & Beverage Manager						
Golf Pro Shop Manager	S8	\$12.50	\$13.35	\$13.62	\$13.89	\$14.17

15
16
17 Section 3: This ordinance shall become in force and effect as of January 1, 2022.

18
19 Adopted this ____ day of _____, 2021.

20
21
22 _____
23 Keith Schildroth
24 President of the Council
25 City of Florissant

26
27
28 Approved this ____ day of _____, 2021.

29
30
31 _____
32 Timothy J. Lowery
33 Mayor, City of Florissant

34 ATTEST:
35
36 _____
37 Karen Goodwin, MPPA/MMC/MRCC
City Clerk

FLORISSANT CITY COUNCIL

AGENDA REQUEST FORM

Date: 12/08/21 _____

Mayor's Approval:

Agenda Date Requested:

12/13/2021

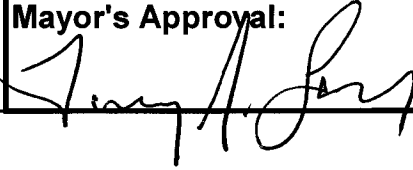

Description of request:

Correction to Seasonal ordinance for Golf Food & Beverage Manager and Golf Pro Shop

Manager rates.

Department: Human Resources

Recommending Board or Commission:

Type of request:

Ordinances	X	Other	X
Appropriation		Liquor License	
Transfer		Hotel License	
Zoning Amendment		Special Presentations	
Amendment	X	Resolution	
Special Use Transfer		Proclamation	
Special Use		Subdivision	
Budget Amendment			

Y/N

Y/N

Public Hearing needed: **Yes / No**

N

3 readings? : **Yes / No**

Y

Back up materials attached:

Back up materials needed:

Minutes		Minutes	
Maps		Maps	
Memo	X	Memo	
Draft Ord.	X	Draft Ord.	

Note: Please include all attachments necessary for documents to be generated for inclusion on the Agenda. All agenda requests are to be turned in to the City Clerk by 5pm on Tuesday prior to the Council meeting.

For City Clerk Use Only:

Introduced by: _____

PH Speaker: _____



MEMORANDUM

Date: December 8, 2021
To: Mayor Timothy J. Lowery and City Council
From: Sonya D. Brooks-White, Director of Human Resources
Re: Correction: Seasonal Employees Ordinance

Would like to request an amendment to the Seasonal Employees pay ordinance. A correction needs to be made to the ordinance for the following grade and positions to reflect the rates below:

Golf Food & Beverage Manager
Golf Pro Shop Manager

Grade	Start	Year 2	Year 3	Year 4	Year 5
S8	12.50	13.35	13.62	13.89	14.17

If you need additional information or have any questions feel free to contact me at 314-839-7623 or email swhite@florissantmo.com