



## **FLORISSANT CITY COUNCIL AGENDA**

**City Hall**

**955 rue St. Francois**

**Tuesday, February 28, 2017**

**7:30 PM**

**Karen Goodwin, MMC/MRCC**



### **I. PLEDGE OF ALLEGIANCE**

### **II. ROLL CALL OF MEMBERS**

### **III. APPROVAL OF MINUTES**

- Meeting Minutes and Executive Minutes of February 13, 2017
- Workshop minutes of January 30, 2017

### **IV. HEARING FROM CITIZENS**

(Speaker cards are available at the entrance to the Council Chambers)

### **V. COMMUNICATIONS**

- 1 Email dated February 13, 2017 from Niki Featherly requesting the repeal of the pit bull ban.
- 2 Email dated February 13, 2017 from Sandra Link requesting the repeal of the pit bull ban.
- 3 Email dated February 13, 2017 from Jenny Traux requesting the repeal of the pit bull ban
- 4 Email dated February 14, 2017 from Mike and Stephanie Cawvey requesting the repeal of the pit bull ban.
- 5 Email dated February 14, 2017 from Thelma Jean Schaefer requesting the repeal of the pit bull ban.
- 6 Email dated February 14, 2017 from Daniel Johnson requesting the repeal of the pit bull ban.
- 7 Email dated February 13, 2017 from Kim Orf requesting the repeal of the pit bull ban.
- 8 Email dated February 12, 2017 from Mindy Rouff requesting the repeal of the pit bull ban
- 9 Email dated February 12, 2017 from Matt Beeman requesting the repeal of the pit bull ban.
- 10 Email dated February 11, 2017 from Lacey Knox requesting the repeal of the pit bull ban.
- 11 Email dated February 10, 2017 from Theresa Schmidt requesting the repeal of the pit bull ban.
- 12 Email dated February 10, 2017 from Christie Lenox requesting the repeal of the pit bull ban.
- 13 Email dated February 10, 2017 from Michelle Stokes requesting the repeal of the pit bull ban.
- 14 Email dated February 10, 2017 from Stefanie Skaggs requesting the repeal of the pit bull ban.
- 15 Email dated February 10, 2017 from Alma Slemmer requesting the repeal of the pit bull ban.
- 16 Email dated February 14, 2017 from Craig Schoeller requesting the repeal of the pit bull ban.
- 17 Email dated February 15, 2017 from Rhiannon Fryer requesting the repeal of the pit bull ban.
- 18 Email dated February 14, 2017 from John Roth requesting the repeal of the pit bull ban.

- 19 Email dated February 21, 2017 from Terry Hoppes-Hulcer expressing support of the pit bull ban.
- 20 Email dated February 20, 2017 from Mary Wacker requesting the repeal of the pit bull ban.
- 21 Email dated February 20, 2017 from David and Letha Counts expressing support of the pit bull ban.
- 22 Email dated February 20, 2017 from Samantha Scarfino requesting the repeal of the pit bull ban.
- 23 Email dated February 20, 2017 from Marilyn Mayfield requesting the repeal of the pit bull ban.
- 24 Email dated February 20, 2017 from Amber Fox requesting the repeal of the pit bull ban.
- 25 Email dated February 20, 2017 from Cindi O'Shea expressing support of the pit bull ban.
- 26 Email dated February 19, 2017 from Christina Hoxworth requesting the repeal of the pit bull ban.
- 27 Email dated February 19, 2017 from Kristina Curnutt requesting the repeal of the pit bull ban.
- 28 Email dated February 19, 2017 from Frank Bougher requesting the repeal of the pit bull ban.
- 29 Email dated February 15, 2017 from Joni Chester requesting the repeal of the pit bull ban.
- 30 Email dated February 15, 2017 from Bob Levin expressing support of the pit bull ban.
- 31 Email dated February 21, 2017 from Constance Harge expressing support of the pit bull ban.
- 32 Email dated February 21, 2017 from William and Robin Johnson expressing support of the pit bull ban.
- 33 Email dated February 21, 2017 from Jennifer Storace requesting the repeal of the pit bull ban.
- 34 Letter dated February 20, 2017 from Brian Griesemer expressing support of the pit bull ban.
- 35 Email dated February 22, 2017 from Kristin Korte requesting the repeal of the pit bull ban.
- 36 Email dated February 21, 2017 from Cheryl Smith expressing support of the pit bull ban.
- 37 Email dated February 21, 2017 from Shiela Swindle requesting the repeal of the pit bull ban.
- 38 Email dated February 22, 2017 from Debbie Causevic requesting the repeal of the pit bull ban.
- 39 Email dated February 21, 2017 from Ken Pruett requesting the repeal of the pit bull ban.
- 40 Email dated February 21, 2017 from Cheryl Genail requesting the repeal of the pit bull ban.
- 41 Email dated February 21, 2017 from Nikki Weiss requesting the repeal of the pit bull ban.
- 42 Email dated February 22, 2017 from Amanda Heger requesting the repeal of the pit bull ban.
- 43 Email dated February 22, 2017 from Bob, Garalyn, Molly, Benjamin and Brendan Farmer expressing support for the pit bull ban.
- 44 Email dated February 22, 2017 from Yvonne Wolf requesting the repeal of the pit bull ban.

## **VI. PUBLIC HEARINGS**

17-02-005 (Ward 9) Application Staff Report Plans	Request to authorize an amendment to Special Use Permit No. 8029 to Burger King to allow for renovations to the existing building in a B-3 Zoning district for the property located at 3121 N. Highway 67. (Planning and Zoning Commission recommended approval with stipulations on 2/6/17)	Bart Berneking
14-02-006 (Ward 3) Application Staff Report Plans	Request to authorize a Special Use permit to STL Howdershell, LLC d/b/a St. Louis Fish & Chicken to allow for a carry-out restaurant for the property located at 340-A Howdershell Rd. (Planning and Zoning Commission recommended approval on 2/6/17)	Muath Salameh

**VII. OLD BUSINESS**

**A. SECOND READINGS**

---

9256 Application Staff Rpt Plans	Ordinance to authorize an amendment to Special Use Permit no. 7398 to allow for exterior alterations for the property located at 1261 Graham Road. (continued to this date on February 13, 2017)	2 <sup>nd</sup> Reading Schildroth
9257	Ordinance to authorize an amendment to B-5 Ordinance No. 6868 to allow for a new sit-down carry-out restaurant with signage for the property located at 2180 N. Highway 67.	2 <sup>nd</sup> Reading Siam
9258 Memo	Ordinance amending the general fund budget to reflect \$85,000 from asset forfeiture funds in escrow to forfeiture revenue account 01-4-34511 and to the forfeiture expenditure account 01-5-49-61000 for various police department expenditures.	2 <sup>nd</sup> Reading Pagano
9259	Ordinance authorizing a transfer of Special Use Permit 7716 from Tot Lots Learning Center to Florissant Kids Care Center LLC for the operation of a day care located at 2184 N. Waterford Drive.	2 <sup>nd</sup> Reading Siam
S9260	Ordinance amending Title II Chapter 205 by amending Section 205.395 "Regulation Of Pit Bull Dogs" to allow pit bull dogs in the city with mandatory spaying and neutering.	2 <sup>nd</sup> Reading Pagano, Caputa
9261	Ordinance amending Title II Chapter 205 by amending section 205.260 "Dangerous Animals".	2 <sup>nd</sup> Reading Pagano, Caputa
9262 Memo	Ordinance amending revenue account no. 3490 "Grants and Reimbursements" in the amount of \$9,780 and appropriating the sum of \$9,780 from the General Revenue Fund to budget account no. 4921 "Uniforms" to purchase ballistic vests awarded through a local law enforcement block grant.	2 <sup>nd</sup> Reading Pagano

---

**VIII. NEW BUSINESS**

**IX. BOARD APPOINTMENTS**

**X. REQUESTS**

---

Ward 6 Application	Request for a Malt Liquor & Wine by the Drink license for Amore Pizza, LLC located at 450 rue St. Francois St.	Derick Wellman
-----------------------	--	-------------------

---

---

Ward 5 Request for Malt Liquor & Wine by the Drink license for Jimmie White  
Application Alexandria's Wine Cellar located at 150 Washington St.

---

**XI. BILLS FOR FIRST READING**

---

9263 Ordinance to authorize an amendment to Special Use Permit Siam  
No. 8029 to Burger King to allow for renovations to the  
existing building in a B-3 Zoning district for the property  
located at 3121 N. Highway 67.

---

9264 Ordinance to authorize a Special Use permit to STL Eagan  
Howdershell, LLC d/b/a St. Louis Fish & Chicken to allow for  
a carry-out restaurant for the property located at 340-A  
Howdershell Rd.

---

9265 Ordinance authorizing the re-painting of masonry for Church's Henke  
Plans Chicken located at 410 N. Highway 67.

---

**XII. COUNCIL ANNOUNCEMENTS**

**XIII. MESSAGE FROM THE MAYOR**

**XIV. ADJOURNMENT**

**THIS AGENDA WAS POSTED AT THE FLORISSANT CITY HALL FEBRUARY 24, 2017 AT 12:00 PM ON THE BULLETIN BOARD OUTSIDE THE COUNCIL CHAMBERS. ANY ONE WISHING TO ATTEND THE COUNCIL MEETING WHO HAS SPECIAL NEEDS SHOULD CONTACT THE CITY CLERK'S OFFICE AT 839-7630 OR TDD 839-5142 BY NOON ON TUESDAY, FEBRUARY 28, 2017.**



1

# CITY OF FLORISSANT

2



3

## COUNCIL MINUTES

4

5

6

7

8

February 13, 2017

9

10

11 The Florissant City Council met in regular session at Florissant City Hall, 955 rue St. Francois  
12 on Monday, February 13, 2017 at 7:30 p.m. with Council President Pagano presiding. The Chair asked  
13 everyone in attendance to stand and join in the Pledge of Allegiance.

14 On Roll Call the following Councilmembers were present: Eagan, Caputa, Schildroth, Pagano,  
15 Schmidt, Siam, Lee and Jones. Councilman Henke was excused. Also present was Mayor Thomas P.  
16 Schneider, City Attorney John Hessel and City Clerk Karen Goodwin. A quorum being present the  
17 Chair stated that the Council Meeting was in session for the transaction of business.

18 Councilman Lee moved to approve the Meeting Minutes of 1/23/17, seconded by Eagan.  
19 Motion carried.

20 The Chair stated that the next item on the agenda was *Hearing from Citizens* and asked any  
21 citizen who wished to speak to come forward.

22  
23 Jessica Ponder, 1480 St. Catherine, introduced herself to the residents of Florissant. She is a  
24 candidate for the upcoming election for board member for the Ferguson-Florissant School District.  
25

26 Joshua Polsky, 748 Loekes Dr., recapped information regarding bite statistics relating to the  
27 BSL and its ineffectiveness in controlling dangerous dogs. HB905 has been introduced at the state  
28 legislature and, if passed, will prevent local municipalities from banning specific breeds of dogs.  
29

30 Connie Nolan, 170 Ruth Dr., thanked Councilmembers' Pagano and Caputa for introducing  
31 legislation tonight that would repeal the BSL. The media has not presented an accurate version of pit  
32 bull dogs.  
33

34 Andrea Castleberry, 5414 Blow St., asked the City Council to please repeal the BSL, as  
35 statistics support that it is not effective legislation.  
36

37 Lori Stimac, 3866 Grand National, stated that she owned two wonderful pit bull dogs and they  
38 couldn't be more loving with her family and grandchildren.  
39

40 Robin Brown, 26 St. Laurence, asked the Council to repeal Florissant's breed specific  
41 legislation.  
42

43 Donna Slemmer, 2612 Poe Ave., stated that support for banning pit bulls dogs is not  
44 substantiated by facts. Each dog should be looked at as an individual. Pit bulls are trained and used as  
45 support dogs.  
46

47 Mike Cardenes, 2475 Stoney End Ct, thanked the Council for listening to the FBA and for  
48 introducing the repeal legislation onto the agenda.  
49

50 Angie Schaefer, 2 Robin Ct., stated that she owns two pit bulls, and they were both recently  
51 allowed into Busch stadium for a charity walk. She shared pictures of them getting along with other  
52 dogs and asked the Council to repeal the pit bull ban.  
53

54 Linda Church, 13 McNulty, stated that every community has its laws and people should know  
55 that there is a pit bull ban before they move in. There are pit bulls in the community now that are not  
56 tagged. She questioned whether there would be enough staff to enforce the new legislation.  
57

58 Elizabeth Thurman, 37 Jamestown Farms, stated she has been a veterinarian for 16 years and  
59 understands the emotional issues behind the BSL. She suggested a possible compromise: that pit bull  
60 dogs allowed into Florissant be neutered. Pit bulls are abused, not socialized and used for nefarious  
61 reasons. Their reputation has nothing to do with the inherent breed.  
62

63 John Engelemeyer, 1281 Graham Rd, addressed the asphalt behind Doozles which he felt was in  
64 need of further repair. He addressed the issue of a legacy of the City of Florissant and Florissant's  
65 future.  
66

67  
68 The Chair stated that the next item on the agenda was *Communications*.

- 1 Letter received January 19, 2017 received from Mandy Ryan regarding the repeal of the pit bull ban
- 2 Email dated January 23, 2017 from Gail Scarfino regarding the repeal of the pit bull ban
- 3 Email dated January 23, 2017 from Vickie Rolfes regarding the repeal of the pit bull ban
- 4 Email dated January 23, 2017 from Amy Newton regarding the repeal of the pit bull ban
- 5 Email dated January 23, 2017 from Erin Berghold regarding the repeal of the pit bull ban
- 6 Email dated January 23, 2017 from Heather Dye regarding the repeal of the pit bull ban
- 7 Email dated January 23, 2017 from Brittany Schleicher regarding the repeal of the pit bull ban
- 8 Email dated January 24, 2017 from Andrea Castleberry regarding the repeal of the pit bull ban
- 9 Email dated January 24, 2017 from Laura Wichlinski regarding the repeal of the pit bull ban
- 10 Email dated January 24, 2017 from Mindy Boyer regarding the repeal of the pit bull ban
- 11 Email dated January 24, 2017 from Connie Nolan regarding the repeal of the pit bull ban
- 12 Email dated January 24, 2017 from Sandra Link regarding the repeal of the pit bull ban
- 13 Email dated January 25, 2017 from Becky Keesling regarding the repeal of the pit bull ban
- 14 Email dated January 25, 2017 from Debbie Causevic regarding the repeal of the pit bull ban

- 15 Email dated January 25, 2017 from Melissa Jeffery regarding the repeal of the pit bull ban
- 16 Email dated January 25, 2017 from Tamara Vastine regarding the repeal of the pit bull ban
- 17 Email dated January 25, 2017 from Angie Schaefer regarding the repeal of the pit bull ban
- 18 Email dated January 26, 2017 from Carl Hughes regarding the repeal of the pit bull ban
- 19 Email dated January 25, 2017 from the Staff of Slem's Pet Care regarding repeal of the pit bull ban
- 20 Email dated January 25, 2017 from Donna Slemmer regarding the repeal of the pit bull ban
- 21 Email dated January 26, 2017 from Shawna Walker regarding the repeal of the pit bull ban
- 22 Email dated January 26, 2017 from Cheryl Genail regarding the repeal of the pit bull ban
- 23 Email dated January 30, 2017 from Gail Howell regarding the repeal of the pit bull ban
- 24 Email dated January 30, 2017 from Diane Dedert regarding the repeal of the pit bull ban
- 25 Email dated January 30, 2017 from Dave Wineman regarding the repeal of the pit bull ban
- 26 Email dated January 30, 2017 from Tracy Dedert regarding the repeal of the pit bull ban
- 27 Email dated January 30, 2017 from Andy Wilson regarding the repeal of the pit bull ban
- 28 Email dated January 31, 2017 from Ashley Rhodes regarding the repeal of the pit bull ban
- 29 Email dated January 31, 2017 from Frank Bougher regarding the repeal of the pit bull ban
- 30 Email dated February 1, 2017 from Maryrose Booher regarding the repeal of the pit bull ban
- 31 Email dated February 1, 2017 from Nichole McDonald regarding the repeal of the pit bull ban
- 32 Email dated February 1, 2017 from Judy Richter regarding the repeal of the pit bull ban
- 33 Email dated February 1, 2017 from Kevin McDonald regarding the repeal of the pit bull ban
- 34 Email dated February 2, 2017 from Jennifer Harutunian regarding the repeal of the pit bull ban
- 35 Email dated February 2, 2017 from Cynthiana Echele regarding the repeal of the pit bull ban
- 36 Email dated February 2, 2017 from Kristin Korte regarding the repeal of the pit bull ban
- 37 Email dated February 3, 2017 from Miriam Atlee regarding the repeal of the pit bull ban
- 38 Email dated February 2, 2017 from Jeff Cook regarding Plaza Madrid

69

70

71 *Hearing from Citizens-continued:*

72

73 Cindi O'Shea, 125 W. St. Anthony, vet tech, stated that she had been bit by a pit bull dog. She  
74 felt that blood DNA testing be required for pit bulls.

75

76 Cedric Brown, 1204 St. Jean, stated that he received notification from the City that he must get  
77 rid of his mild mannered terrier. When he and his wife were out of town, the dog's caretaker  
78 accidentally let the dog loose. He asked that the BSL be repealed.

79

80 Amy Harrison, 695 Hargrove, asked that the discriminatory BSL be repealed. She supports  
81 neutering of all dogs.

82

83 Shawnee Rose, 3051 Valley Vista Drive, asked that the BSL be repealed.

84

85 Joan Swanston, 116 Birkdale, stated that Florissant residents, as tax payers, have a right to own  
86 any kind of dog. Throughout recent history, many different breeds of dogs have been deemed  
87 "dangerous" in the court of public opinion - now it is the pit-bull's turn. She asked the Council to  
88 repeal the BSL in Florissant.

89  
90 Theresa Schmidt, 10344 Sannois Dr, asked that the discriminatory BSL be repealed. She feels  
91 irresponsible dog owners are at fault. Many notable organizations oppose the BSL.  
92

93 Larry Appel, 1485 Lindsay, expressed his concern about the speeding and traffic on Lindsay  
94 Lane.

95 Alan Jones, 665 S Skinker, stated that the issue is not that pit bulls bite more frequently, but that  
96 their bite is stronger and does more harm. He supported the BSL.  
97

98 Karon McCoy, 1866 Basket Oak Drive, asked that the BSL be repealed. She has owned a pit  
99 bull for many years and another one is being trained to be a therapy dog.  
100

101 Sean Madden, 93 North Oaks Plaza, informed the residents about the St. Louis Youth  
102 Build/AmeriCorps. This program is a pre-apprentice program for youth who have dropped out of  
103 school and need help getting a GED. They are taught carpentry and construction skills and the program  
104 lasts 8-12 months. It is currently open enrollment time.  
105

106 The next item on the Agenda was Public Hearings.

107 The City Clerk reported that Public Hearing #16-09-026 to be held this night on a request to  
108 rezone for Lyons Properties, LLC d/b/a Dunkin Donuts the property located at 8115 N. Lindbergh from  
109 B-3 "Extensive Commercial District" to B-5 "Planned Commercial District" to allow for the  
110 construction of a new building had been advertised in substantially the same form as appears in the  
111 foregoing publication and by posting the property. The Chair declared the Public Hearing to be open  
112 and invited those who wished to be heard to come forward.

113 Chairman Eagan stated that the petitioner had requested a continuance. Being no citizens who  
114 wished to speak, Councilman Eagan moved to postpone P.H. #16-09-026 to 3/13/2017, seconded by  
115 Jones. Motion carried.

116 The City Clerk reported that Public Hearing #17-02-004 to be held this night on a request to  
117 issue an amendment to B-5 Ordinance No. 6868 to allow for a new sit-down, carry-out restaurant with  
118 signage for the property located at 2180 N. Highway 67 had been advertised in substantially the same  
119 form as appears in the foregoing publication and by posting the property. The Chair declared the  
120 Public Hearing to be open and invited those who wished to be heard to come forward.

121 Michael Mueller, representative for McAlister's, stated that the proposed site is the old Bob  
122 Evans Restaurant on Lindbergh. The existing brick on the building will remain "as is" but they will be  
123 adding a 700 square foot patio on the "bank" side of the building, to be accessed only through the  
124 restaurant. The parking will remain the same. There will be a sidewalk off of the back patio for

125 emergency egress from the patio itself. There is some existing landscaping around the patio which will  
126 be removed and replaced with new landscaping to match existing. Initially staff expressed concern  
127 about traffic coming across the “bank” side onto the patio itself. Mr. Mueller explained that the patio  
128 was 2 feet above the existing grade and Mr. Lum felt that would be sufficient.

129 The brick will remain the same and the red awnings will be replaced with hunter green awnings.  
130 The faux EIFS on the east and west elevations will be painted to match the bronze on the doors at the  
131 back of the building. There will be a new awning located over the patio area. The patio will be smoke  
132 free. The Bob Evans “tower” will be removed and McAlister’s will be put in its place. A sign package  
133 was submitted. The existing red lights on the side of the building will be painted black. The lights will  
134 not flash but will be steady and turned on during business hours only. No traffic study will be  
135 completed as it will be approximately the same as it was Bob Evans. The petitioner stated that the  
136 outside concrete foundation will be painted to match the band of brick above the awnings. The  
137 petitioner didn’t want just a gray concrete slab to be exposed. Bushes will hide the concrete foundation  
138 as well. There will be no drive – thru as this restaurant. The Mayor asked the petitioner to install  
139 pedestrian trash receptacles on the site.

140 The Chair asked if there were any citizens who would like to speak on said public hearing.

141 Linda Church, 13 McNulty, asked if there was any way that a vehicle could hit the patio to  
142 which the petitioner stated no, any traffic would be stopped.

143 Kevin O’Donnell, 512 Rancho Lane, thanked the Mayor and Councilman Eagan for requesting  
144 trash receptacles on site.

145 Mike Cardenes, 2475 Stoney End Ct, thanked McAlister’s for opening a restaurant in Florissant.

146 Being no other citizens who wished to speak, Councilman Siam moved to close P.H. #17-02-  
147 004 seconded by Lee. Motion carried.

148 Councilman Schmidt moved that Bill No. 9255 An Ordinance to authorize an amendment to  
149 Special Use Permit No. 4830, as amended by Ordinance Nos. 5071, 5255 and 5259 for the location of a  
150 ground sign in an R-4 Zoning District for the property located at 1001 Dunn Road be read for a second  
151 time, seconded by Schildroth. Motion carried and Bill No. 9255 was read for a second time.  
152 Councilman Schildroth moved that Bill No. 9255 be read for a third time, seconded by Caputa. Motion  
153 carried and Bill No. 9255 was read for a third and final time and placed upon its passage.

154 Before the final vote all interested persons were given an opportunity to be heard. On roll call  
155 the Council voted: Eagan yes, Caputa yes, Schildroth yes, Henke absent, Pagano yes, Schmidt yes,

156 Siam yes, Lee yes and Jones yes. Whereupon the Chair declared Bill No. 9255 to have passed and  
157 said Bill became Ordinance No. 8295.

158 Councilman Schildroth moved that Bill No. 9256 An Ordinance to authorize an amendment to  
159 Special Use Permit No. 7398 to allow for exterior alternations for the property located at 1261 Graham  
160 Road be continued to 2/28/2017 at the request of the petitioner, seconded by Pagano. Motion carried.

161 Councilman Pagano moved to reappoint Linda Rose, 1080 Wycomb, to the Parks & Recreation  
162 Advisory Board as a member from Ward 7 for a term expiring on 2/28/2020, seconded by Eagan.  
163 Motion carried.

164 Councilman Siam moved to appoint Kalyn Brantley-McNeal, 57 Clubs Grounds North, to the  
165 Personnel Commission as a member from Ward 9 for a term expiring on 12/13/2021, seconded by Lee.  
166 Motion carried.

167 Councilman Lee moved to accept the Mayor's reappointment of Rob Shoemaker, 1440  
168 Thoroughbred Lane, to the Emergency Management Commission as a member from Ward 9 for a term  
169 expiring on 11/14/2020, seconded by Eagan. Motion carried.

170 Councilman Jones moved to accept the Mayor's reappointment of Alan Kennedy, 960 Kostka,  
171 to the Emergency Management Commission as a member from Ward 3 for a term expiring on  
172 1/27/2020, seconded by Eagan. Motion carried.

173 Councilman Jones moved to accept the Mayor's reappointment of Mary Janis, 1135 St. Regis,  
174 to the Emergency Management Commission as a member from Ward 7 for a term expiring on  
175 1/27/2020, seconded by Eagan. Motion carried.

176 Councilman Jones moved to accept the Mayor's reappointment of Eric Thomas, 3725 Estates  
177 Dr., to the Emergency Management Commission as a temporary member from Ward 1 for a term  
178 expiring on 1/11/2018, seconded by Eagan. Motion carried.

179 Councilman Jones moved to accept the Mayor's appointment of Daniel Cunningham, 325  
180 Holiday Hill Dr., to the Emergency Management Commission as a temporary member from Ward 6 for  
181 a term expiring on 2/13/2018, seconded by Eagan. Motion carried.

182 Councilman Jones moved to accept the Mayor's appointment of Seth Gorman, 2020 Flamingo,  
183 to the Youth Advisory Commission as an adult member from Ward 1 for a term expiring on 2/13/2020,  
184 seconded by Eagan. Motion carried.

185 Councilman Jones moved to accept the Mayor's appointment of Kerry Jones, 2318 SuCasa, to  
186 the Youth Advisory Commission as a member from Ward 1 for a term expiring on 2/13/2020, seconded  
187 by Eagan. Motion carried.

188 Councilman Jones moved to accept the Mayor's appointment of Keshon Pulliam, 2302 SuCasa,  
189 to the Youth Advisory Commission as a member from Ward 1 for a term expiring on 2/13/2020,  
190 seconded by Eagan. Motion carried.

191 Councilman Jones moved to accept the Mayor's reappointment of Amanda Gorman (Fox), 2020  
192 Flamingo, to the Youth Advisory Commission as a member from Ward 1 for a term expiring on  
193 2/14/2020, seconded by Eagan. Motion carried.

194 Councilman Jones moved to approve the request for Donna Scholl to keep three hens for the  
195 property located at 1485 Lindsay, seconded by Caputa. Motion carried.

196 Councilman Siam moved to approve the request for a Transfer of Special Use Permit No. 7716  
197 from Tot Lots Learning Center to Florissant Kids Care Center, LLC for the operation of a day care  
198 center located at 2184 N Waterford, seconded by Siam. Motion carried and the request was approved.

199 Council as a Whole introduced Resolution No. 993 A Resolution authorizing the Mayor of the  
200 City of Florissant to make application under the Municipal Parks Grant for planning services at  
201 Manion Park for an inclusive playground and said Resolution was read for the first time. Councilman  
202 Caputa moved that Resolution No. 993 be read for a second time, seconded by Schildroth. Motion  
203 carried and Resolution No. 993 was read for a second time. Councilman Schildroth moved that  
204 Resolution No. 993 be read for a third time, seconded by Schmidt. On roll call the Council voted:  
205 Eagan yes, Caputa yes, Schildroth yes, Henke absent, Pagano yes, Schmidt yes, Siam yes, Lee yes and  
206 Jones yes. Having received the unanimous vote of all members present Resolution No. 993 was read  
207 for the third and final time and placed upon its passage.

208 Before the final vote all other interested persons were given an opportunity to be heard. Being  
209 no persons who wished to be heard, on roll call the Council voted: Eagan yes, Caputa yes, Schildroth  
210 yes, Henke absent, Pagano yes, Schmidt yes, Siam yes, Lee yes and Jones yes. Whereupon the Chair  
211 declared Resolution No. 993 to have been adopted.

212 Councilman Siam introduced Bill No. 9257 An Ordinance to authorize an amendment to B-5  
213 Ordinance No. 6868 to allow for a new sit-down, carry-out restaurant with signage for the property  
214 located at 2180 N Hwy. 67 and said Bill was read for the first time by title only.

215 Councilman Pagano introduced Bill No. 9258 An Ordinance amending the General Fund  
216 Budget to reflect \$85,000 from Asset Forfeiture Funds in escrow to Forfeiture Revenue Acct. 01-4-  
217 34511 and to the Forfeiture Expenditure Acct. 01-5-49-61000 for various police department  
218 expenditures and said Bill was read for the first time by title only.

219 Councilman Siam introduced Bill No. 9259 An Ordinance authorizing a Transfer of Special  
220 Use Permit 7716 from Tot Lots Learning Center to Florissant Kids Care Center, LLC for the operation  
221 of a day care located at 2184 N. Waterford Drive and said Bill was read for the first time by title only.

222 Councilmen Pagano and Caputa introduced Bill No. 9260 An Ordinance amending Title II,  
223 Chapter 205 by deleting Section 205.395 “Regulation of Pit Bull Dogs,” and said Bill was read for the  
224 first time by title only.

225 Councilmen Pagano and Caputa introduced Bill No. 9261 An Ordinance amending Title II  
226 Chapter 205 by amending Section 205.260 “Dangerous Animals,” and said Bill was read for the first  
227 time by title only.

228 Councilman Pagano introduced Bill No. 9262 An Ordinance amending Revenue Acct. No.  
229 3490 “Grants and Reimbursements” in the amount of \$9,780 and appropriating the sum of \$9,780  
230 from the General Revenue Fund to Budget Acct. No. 4921 “Uniforms” to purchase ballistic vests  
231 awarded through a local law enforcement block grant and said Bill was read for the first time by title  
232 only.

233 Councilman Pagano moved to move the Monday, February 27, 2017 City Council Meeting to  
234 Tuesday, February 28, 2017, seconded by Caputa. Motion carried.

235 The next item on the Agenda was Council Announcements.

236 Councilman Jones encouraged all residents to volunteer/donate to TEAM. He announced that  
237 the old Deaver’s Restaurant has changed ownership and has reopened as Irma Jean’s. Wednesday will  
238 be the grand opening. Steve Stenger, County Executive, had a cross walk installed across Charbonier  
239 Road at Park Side Estates, the newly completed subdivision. Mr. Stenger also helped install new  
240 signage in a timely manner to which Council and the administration was grateful.

241 Councilman Eagan announced that the St. Ferdinand March Madness is scheduled, starting with  
242 a BBQ on the last weekend in February. Officer Craig Tudor is the beneficiary of the fundraiser.

243 Councilman Caputa encouraged residents to secure their firearms and not leave them in their  
244 vehicles. The MSD work at Humes at Patterson Lane should be winding down soon. He thanked the  
245 Bully Alliance for their Valentines Gift.



246 Councilman Schildroth announced that on Feb. 2 he attended an MSD meeting regarding a  
247 project on Graham Rd which will last until approximately late spring.

248 Councilman Schmidt announced that “Right to Work” passed in Missouri and the labor unions  
249 are putting together a referendum. If enough signatures are collected and verified in a timely manner, it  
250 can be put to a vote of the people.

251 Councilman Pagano announced that Wards 5, 6, & 8 will be hosting a Neighbor Watch Meeting  
252 on March 7<sup>th</sup>.

253 The next item on the Agenda was Mayor Announcements.

254 Mayor Schneider announced that February 27<sup>th</sup> will be the Valley of Flowers Fundraiser Dinner  
255 at Hendel’s Restaurant. The Explorers Post will hold a trivia night at JFK on March 11<sup>th</sup>. The Mayor  
256 announced that there has been an overall decrease in crime within the City of Florissant. He thanked  
257 the Chief and the officers for their diligence in keeping Florissant safe. Jake Zimmerman, County  
258 Assessor, announced that property values were on the rise in Florissant. The Community  
259 Development Office will hold a public hearing for the CAPER on Tuesday February 28<sup>th</sup> at City Hall.  
260 All the mechanical upgrades at the Civic Center have been completed. The Mayor congratulated high  
261 school student Emily Bower on winning the “Poetry Out Loud Contest” who will represent the area in  
262 Washington D.C. on April 15<sup>th</sup>. St. Ferdinand Shrine recently had a very successful fundraiser at  
263 Kemoll’s Restaurant. The Parks and Recreation Department will host a spring break camp from 3/20  
264 thru 3/25 for ages 6-12. April 29<sup>th</sup> will be the City’s annual garage sale at the JJE ice rink and a free  
265 skate will be held on Feb 20. Feb. 28<sup>th</sup> is the dead line for the snowman building contest.

266 The next City Council Meeting is scheduled for Tuesday, February 28, 2017 at 7:30 pm.  
267 Councilman Caputa moved to adjourn the meeting, seconded by Jones. Motion carried. The meeting  
268 was adjourned at 9:03 p.m.

269

270

271

272

273 The following Bills were signed by the Mayor:

274 Bill No. 9255

Ord. 8295

275

---

Karen Goodwin, City Clerk

**CITY OF FLORISSANT  
CITY COUNCIL**

**OPEN EXECUTIVE SESSION**

February 13, 2017



The City Council of the City of Florissant met in open Executive Session on Monday, February 13, 2017 at 7:00 pm. in the Council Conference Room at the Florissant City Hall, 955 rue St. Francois, with Council President Jackie Pagano presiding. On Roll Call the following Council members were present: Caputa, Schildroth, Henke absent, Pagano, Schmidt, Siam, Lee, Jones and Eagan. Also present was Mayor Schneider, City Clerk Karen Goodwin and City Attorney John Hessel.

Councilman Lee moved to call for a closed meeting to confer with the City Attorney regarding litigation pursuant to Section 610.021(2) of the Revised Statutes of Missouri, seconded by Caputa. On Roll Call the Council voted: Jones yes, Eagan yes, Caputa yes, Schildroth yes, Henke absent, Pagano yes, Schmidt yes, Siam yes and Lee yes. Motion carried.

The Council conferred with the City Attorney regarding litigation.

Councilwoman Pagano moved to open the closed executive session, seconded by Eagan. On roll call the Council voted: Jones yes, Eagan yes, Caputa yes, Schildroth yes, Henke absent, Pagano yes, Schmidt yes, Siam yes, Lee yes. Motion carried.

There being no further business to discuss, Councilwoman Pagano motioned to adjourn, seconded by Jones. Motion carried and the meeting adjourned at 7:20 pm.

---

Karen Goodwin  
City Clerk



**CITY OF FLORISSANT  
CITY COUNCIL**



**WORKSHOP**

January 30, 2017

The City Council of the City of Florissant met in an open Work Session on Thursday, January 30, 2017 at 6:30 pm. in the Council Chambers at the Florissant City Hall, 955 rue St. Francois, with Council President Jackie Pagano presiding. On Roll Call the following Council members were present: Caputa, Schildroth, Henke, Pagano, Schmidt(absent), Siam, Lee, Joes, Eagan. Also present was Mayor Schneider and City Clerk Karen Goodwin and City and Finance Director Randy McDaniel.

The Chair called on Lou Jearls first to discuss public works issues.

Court Building update:

Lou Jearls reviewed the schedule for the bid process and construction projections. Advertising through the notice to proceed for this project will take a couple of months. There will be a mandatory pre-bid walk through and a second opportunity to walk through the facility. Three contracts will be awarded because of the size of the project. Mechanical and electrical will be separate bids.

Councilwoman Pagano asked if there would be any incentives for early completion. Mr. Jearls said no, just penalties if the project is delayed. He said that some delays will be allowed if it is not in control of the contractor such as weather.

Councilman Caputa asked if the roof of the building needs to be replaced. Lou Jearls said the roof needs work but cannot be done until the construction begins because equipment is being moved around on the roof.

Councilman Lee asked about the expected construction time allowance. Mr. Jearls said that they think that 9 months is a reasonable amount of time. Councilman Lee asked if there is an opportunity to open the court portion before the entire project is finished. Mr. Jearls stated that may be possible.

Councilwoman Pagano asked the Mayor if letters have been sent to other cities letting them know that the facility would be available for use. Mayor Schneider stated that he has communicated with some other municipalities.

Councilman Jones stated that he saw that St. Ann was taking some other municipalities on. He asked about the air conditioning unit that was on the roof, is there anything that can be reused? Mr. Jearls stated that the equipment could not be used because of the different configuration.

Mayor stated that the council needs to determine what the building will be called.

#### Trash receptacles at Bus Stops:

Mr. Jearls stated that there are currently 7 bus stops that have trash cans. They are looking to add wherever they are needed. Let him know if there are additional spots that are needed. Councilman Jones asked if the cans are secured. Mr. Jearls answered yes but they still get stolen.

Councilman Eagan asked how many citations are given for littering. He asked that littering be made a priority.

Councilman Henke would like to see a litter awareness campaign. Community service messages through signs, newspaper; a city wide effort. Councilwoman Pagano stated that she mentioned this before and would like to involve the school districts.

Council discussed trash issues in the city.

Councilwoman Pagano proposed having the next workshop in April. The plan should be to review and discuss by department.

#### Review selected revenue sources:

Randy McDaniel reviewed revenue sources as depicted in the handout he gave to the council.

Councilman Henke requested an executive session on specific revenue matters.

Councilman Henke stated that the state will start collecting sales taxes from Amazon. He stated that he knows we need to have a general use tax to be able to collect it. Mayor Schneider stated that he is suggesting that the cities do it all at the same time. He stated that if the city has a use tax we would only benefit from the local taxes not the pool tax. Mayor is working on a plan to be able to benefit from this change. Councilman Caputa stated that the MML is working on helping all of the municipalities to take advantage of the taxes.

Councilwoman Pagano stated that she feels they need to get the contractor for the grass and weeds and get ahead of the game. Councilman Jones stated that he has called some of the other municipalities to see how long the limit is in other cities. He said that the city staff should be cutting the city property and the private property should be cut by contractors. Councilman Henke stated that the staff needs to understand that this effort is not to replace city employees but to assist when the workload is too much.

#### Public Works Fees:

Mr. McDaniel reviewed the list of public works fees handed out to the council.

Councilwoman Pagano gave a brief update on the classes that are being offered in the Crime Free program. She said there has been a lot of good news and positive feedback.

Mr. McDaniel reviewed the 2017 Budget discussing the General Fund revenues and expenditure budget. He also discussed personnel and benefits.

St. Louis County Public Safety sales tax on the April ballot. The city will see some of the funds 6 months or so after it passes if it passes.

Mr. McDaniel discussed some questions that have been asked about early retirement incentives. Council discussed the retirement plans.

Mr. McDaniel discussed the bond rating the bid results and the appropriation for the 2017 debt payments. He explained the credit ratings and the bond sale.

Mr. McDaniel discussed the use tax rates in St. Louis County. He presented a list of the use tax in other municipalities. Council discussed the issue on the ballot and the approach to the residents.

Councilman Lee stated that he is thinking ahead to the 2020 census. He is concerned about what will happen after the census. Mr. McDaniel agreed that the city needs to be paying attention.

#### Citizens Comments:

Mr. Engelmeyer asked about soliciting bids from minorities. He also asked about the pre-bid meeting location. He is also concerned about the trash containers at the bus stops. Pension plan is falling short and needs to be addressed. He said that the city needs to decrease spending or raise revenue.

Ben Hammond asked about the Grass cutting contract, is it an annual contract? Councilman Lee explained the process.

Kevin O'Donnell stated that White Castle has no outside trash receptacle? Commercial properties should be required to have trash receptacles on their parking lots as a part of their construction plans.

There being no further business to discuss, Councilman Jones motioned to adjourn, seconded by Pagano. Motion carried and the meeting adjourned at 7:56 pm.

---

Karen Goodwin  
City Clerk

**Karen Goodwin**

---

**From:** Niki Leingang <niki\_leingang@yahoo.com>  
**Sent:** Monday, February 13, 2017 6:46 PM  
**To:** Karen Goodwin  
**Subject:** Repeal ban on pit bull breeds

Dear Councilmembers,

I would like to request repeal of the ban on pit bull breeds by the city of Florissant. Please focus on the breed neutral aggressive dog ordinance. Thank you!

For Council and for Inclusion in Communications Portion of the February 13th Agenda.

Niki Featherly  
3032 Apple Blossom Ct  
High Ridge 63049

Sent from Yahoo Mail for iPhone

**Karen Goodwin**

---

**From:** Sandra L. <sandralink42@gmail.com>  
**Sent:** Monday, February 13, 2017 9:09 PM  
**To:** Karen Goodwin  
**Subject:** To the city council as a whole.

I am writing to you once again, to state to you that as a current constituent and resident of Florissant, I want the breed specific legislation, particularly that specific to Pitbulls, repealed.

The aggressive dog legislation on the books is more than sufficient to keep our residents **safe from dogs whom are actually dangerous** when appropriately implemented.

I, as well as many other residents of both Florissant and St. Louis county, **do NOT support this ban.**

Stop wasting our city's and county's resources on this unsuccessful and **illegal ban.**

Do include my email regarding the ban on the next city council agenda. I want this email to be read by and to the council members as I am unable to attend this meeting.

Sandra Link 685 Madison Ln. Florissant Mo. 63031

**Karen Goodwin**

---

**From:** STEPHANIE CAWVEY <smcawvey1@sbcglobal.net>  
**Sent:** Tuesday, February 14, 2017 7:20 AM  
**To:** Karen Goodwin  
**Subject:** Subject: regarding the repeal of the pit bull ban

Dear Councilmembers,

I would like to request repeal of the ban on pit bull breeds by the city of Florissant. Please focus on the breed neutral aggressive dog ordinance. Thank you!

For Council and for Inclusion in Communications Portion of the February 28, 2017 Agenda.

Mike and Stephanie Cawvey  
835 Loyola  
Florissant MO 63031

Sent from Yahoo Mail on Android



**Karen Goodwin**

---

**From:** Thelma Schaefer <tjschaefer@prodigy.net>  
**Sent:** Tuesday, February 14, 2017 7:48 AM  
**To:** Karen Goodwin  
**Subject:** Regarding the repeal of the pit bull ban

Dear Councilmembers,

I would like to request repeal of the ban on pit bull breeds by the city of Florissant. Please focus on the breed neutral aggressive dog ordinance. Thank you!

For Council and for Inclusion in Communications Portion of the February 28, 2017 Agenda.

Thelma Jean Schaefer  
1944 Night Drive  
Florissant, MO 63031

**Karen Goodwin**

---

**From:** dan johnson <djblues11@outlook.com>  
**Sent:** Tuesday, February 14, 2017 8:05 AM  
**To:** Karen Goodwin  
**Subject:** Regarding the repeal of the pit-bull ban

Dear Councilmembers,

I would like to request repeal of the ban on pit bull breeds by the city of Florissant. Please focus on the breed neutral aggressive dog ordinance. Thank you!

For Council and for Inclusion in Communications Portion of the February 28, 2017 Agenda.

Daniel Johnson  
2525 Valley Brook Dr.  
Florissant, MO 63031

**Karen Goodwin**

---

**From:** Jenny Truax <cwjedi@gmail.com>  
**Sent:** Monday, February 13, 2017 2:01 PM  
**To:** Karen Goodwin  
**Subject:** Please add to City Council Meeting Agenda

Dear Members of the City Council,

Please repeal the ban on Pit Bulls. We know that Breed Specific Laws have proven to be ineffective at reducing violence, and are a massive waste of taxpayer money.

Over and over, we've seen BSL's fail to reduce dog bites. We need rational solutions that target negligent dog owners, not whole breeds of dogs.

Thank you.

Jenny Truax  
1875 Madison St.  
St. Louis, MO 63106

**Karen Goodwin**

---

**From:** Jim & Kim <theorphans1@sbcglobal.net>  
**Sent:** Monday, February 13, 2017 10:34 AM  
**To:** Karen Goodwin  
**Subject:** Re: Bully Ban

Sure,  
1964 Graystone Drive, St Charles, MO 63303

Thanks!

On Monday, February 13, 2017 9:16 AM, Karen Goodwin <[kgoodwin@florissantmo.com](mailto:kgoodwin@florissantmo.com)> wrote:

Hello Kim, please include your address for the record so I can include it on the agenda.

Sincerely,  
Karen

-----Original Message-----

**From:** Kim Orf [mailto:[theorphans1@sbcglobal.net](mailto:theorphans1@sbcglobal.net)]  
**Sent:** Friday, February 10, 2017 7:02 PM  
**To:** Karen Goodwin  
**Subject:** Bully Ban

I am a past resident for 40 years. Please tell the council to repeal the bully ban.  
Thank you!  
Kim Orf

Sent from my iPhone

## Karen Goodwin

---

**From:** Mindy Rouff <mmrouff@gmail.com>  
**Sent:** Sunday, February 12, 2017 10:22 PM  
**To:** Karen Goodwin  
**Subject:** Stop BSL! Please add my letter to your meeting agenda  
**Attachments:** Letter to Florissant City Council regarding BSL.docx

Dear Members of the City Council:

Re: Repeal your breed ban! Please add my email to the meeting agenda.

I grew up in Florissant, and I was horrified to learn that the City of Florissant has killed 201 innocent dogs since it enacted Breed Specific Legislation in 2010, and I beg you to repeal your Breed Specific Legislation (*RFT*, "For the Dogs"). I know BSL is wrong, and I know it in both my head and my heart. I know it is wrong from a practical standpoint because no major animal welfare group thinks BSL is the way to stop dog bites. In fact, leading groups argue against BSL. And, I know it is wrong from life experience. I have seen many a pit mix come into Stray Rescue, where I volunteer, and although they have been endured nothing but suffering and neglect at human hands, they seek out human love and affection.

It is the height of cruelty to kill dogs who have never bitten any human or any other animal. There is no such thing as a vicious breed of dog, another thing you'd learn if you created laws based on what experts on animal behavior have to say. There are vicious owners who mistreat their dogs, but these people aren't going to be deterred by BSL. When you enacted your BSL, did you really think people who fight dogs would say, well, pit bulls aren't legal here in Florissant so no dog fighting here?! People who fight dogs don't care about your city ordinances. I suspect you know this and that, instead, there were racist, classist reasons for enacting BSL, and honestly, this makes me just as sad as knowing you are killing dogs for no reason.

Your BSL has a terrible impact on families, especially families who don't have the money to pay for a DNA test (also DNA tests are often inconclusive so they wouldn't even help every dog owner) or who don't have the resources/time to find a new home for their pet. You should be ashamed every time you think of dogs being taken from loving families and then killed. Imagine what that does to children in those families? Did you never have a beloved childhood pet? How would you have felt if one day someone came to your house, gave you a tiny window to find it a new home, and then killed it when you couldn't? You don't need to be a child to be traumatized by Florissant's behavior. It sickens me. Rather than stopping neglectful owners or dog-fighters from moving to Florissant, you have kept good people from moving into Florissant or forced good people to move out. I, for one, based my home search on which cities did NOT have breed bans. I will never willingly live in a city with BSL on principle (because BSL is wrong) and because I don't want anyone to tell me what dogs I can and can't adopt. I want to find the best fit for my family---whatever the breed or mix may be. Of course, many people don't have the luxury of living in whichever city they want. Some people have to live in BSL cities and you are infringing upon their rights.

You are also making life more difficult for our local shelters or rescues. It breaks my heart thinking about all the potential adopters that aren't even possible contenders due to BSL where they live. I was once a foster parent for Stray Rescue and I know how hard it can be to get dogs adopted. I have actually heard people say, I'd love to adopt this dog, but I can't because it looks like a pit bull and I live in Florissant.

I care about this issue very much. Only a trip to KC kept me from attending the meeting in person. Please do the right thing and repeal your BSL.

Sincerely,

Mindy Rouff, 3726 Hartford St., St. Louis, Mo 63116

## **Karen Goodwin**

---

**From:** Matt Beeman <vuchnich@gmail.com>  
**Sent:** Sunday, February 12, 2017 10:02 PM  
**To:** Karen Goodwin  
**Subject:** End BSL

Members of the City Council -

Please add my email to the meeting agenda

As a dog lover, and an owner of a (very friendly) pitbull mix, I am writing to ask your consideration to stop BSL. The data shows that it is a misguided safety measure, and the only thing it does is stigmatize certain breeds and make their and their owners' lives harder. People should not have to choose between living somewhere or keeping their dog. Sometimes the dog loses that decision and will wind up on the street. Or sometimes the dog will not be adopted because someone can't keep that breed in their city. Sometimes people have to move when they don't want to or can ill afford to.

ALL dogs can bite - the issue is with owners and training, not with breeds. If anything, the laws should speak to owner behavior, not dog breed.

I understand the thinking behind BSL, and the impulse to try to keep people safe, but these laws are grounded in faulty thinking - and should be left behind us.

Thanks, and thanks for your consideration

Matt Beeman  
3726 Hartford St  
St. Louis MO 63116  
[vuchnich@gmail.com](mailto:vuchnich@gmail.com)

**Karen Goodwin**

---

**From:** Lacey K. <laceywebbie@hotmail.com>  
**Sent:** Saturday, February 11, 2017 2:59 AM  
**To:** Karen Goodwin  
**Subject:** City Council meeting agenda BSL

Good evening,

This email is to the city Council as a whole and please include it on the next City Council meeting agenda.

My name is Lacey Knox and my address is 805 Brookmead Dr. O'Fallon MO 63366.

I would like to respectfully ask that you all consider repealing the breed specific legislation and anti-pitbull bans that are in place within the city of Florissant.

Thank you for your time and please let me know if you have any questions or concerns.

Kind regards,  
Lacey Knox



**Karen Goodwin**

---

**From:** nutterbutter88@gmail.com on behalf of Theresa Schmidt <schmidtmarie@gmail.com>  
**Sent:** Friday, February 10, 2017 8:40 PM  
**To:** Karen Goodwin  
**Subject:** For the love of the dogs: Please repeal the pit bull ban!!

To Whom It May Concern:

As the proud parent of a lovable, snuggable dog that many would probably call a "pit bull", I would like to request repeal of the ban on pit bull breeds by the city of Florissant.

Just as you do, I wish to ensure that the neighboring community of Florissant is a safe community. However, BSL is not an effective method of creating a safe community; in fact BSL has never been proven to reduce dog bites. The list of animal experts and authorities opposed to breed-specific legislation is extensive and includes the American Veterinary Society of Animal Behavior, the American Bar Association, the American Kennel Club and even the US Department of Justice.

I encourage you to visit the Animal Farm Foundation's website with a [collection of facts and statements regarding breed specific legislation.](#)

Ultimately, I think you will agree with the experts and the many citizens of Florissant who have spoken in support of repealing this ban that doing so is the right thing to do economically, legally and morally.

For Council and for Inclusion in Communications Portion of the February 13th Agenda.

Theresa Schmidt  
10344 Sannois Dr., Apt. 4  
Creve Coeur, MO 63146-5946

Thank you for your consideration of this e-mail, and this issue.  
Sincerely,  
Theresa

***Theresa Schmidt***  
*Development Associate at the Central Institute for the Deaf*  
*Cell: 618-402-7466*  
*Work: 314-977-0220*  
[schmidtmarie@gmail.com](mailto:schmidtmarie@gmail.com)

**Karen Goodwin**

---

**From:** Christie Lenox <christie.lenox@gmail.com>  
**Sent:** Friday, February 10, 2017 7:06 PM  
**To:** Karen Goodwin  
**Subject:** Repeal of Pit Bull Breeds

Dear Councilmembers,

I would like to request repeal of the ban on pit bull breeds by the city of Florissant. Please focus on the breed neutral aggressive dog ordinance. Thank you!

For Council and for Inclusion in Communications Portion of the February 13th Agenda.

Christie Lenox  
507 N. 13th Street, #705  
St. Louis, MO 63103

## Karen Goodwin

---

**From:** Michelle Stokes <michelle@slemspetcare.com>  
**Sent:** Friday, February 10, 2017 6:45 PM  
**To:** Karen Goodwin  
**Subject:** Stop BSL

Dear Members of the City Council,

I'm sending this e-mail to request you please repeal the ban on pit bills in the city of Florissant MO. I too incorrectly believed at one time the hype that pit bulls are dangerous animals. Then, after volunteering at an animal shelter, I learned very quickly how wrong I was. I have volunteered now for several years and not one time have I been attacked or even snapped at by a pit bull. I have been bitten by other breed and by cats, but never a pit bull. And after seeing several pit bulls go to their forever homes, I learned they make wonderful pets. So please, stop BSL. And if you can't do that, then consider volunteering at an animal shelter and see for your self what wonderful animals pit bull terriers really are.

Sincerely,  
Michelle Stokes  
2008 Wismer Ave  
Overland MO, 63114

sent from my iPhone

**Karen Goodwin**

---

**From:** Stefanie Slemmer <skslemmer\_09@yahoo.com>  
**Sent:** Friday, February 10, 2017 4:57 PM  
**To:** Karen Goodwin  
**Subject:** repeal BSL

Dear Members of the City Council,

I would like to see the Pit Bull ban repealed. I do not agree with my tax dollar being spent to euthanize dogs from your city.  
Please include my email in your meeting agenda.

Thank you,  
Stefanie Skaggs

2612 Poe Ave  
St. Louis, MO  
63114

**Karen Goodwin**

---

**From:** Alma Slemmer <grannyslem@gmail.com>  
**Sent:** Friday, February 10, 2017 4:50 PM  
**To:** Karen Goodwin  
**Subject:** Repeal BSL

Dear Council Members,

Please consider repealing the pit bull ban. You should know by now it is a waste of time and tax payers money. Please add my email to the meeting agenda.

Thank you,  
Alma Slemmer  
2612 Poe Ave  
St. Louis, Mo  
63114

## **Karen Goodwin**

---

**From:** Craig Schoeller <craigsc2009@live.com>  
**Sent:** Tuesday, February 14, 2017 9:09 PM  
**To:** Karen Goodwin  
**Subject:** repeal the ban on pit bulls

Greetings All Florissant Board Members,

Please repeal all "Breed Specific Legislation". I know you think the quick fix is to outlaw the breed. That is not going to help anyone. As I know you are already aware that many residence in your city still own bully breeds. What would you feel like if your city were to become the model city for bully breed tolerant? If you look at all dog bite reports, you will see a common thread. We as humans are at fault. We either abuse or are ignorant about the personality and traits of the breed of the animals we adopt or rescue. On the abuse side, we know what the breed is capable of doing and use it most of the time for illegal purposes. (Defend the home of a drug dealer or someone involved in this or another illegal activity) or treat the dog badly. As for the ignorant side, we think it is either cool or pit bull puppies look really cute, but the humane usually knows nothing about the breed. A possible solution would first be that all pet owners register their dog with the city. You would also still provide proof of Rabies vaccination if you do not already do so. Other communities do this by charging 2 dollars for a tag each year. The bully breed owners could require owners to provide a photo of the animal too. In addition, bully breed owners could be required to take a class to educate them on what these breeds and other dogs can also do if not properly trained and raised. The class could also include how to introduce strangers, other dogs and children to dogs in general. The cost of these classes would have to be reasonable though. Could also put in place a substantial fine for not following these guidelines. These reasonable requirements would be income for the city. May also be able to work with local businesses or individuals that train animals for discounts for your residence. A \$1,000,000 homeowners or renters insurance policy medical rider would be required and a beware of dog signs on your fence. One other question. Would you tell the owners of Spuds Makenzie or Target dog that they could not move to your city unless they got rid of their dog. If you would say no, you are a hypocrite. Both of those dogs are Bull Terriers, the main breed in a pit-bull. All these minimal requirement's will help weed out the individuals that should not have a dog, Lessen the burden on local shelters and give more dogs a warm and loving forever home.

Thank you for taking time out to read and consider the suggestions in this e-mail and please add it to the next meeting agenda. I respectfully request a reply verifying that my email has been received and will be included on the agenda.

Thank you

Craig Schoeller

1442 Attica

Bellefontaine Neighbors MO 63137

**Karen Goodwin**

---

**From:** Rhiannon Fryer <rhiannon7593@gmail.com>  
**Sent:** Wednesday, February 15, 2017 9:37 AM  
**To:** Karen Goodwin  
**Subject:** Regarding the repeal of the pit bull ban

Dear Councilmembers,

I would like to request repeal of the ban on pit bull breeds by the city of Florissant. Please focus on the breed neutral aggressive dog ordinance. Thank you!

For Council and for Inclusion in the Communications Portion of the February 28, 2017 Agenda.

Rhiannon Fryer  
1145 Boone Street  
Florissant MO 63031

**Karen Goodwin**

---

**From:** John Roth <jroth42@gmail.com>  
**Sent:** Tuesday, February 14, 2017 11:47 AM  
**To:** Karen Goodwin  
**Subject:** Pit bull ban

To the city council as a whole.

I would like the pit bull ban repealed. There is absolutely no need for it. If we want a city residents can feel pride in, then we need to not have laws on the books just for the sake of ignorance. Thank you.

Sincerely,

John Roth  
685 Madison Ln  
Florissant, MO 63031

Please include my email on the next city council meeting agenda. I'd like a reply verifying that my email has been received and will be included on the agenda. Thank you



## Karen Goodwin

---

**From:** Terry Hoppes <tberry73@icloud.com>  
**Sent:** Tuesday, February 21, 2017 8:33 AM  
**To:** Karen Goodwin  
**Subject:** Pitbull ban ordinance

Good Morning Karen....I am writing you in earnest to support keeping the Pitbull ban ordinance as it stands in our fair city of Florissant....I have witnessed this aggressive breed of dogs first hand....A few years ago, a 5 year old was attacked in our neighborhood....The owners continued to argue that their dog would not do this as it was witnessed by several....I am a dog lover & as I walk my dog around the block, I see how excited most dogs inside or in their fence act... Always praying that they don't jump that fence....I feel that folks that have a love of this breed of dog can live in the unincorporated areas that allow them or find another breed of dog....As we all know, they are trained to be aggressive....For security, etc....A proven fact that this is in their nature....Thank you for letting me express my feelings on this matter.

Sincerely, Terry Hoppes-Hulcer  
1635 Gallant Fox Drive  
[Tberry73@charter.net](mailto:Tberry73@charter.net)

Sent from my iPhone

**Karen Goodwin**

---

**From:** Best Friends Animal Society <Legislative@bestfriends.org> on behalf of Mary Wacker <info@bestfriends.org>  
**Sent:** Monday, February 20, 2017 9:30 PM  
**To:** Karen Goodwin  
**Subject:** Save tax dollars and pets: Repeal the breed discriminatory law

Feb 20, 2017

City Clerk Karen Goodwin  
Florissant, MO

Dear City Clerk Goodwin,

We all want safe and humane communities. As a Florissant resident, I ask that you repeal the breed-discriminatory ordinance targeting alleged "pit bull" terriers. The old ordinance is not only ineffective, but it is expensive to enforce and violates the property rights of responsible pet owners.

The city council should listen to its caring residents who attend city council meetings each month and act to repeal the ban. The city needs to move onto other important matters. Wentzville, Town & Country, Clayton and Manchester -- like numerous Missouri cities -- have all repealed "pit bull" laws. Florissant should follow their lead.

It is clear that breed discrimination goes against the tenets of community policing. How can people trust government officials if their well-behaved pets are seized for no reason? Do we really want to be known as a community that makes citizens get rid of their innocent pet dogs? The focus of any dangerous dog law should be on the behavior of the owner and the behavior of the dog.

Florissant should not embrace the discriminatory policies of Ferguson that include an ordinance targeting pit bull terriers. Our community is better than that. We should prohibit reckless owners from owning pets (as the city of Skokie, Illinois, has done), rather than penalize responsible pet owners for the alleged breed of their dogs.

In America, responsible dog owners who follow safety rules should be able to own whatever breed of dog they choose. It's that simple.

Thank you for your efforts to repeal the breed discriminatory law and make Florissant a community where people with pets want to live.

Sincerely,

Ms. Mary Wacker  
511 River Forest Dr  
Wentzville, MO 63385-4742  
(314) 749-7336  
[mtwacker@gmail.com](mailto:mtwacker@gmail.com)

## Karen Goodwin

---

**From:** stlcount <stlcount@aol.com>  
**Sent:** Monday, February 20, 2017 8:39 PM  
**To:** Karen Goodwin  
**Subject:** FOR the pit bull ban

Dear Council members,

While all dogs can be mean and some people owners are idiots I don't want a pit bull or any other dangerous dog near me.

Every year dozens of innocent infants and children are killed by pit bulls and people seriously injured through unprovoked attacked. These are vicious animals that were intentionally bred through artificial selective breeding programs to "kill" in a "pit." Hence the name "pit bull." There is no civilized reason why they should have ever been selectively bred in the first place, they are nothing but vicious "killing machines,"

For Council and for Inclusion in Communications Portion of the February 28, 2017 Agenda.

David Counts  
Letha Counts  
1070 st.denis  
Florissant Mo 63031

**Karen Goodwin**

---

**From:** Samantha Scarfino <sscarfino89@gmail.com>  
**Sent:** Monday, February 20, 2017 3:02 PM  
**To:** Karen Goodwin  
**Subject:** BSL

To the city council as a whole,

I would like to see the City of Florissant, which I live in, repeal the Breed Specific Legislation against Pit Bulls. It is unfair and unjust for a breed to be discriminated against when we all know it is the irresponsible dog owners that produce vicious dogs, not a specific breed.

Please include my email on the next city council meeting agenda. I would like a reply verifying that my email has been received and will be included on the agenda. Thank you.

Samantha Scarfino  
1700 St. Francois St.  
Florissant, MO 63033

## Karen Goodwin

---

**From:** Best Friends Animal Society <Legislative@bestfriends.org> on behalf of Marilyn Mayfield <info@bestfriends.org>  
**Sent:** Monday, February 20, 2017 12:29 PM  
**To:** Karen Goodwin  
**Subject:** Save tax dollars and pets: Repeal the breed discriminatory law

Feb 20, 2017

City Clerk Karen Goodwin  
Florissant, MO

Dear City Clerk Goodwin,

We all want safe and humane communities. As a Florissant resident, I ask that you repeal the breed-discriminatory ordinance targeting alleged "pit bull" terriers. The old ordinance is not only ineffective, but it is expensive to enforce and violates the property rights of responsible pet owners.

The city council should listen to its caring residents who attend city council meetings each month and act to repeal the ban. The city needs to move onto other important matters. Wentzville, Town & Country, Clayton and Manchester -- like numerous Missouri cities -- have all repealed "pit bull" laws. Florissant should follow their lead.

It is clear that breed discrimination goes against the tenets of community policing. How can people trust government officials if their well-behaved pets are seized for no reason? Do we really want to be known as a community that makes citizens get rid of their innocent pet dogs? The focus of any dangerous dog law should be on the behavior of the owner and the behavior of the dog.

Florissant should not embrace the discriminatory policies of Ferguson that include an ordinance targeting pit bull terriers. Our community is better than that. We should prohibit reckless owners from owning pets (as the city of Skokie, Illinois, has done), rather than penalize responsible pet owners for the alleged breed of their dogs.

In America, responsible dog owners who follow safety rules should be able to own whatever breed of dog they choose. It's that simple.

Thank you for your efforts to repeal the breed discriminatory law and make Florissant a community where people with pets want to live.

Sincerely,

Mrs. Marilyn Mayfield  
101 Stoneleigh Towers  
Olivette, MO 63132-3716  
(314) 993-9012  
[mytmay@sbcglobal.net](mailto:mytmay@sbcglobal.net)

**Karen Goodwin**

---

**From:** Amber Fox <amberlydiafox@gmail.com>  
**Sent:** Monday, February 20, 2017 10:20 AM  
**To:** Karen Goodwin  
**Subject:** regarding the repeal of the pit bull ban

Dear Councilmembers,

I would like to request repeal of the ban on pit bull breeds by the city of Florissant. Please focus on the breed neutral aggressive dog ordinance. Thank you!

For Council and for Inclusion in Communications Portion of the February 28, 2017 Agenda.

Amber Fox  
279 Elmdale Ct.  
Florissant, MO 63031

## Karen Goodwin

---

**From:** Cindi O'Shea <cindioshea@yahoo.com>  
**Sent:** Monday, February 20, 2017 8:48 AM  
**To:** Karen Goodwin  
**Subject:** To the Council as a Whole / Support of Current Ban on Pit Bulls  
**Attachments:** Cindi O'Shea Florissant Pit Bull Ban.docx

Good Morning Ms. Goodwin.

I respectfully request that the attached document be included on the agenda for the next Council meeting, held on February 28, 2017. I would like a reply verifying that my email has been received and will be included on the agenda.

It is my understanding, after speaking to a Council Member, I may be able to address the Council after the third reading of the repeal bill and I will not be subject to a time limit.

I look forward to your reply as well as speaking to the Mayor and Council members at the meeting on February 28, 2017.

Sincerely,

Cindi O'Shea  
125 W. St. Anthony Lane  
Florissant, MO 63031  
423.315.7538

February 17, 2017  
The Honorable Mayor Thomas P. Schneider  
Councilman Tim Lee  
Councilman Joseph Egan  
Councilman Jeff Caputo  
Councilman Keith Schildroth  
Councilman Gerard Henke  
Councilwoman Jacki Pagano  
Councilman Mark Schmidt  
Councilman Tommy Siam  
City Attorney John Hessel

Good Afternoon,

I attended the recent City Council meeting after seeing a news report about the possible repeal of Section 205.393 Regulation of Pit Bull Dogs. Having just recently relocated back to Florissant after 20 years, I admit I am not fully apprised of what is going on in Florissant. I spoke in favor of not only keeping the current section of the Ordinance, but urged the Mayor and Council to study similar ordinances in other cities in the United States and Canada. In particular, Aurora Colorado has an outstanding ordinance. It's also important to note that Aurora *requires* all dogs and cats to be spayed/neutered. Both Section 205.260 and 205.395 are in need of revision to expand the language to protect our citizens.

While Aurora is a city with over 350,000 residents, Florissant can be proactive and look to future growth of pet ownership and enact laws to prevent issues such as this one, instead of using a Band-Aid approach. As I commented at the meeting, I am strongly urging you to research medical findings, such as those stated in: *Characteristics of 1616 Consecutive Dog Bit Injuries at a Single Institution*.  
<https://www.ncbi.nlm.nih.gov/pubmed/27400935>

We must look beyond the emotional statements, pictures and non-factual information you have received by owners, shelters and other organizations that continue to turn a blind eye to the facts. The human populace is to blame for what the Pit Bull and Pit Bull Mixed Breed dog has become. Uncontrolled breeding, inbreeding, poor socialization, unlawful fighting and pure greed have forever changed this breed in the majority of our towns and cities in the United States. I have experienced firsthand the issues with the population of these dogs in other cities I have lived in. Please take some time to read the Ordinances in place in the City of Aurora, Colorado.

This a prime opportunity for the City of Florissant to proactively enact laws and measures to protect the citizens and visitors. Before attending this last meeting, I spent the day researching *facts* about the medical implications of dog bites/maulings/fatalities by this breed. I was shaken to my core reading the specifics regarding the many deaths caused by the breed throughout the United States and Canada.

Several factual snippets are inserted in this document but *please do additional research and read the facts*.



I urge all of you to not let the BSL Group and their large numbers at the Council Meetings sway you from examining the pertinent facts surrounding this issue.

I am asking that this issue be continued and that no vote be taken at the next Council Meeting so that you all have ample opportunity to digest the facts. Below are my comments from the past meeting and snapshots of facts I obtained during my research.

Thank you all so very much for your time and attention to this important and urgent issue. I am most happy to research facts, as a citizen of Florissant, and present them to you as we go forward.

Finally, should this ban on Pit Bulls be repealed, I will most certainly move from the city I grew up in, and am now happily relocated back to. Keep Florissant safe from this breed and the associated crime that unfortunately goes hand in hand with the breed.

From the February 13, 2017 Council Meeting:

Good Evening. My name is Cindi O'Shea. Thank you for allowing me to speak. I have relocated back to my hometown of Florissant after 20 years and until last night, wasn't aware of the issue regarding Pit Bull and similar dog breeds. I will preface my remarks with the fact that my background as a vet tech since 2012 may show another perspective/opinion about this topic. I lived in Parker, Colorado and worked at Banfield Pet Hospital in Aurora, Colorado, Parker, Colorado and Hixson, Tennessee. I most recently worked for Northgate Animal Hospital in Hixson, Tennessee. While I do not know the nature of the many emails submitted either for or against the issue, I want to point out that both sides should review/research factual findings with regard to the Pit Bull and mixed-breeds containing American Staffordshire Terrier, Staffordshire Bull Terrier and American Bulldog. DNA testing is the genetic blueprint that contains most of the genetic instructions for every canine's body make up (height, weight, size, etc.) DNA testing is a genetic analysis to identify key genetic markers that may detect the breed, type and variety of a dog and may show the ancestral breed composition of a particular dog. I recommend a blood sample DNA test, obtained from a veterinarian, versus an over-the-counter saliva swab, as the blood sample can accurately trace back several generations of breeds.

Having worked in Aurora, Colorado as a vet tech, I am well-versed in the deception many Pit Bull and Pit Bull Mix Breed owners will go to falsify the breed of their dogs. Aurora not only has a ban on Pit Bulls, but it also requires all dog and cat owners to spay/neuter their pets. (Note highlighted text, above) From my experience in the veterinary field, with regard to the Pit Bull and Pit Bull Mixed Breeds, it is not a question of IF there will be a bite/attack, but WHEN. This statement has been made by every DVM I have worked for. I have experienced it firsthand, utilizing every available correct interaction with the pet, correct restraint, client education, etc. My first unfortunate experience happened when I was simply walking down a hallway and passed a client with her female Pit Bull. I did not make any eye contact with either, was walking calmly, with a file in one hand. Without warning, the dog attempted to bite my free hand that was at my side. On subsequent visits, despite consistent education with the owner, the dog became increasingly aggressive, to the point that she had to be muzzled by the owner, prior to entering the exam room. This is just ONE of MANY examples. I carry permanent scars from a

client's Pit Bull that had been the sweetest pet on multiple visits over a year. Great disposition! Out of nowhere, with the owner present, I was mauled.

People on BOTH sides of this debate are strongly urged to read factual, medical studies from Trauma Centers throughout the U.S. The conclusions are staggering. I've had the opportunity to read nearly all of the emails sent in by residents who want Section 205.395 repealed. I urge the Council to research the dozens of factual, **not emotional** medical studies/articles as well as factual information from various cities in the U.S. and Canada with stringent laws on the books banning the Pit Bull and mixed-Pit Bull breeds before making any decision to repeal this law.

### Dog Attacks from 1982 to 2015

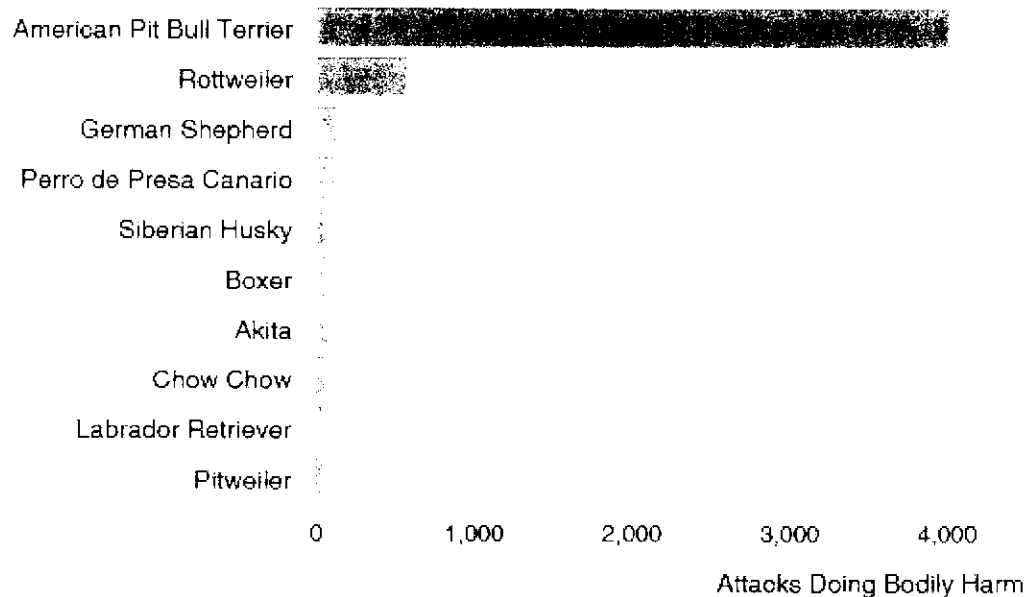

Source: Animals 24-7. As of December 31, 2015; refreshed Annually. [Show details](#)

[See more details](#)



[PetBreeds | Graphiq](#)

## 2015 dog bite fatality statistics

- 34 U.S. dog bite-related fatalities occurred in 2015. Despite being regulated in Military Housing areas and over 700 U.S. cities, pit bulls contributed to 82% (28) of these deaths. Pit bulls make up about 6.6% of the total U.S. dog population.<sup>2</sup>
- Together, pit bulls (28) and rottweilers (3), the second most lethal dog breed, accounted for 91% of the total recorded deaths in 2015. This same combination also accounted for 76% of all fatal attacks during the 11-year period of 2005 to 2015.
- The breakdown between these two breeds is substantial over this 11-year period. From 2005 to 2015, pit bulls killed 232 Americans, about one citizen every 17 days, versus rottweilers, which killed 41, about one citizen every 98 days.
- In the year of 2015, the combination of pit bulls (28), their close cousins, American bulldogs (2), and rottweilers (3) contributed to 97% (33) of all dog bite-related fatalities. Both American bulldog fatalities occurred in Miami-Dade County, Florida.
- Annual data from 2015 shows that 41% (14) of the fatality victims were children ages 9-years and younger, and 59% (20) were adults, ages 22-years and older. Of the total adults killed by canines in 2015, 65% (13) were ages 60-years and older.
- Annual data shows that when combining all age groups, male victims (20) were greater in number than female victims (14). Amongst children ages 9-years and younger, males were excessively victims 79% (11), versus females 21% (3).
- In 2015, nearly one third, 32% (11), of all dog bite fatality victims were either visiting or living temporarily with the dog's owner when the fatal attack occurred. Children ages 9-years and younger accounted for 82% (9) of these deaths.
- 50% (17) of all fatalities in 2015 involved more than one dog; 15% (5) involved a pack attack of four or more dogs; 21% (7) involved breeding on the dog owner's property either actively or in the recent past and 6% (2) involved tethered dogs.
- In 2015, 9% (3) of all fatal attacks were inflicted by dogs rehomed by shelters or rescues. County operated shelters in Buncombe County, North Carolina and Madison County, Tennessee each adopted out a dog that fatally attacked a person.
- Dog ownership information for 2015 shows that non-family dogs inflicted the majority of dog bite fatalities, 59% (20), up 12% from the 10-year average of 47%. Over two-thirds of all deaths, 71% (24), occurred on the dog owner's property.
- In 2015, only 9% (3) of attacks causing death resulted in meaningful criminal charges, the lowest level in the last 11-years.<sup>3</sup> 2015 also marked the first time a medical examiner ruled "suicide" as manner of death in a fatal dog attack.
- Texas once again led all states in lethal dog attacks in 2015 with 5 deaths. Florida and Oklahoma each followed incurring 3 deaths. Arkansas, California, Michigan, New York, North Carolina and West Virginia each followed with 2 deaths.

In the 11-year period of 2005 through 2015, canines killed 360 Americans. Pit bulls contributed to 64% (232) of these deaths. Combined, pit bulls and rottweilers contributed to 76% of the total recorded deaths. | [More »](#)

DogsBite.org - Animal control or health departments in at least 28 U.S. states report that pit bulls are out biting all other dog breeds, including: Arizona, Arkansas, California, Colorado, Delaware, Florida, Georgia, Illinois, Indiana, Iowa, Kansas, Massachusetts, Maryland, Michigan, Nebraska, Nevada, New York, North Carolina, Ohio, Oregon, Rhode Island, Pennsylvania, Tennessee, Texas, Utah, Virginia, Washington and Wisconsin. The oft-quoted claim by pro-pit bull groups that pit bulls "do not bite more than other breeds" is wholly false. Along with dominating bite counts, the pit bull bite is also the most damaging, often inflicting permanent and disfiguring injuries.

## Characteristics of 1616 Consecutive Dog Bite Injuries at a Single Institution

Published July 2016

Southeast (Atlanta, Georgia)

Pediatric Level 1 Trauma Center

[Download full study](#) | [open access](#)

Characteristics of 1616 Consecutive Dog Bite Injuries at a Single Institution, is a 4-year review of Children's Healthcare of Atlanta, a pediatric level I trauma center in Georgia. It is one of the largest retrospective studies and examines 1616 dog bite victims. The study refers back to eight different studies and their findings are consistent with six of them regarding pit bull injuries compared to other breeds of dogs: a higher frequency of injury and a higher degree of severity of injury.

Our data confirm what detractors of the breed and child advocates suggest -- that, with rare exceptions, children and pit bulls do not mix well. Of the 8 studies listed in Table 5, 6 report pit bulls as the most prevalent breed, and in many cases, they inflicted the most severe injuries. A large study at Children's Hospital of Pennsylvania showed that over a 12-year period, 25% of injuries were caused by a pit bull, and two-thirds of those required an operation. Our data were consistent with others, in that an operative intervention was more than 3 times as likely to be associated with a pit bull injury than with any other breed. Half of the operations performed on children in this study as well as the only mortality resulted from a pit bull injury. Our data revealed that pit bull breeds were more than 2.5 times as likely as other breeds to bite in multiple anatomical locations. Although other breeds may bite with the same or higher frequency, the injury that a pit bull inflicts per bite is often more severe. Consistent with these findings is that of Bini et al, who reported on 228 patients and found that attacks by pit bulls resulted in a higher injury severity score, lower Glasgow coma score, higher risk of death, and higher hospital charges than attacks by any other breed.

This study also emphasizes an increased risk of infants being injured by dogs. "Infants were more than 4 times as likely to be bitten by the family dog and more than 6 times as likely to be bitten in the head/neck region," the study states. [Table 3 examines injuries by age group](#). The 0 to 1-year old age group shows that 67% (97) were bitten by family dogs. Pit bulls inflicted 15 of these bites. The 5 to 12-year old group had the highest number of bites, 746. Pit bulls inflicted 13% (99).

**Karen Goodwin**

---

**From:** Christina Hoxworth <perfxn74@gmail.com>  
**Sent:** Sunday, February 19, 2017 10:18 PM  
**To:** Karen Goodwin  
**Subject:** Regarding the repeal of the pit bull ban

Dear Councilmembers,

I would like to request repeal of the ban on pit bull breeds by the city of Florissant. Please focus on the breed neutral aggressive dog ordinance. Thank you!

For Council and for Inclusion in Communications Portion of the February 28, 2017 Agenda.

Christina Hoxworth  
2370 Mockingbird  
63031

Sent from my iPhone

**Karen Goodwin**

---

**From:** Kristina Curnutt <kryscurnutt@gmail.com>  
**Sent:** Sunday, February 19, 2017 9:48 PM  
**To:** Karen Goodwin  
**Subject:** Regarding the repeal of the pit bull ban

Dear Councilmembers,

I would like to request repeal of the ban on pit bull breeds by the city of Florissant. Please focus on the breed neutral aggressive dog ordinance. Thank you!

For Council and for Inclusion in Communications Portion of the February 28, 2017 Agenda.

Kristina Curnutt  
1825 Arundel Dr  
Florissant MO 63033

**Karen Goodwin**

---

**From:** Frank Bougher <fbougher10538@gmail.com>  
**Sent:** Sunday, February 19, 2017 8:40 PM  
**To:** Karen Goodwin  
**Subject:** Breed Specific Legislation

To the city council as a whole,

I would like to see the City of Florissant, which I live in, repeal the Breed Specific Legislation against Pit Bulls. It is unfair and unjust for a breed to be discriminated against when we all know it is the irresponsible dog owners that produce vicious dogs, not a specific breed.

Please include my email on the next city council meeting agenda. I would like a reply verifying that my email has been received and will be included on the agenda. Thank you.

Frank Bougher  
1700 St. Francois St.  
Florissant, MO 63033



**Karen Goodwin**

---

**From:** joni chester <jonichester@hotmail.com>  
**Sent:** Wednesday, February 15, 2017 7:01 PM  
**To:** Karen Goodwin  
**Subject:** Fw: Pit bull ban

Ms. Goodwin,

Please add my voice to those asking for a repeal of the Florissant ban on pit bulls. I moved to Florissant from West County one year ago, and purchased a home in the Paddock Meadows subdivision. I love my new home and the area.

My daughter lives in West County and owns a 6 year old pit bull mix. Her dog is affectionately known as a "big baby" and is not at all aggressive. She recently discovered she is expecting a baby and may need to move back home with me. However, the pit bull ban will cause us to face a dilemma: she does not want to give up a pet she loves, and I do not want to move from Florissant. Repeal of the ban would allow us to avoid making a very difficult decision.

Thank you for your consideration of this matter.

Joni Chester  
6 Cornflower Court  
Florissant, MO 63033

**Karen Goodwin**

---

**From:** Bob Levin <bob\_levin@sbcglobal.net>  
**Sent:** Wednesday, February 15, 2017 2:04 PM  
**To:** Karen Goodwin  
**Subject:** To the Council as a whole Re: Pit Bull Ban ...

Please include my email on the agenda for the next Council meeting. I would like a reply verifying that my email has been received and will be included on the agenda. Thank you, Bob Levin

To the Council as a whole:

**Re: Pitbull ban...** This is to express my hope that you will NOT overturn the Pit Bull ban. I am a residential rental-property owner in Florissant, currently live just outside city boundaries (Shackelford Estates) and raised my 3 children in the wonderful City of Florissant. If you withdraw the ban, I will not invest in additional rental property in the city (I maintain my property at a high level). Don't be intimidated by the orange-shirted activists or by the framing of the Post-Dispatch article as a special-needs-child-victim issue as though only a Pit Bull (and not a Beagle, Collie, Lab, etc.) could comfort a child. The comparison of Dachshund bites with the vice-grip of a Pit Bull is ludicrous. And if a dangerous dog ordinance is supposed to suffice, how can such an ordinance be enforced until *after* a dangerous incident or injury? **Please maintain the Pit Bull ban.**

Bob Levin  
1847 Partridge Berry  
Florissant, Mo. 63031

**Karen Goodwin**

---

**From:** Harge, Constance <hargec@wustl.edu>  
**Sent:** Tuesday, February 21, 2017 10:56 AM  
**To:** Karen Goodwin  
**Subject:** Ban on Pit Bulls-council as a whole

Hi Karen,

Can you address this to the council as a "Whole" for the 2/28/17 agenda on Pit bulls.  
I wish the ban stay, due to I had a baby relative that died as a result of an attack by a pit bull.  
I feel by us lifting the ban, there will be more cases of pit bull attacks.  
Right now due to the ban, we don't have a lot of cases with pit bull attacks.

My home address is 3625 Parc Chateau Ln, Florissant MO 63033

Please include my email [cdharge@att.net](mailto:cdharge@att.net) for the next Council meeting.

I would like a reply verifying that my email has been received and will be included on the agenda.

Thanks  
Have a great Day!

Connie Harge  
314-413-1430

The materials in this message are private and may contain Protected Healthcare Information. If you are not the intended recipient, be advised that any unauthorized use, disclosure, copying, or the taking of any action in reliance on the contents of this information is strictly prohibited. If you have received this email in error, please immediately notify the sender via telephone or return mail.

 Washington University in St. Louis  
SCHOOL OF MEDICINE

---

The materials in this message are private and may contain Protected Healthcare Information or other information of a sensitive nature. If you are not the intended recipient, be advised that any unauthorized use, disclosure, copying or the taking of any action in reliance on the contents of this information is strictly prohibited. If you have received this email in error, please immediately notify the sender via telephone or return mail.

**Karen Goodwin**

---

**From:** Bill Johnson <billsplace@outlook.com>  
**Sent:** Tuesday, February 21, 2017 11:47 AM  
**To:** Karen Goodwin  
**Subject:** Repeal of Pit Bull Ban

To the Council as a Whole:

Please include my email on the agenda for the next Council meeting. I would like a reply verifying that my email has been received and will be included on the agenda.

My name is William Johnson. I reside at 2855 Parker Rd, Florissant.

The purpose of this email is to respectfully request your support in voting NOT to repeal the current ban on Pit Bull and related breeds of dogs in Florissant. I attempted to present my position on this subject at a Council Meeting several months ago. However, due to the number of individuals requesting to speak in support of a repeal, my presentation was limited to two minutes. Those speaking in support of the repeal were also limited to two minutes each, but due to the number of individuals, the organization pushing for the appeal actually were able to make their presentation in more than 30 minutes. That seems quite unfair, and for that reason, I would like to reiterate some facts that I attempted to present during my presentation.

A report published in the April 2011 issue of Annals of Surgery found that one person is killed by a put bull every 14 days, two people are insured by a put bull every day, and young children are especially at risk. The report concludes that, "these breeds should be regulated in the same way in which other dangerous species, such as leopards, are regulated." It should be pointed out that this report was shared with TIME by PETA, the world's largest animal-rights organization.

The Supreme Courts of 11 states have ruled that breed-specific legislation is, indeed constitutional. This position was affirmed by the United States Supreme Court on February 19th, 20087, by refusing to hear an appeal from the Ohio Supreme Court's decision.

While those supporting appeal of the ban attempt to place the entire weight of the breed's aggressive behavior on responsible owners, I simply cannot and will not accept this premise. While responsible owners are vital, the Pit Bulls aggression and attack behavior is part of the DNA. The same behavior that makes a heard dog heard and a pointer point. I'm certain that the Washtenaw County Michigan family were responsible owners Pit Bull owners and knew that no hard would come to any member of their family. They were wrong...their 10-year-old boy was mauled by the family pet and suffered severe injuries to his face, left arm and left ear. The owners have turned the dog over to their local Animal Control authorities and requested the dog be euthanized.

Again, I'm requesting that you not allow an incident of this nature to happen in Florissant by maintaining and enforcing the current city ordinance. I don't believe that any member of the council wants to have the blood of a child on their hands.

Thank You,

**Karen Goodwin**

---

**From:** Best Friends Animal Society <Legislative@bestfriends.org> on behalf of Jennifer Storace <info@bestfriends.org>  
**Sent:** Tuesday, February 21, 2017 1:32 PM  
**To:** Karen Goodwin  
**Subject:** Save tax dollars and pets: Repeal the breed discriminatory law

Feb 21, 2017

City Clerk Karen Goodwin  
Florissant, MO

Dear City Clerk Goodwin,

We all want safe and humane communities. As a Florissant resident, I ask that you repeal the breed-discriminatory ordinance targeting alleged "pit bull" terriers. The old ordinance is not only ineffective, but it is expensive to enforce and violates the property rights of responsible pet owners.

The city council should listen to its caring residents who attend city council meetings each month and act to repeal the ban. The city needs to move onto other important matters. Wentzville, Town & Country, Clayton and Manchester -- like numerous Missouri cities -- have all repealed "pit bull" laws. Florissant should follow their lead.

It is clear that breed discrimination goes against the tenets of community policing. How can people trust government officials if their well-behaved pets are seized for no reason? Do we really want to be known as a community that makes citizens get rid of their innocent pet dogs? The focus of any dangerous dog law should be on the behavior of the owner and the behavior of the dog.

Florissant should not embrace the discriminatory policies of Ferguson that include an ordinance targeting pit bull terriers. Our community is better than that. We should prohibit reckless owners from owning pets (as the city of Skokie, Illinois, has done), rather than penalize responsible pet owners for the alleged breed of their dogs.

In America, responsible dog owners who follow safety rules should be able to own whatever breed of dog they choose. It's that simple.

Thank you for your efforts to repeal the breed discriminatory law and make Florissant a community where people with pets want to live.

Sincerely,

Ms. Jennifer Storace  
23 Voyager Dr  
Saint Peters, MO 63376-4413  
(314) 312-9997  
[ymisoqt@gmail.com](mailto:ymisoqt@gmail.com)

Florissant City Council  
955 Rue St. Francois  
Florissant, MO 63031

2-20-2017

Dear Council members,

As a lifelong Florissant resident, I am writing again to express my disappointment and concern about the possible repeal of the Pit Bull law. This law is very reasonable and appropriate considering the well-documented history of people being severely injured or killed by these animals, REGARDLESS of how they became so aggressive or troublesome. And although these violent incidents may be due to owner neglect or irresponsibility, the end result is what matters. The safety and protection of Florissant citizens should be your only objective, not catering to the desires of a special-interest group. As elected officials it is your duty to represent and protect all Florissant citizens, and that duty includes enacting and enforcing laws that might be unpleasant or contrary to the beliefs of a small segment of the population. They certainly have other choices, including a different type of breed or pet, and the option to move to another community where the majority of people agree with their agenda.

By repealing this law you are not only endangering the people you are elected to serve, but also paving the way for probable legal action against the city if someone is eventually injured or killed in a pit bull attack. Finally, why isn't this issue being decided in true democratic fashion, by a vote of the people who live in this city? I think the only way to fairly and finally resolve this issue is with a municipal vote by I.D.-verified Florissant residents. If the majority decides to repeal the ban, than so be it. But PLEASE do not ignore your responsibility and repeal the law simply because a vocal minority feels their own selfish interests are more important than the safety of the rest of the population!

Sincerely,



Brian Griesemer  
2285 Johnstown Drive  
Florissant, MO 63033

**Karen Goodwin**

---

**From:** krikri5815 <krikri5815@yahoo.com>  
**Sent:** Wednesday, February 22, 2017 3:49 AM  
**To:** Karen Goodwin  
**Subject:** Fwd: Breed specific legislation

Sent from my Sprint Samsung Galaxy Note5.

----- Original message -----

**From:** krikri5815 <krikri5815@yahoo.com>  
**Date:** 1/18/17 7:52 PM (GMT-06:00)  
**To:** [kgoodwin@florissantmo.com](mailto:kgoodwin@florissantmo.com)  
**Subject:** Breed specific legislation

Ms Goodwin,

To the city council as a whole,  
My name is Kris Korte and I live at 105 Clark St Florissant MO 63031.  
I am writing to ask the mayor and council members to repeal the pit bull ban in Florissant!  
Please include this in the communications section in the council meeting.

Thank you,  
Kristin Korte

Sent from my Sprint Samsung Galaxy Note5.

**Karen Goodwin**

---

**From:** Tim Lee, Florissant Ward 1 <tleeward1@prodigy.net>  
**Sent:** Wednesday, February 22, 2017 10:40 AM  
**To:** Karen Goodwin  
**Subject:** Pit Bull Ban ....possibly being repealed. (I really do not wish to give my address)

Karen,

Ms Smith sent the e-mail without her address (below). I contacted her, and said our policy is not to make part of the record unless address is given. She sent me this e-mail saying she does want to be made part of the record so here is her address.

Tim Lee  
Florissant City Council  
Ward 1  
(314) 837-8875  
-----

**From:** AARON CHERYL SMITH <asmith1634@sbcglobal.net>  
**To:** Florissant Ward 1 Tim Lee <tleeward1@prodigy.net>  
**Sent:** Tuesday, February 21, 2017 8:57 PM  
**Subject:** Fw: Pit Bull Ban ....possibly being repealed. (I really do not wish to give my address)

On Tuesday, February 21, 2017 8:53 PM, AARON CHERYL SMITH <asmith1634@sbcglobal.net> wrote:

Mr. Lee,

I have reconsidered. Feel free to give out my address:

935 Saddle Drive  
Florissant, MO 63033  
314.838.3725

---

**From:** AARON CHERYL SMITH [mailto:asmith1634@sbcglobal.net]  
**Sent:** Tuesday, February 21, 2017 1:20 AM  
**To:** Karen Goodwin  
**Subject:** Pit Bull Ban ....possibly being repealed. (I really do not wish to give my address)

Dear Councilmen:

I am a dog lover, but I am not in favor of the Pit Bull Ban being repealed. I have viewed online the council meeting where people came to show support for the breed and voiced their opinions why Florissant should not ban a specific breed. I remember a realtor spoke, a lady from Chesterfield spoke from a pro-pit organization and her speech even brought me to tears as a dog owner, but these people do not live here. I have had many dogs come up to me off leash or from around their own yards while walking with my child, walking with my dog or walking myself over the years. I am not as frightened by a Cocker Spaniel as I am a Pit Bull or Chow. Granted, little dogs can spook easy and will nip or bite just the same if not more, but you usually are not looking at life-threatening injuries from one of these smaller breeds. Life threatening injuries or death to a child or a family pet is what makes me not comfortable with the Pit Bull ban possibly being repealed. I think it comes down to how safe you feel as a citizen out walking when you encounter a breed that could potentially be more aggressive. The size, manageability and temperament of the dog is a big factor.



I realize other municipalities do not have this ban as I called St. Charles County today and found out that St. Peters and O'Fallon, do not have bans. Well, I just hope Florissant doesn't back down simply because it is not deemed a popular thing to do, by banning a specific breed. I just want to encourage you to keep doing the right thing by the citizens of Florissant and keep the ban in place. Maybe we lose a few as the realtor said, but maybe we will gain a few more residents coming into the area or not leaving the area due to a bad Pit Bull population. Dogs do accidentally get out of yards and or break free from an owner's grip occasionally on a walk and then you have a potentially dangerous situation for an unknowing citizen out walking, running or biking.

I hear the Dangerous Dog Ordinance is maybe going to be tweaked if the Pit Bull Ban is repealed. Well, that is good for starters, but doesn't that actually mean there is now a victim of a Pit Bull attack? The victim of said attack ends up in the position of having to prove they were attacked by a dangerous dog and did not provoke the dog etc.? What if the victim is a child who died of their injuries or the family pet? If you truly want to repeal the Pit Bull Ban, then go ahead and say we are repealing it, but we will view all Pit Bulls as dangerous dogs due to the nature and reputation of the breed itself and their owners will be required to abide by that ordinance. They should have to abide by all the same stipulations as someone that has previously had a dog deemed "dangerous dog". They should have to have adequate fencing, muzzle when out walking on a leash and homeowner's policy to cover an attack adequately.

Lumping all Pit Bulls under the category of Dangerous Dog according to the ordinance, may still be a form of being stricter with this breed, but one that is a responsible one for Florissant and other municipalities for that matter. Please do not succumb to the pressures of a few responsible Pit Bull owners and advocates and repeal this ban. I do have sympathy for this breed and it's responsible owners and advocates. There is an injustice being done to this breed, but Florissant banning them is not where the problem began and is not where the problem will end. The problem started with the irresponsible owners and people that breed them for fighting. As a dog owner, it is your responsibility to know your dogs potential to do harm to others and so these dogs should be handled differently in Florissant if this ban is repealed. They should be muzzled on a walk at the bare minimum.

Thank you.

Cheryl Smith  
935 Saddle Dr  
(314) 838-3725

**Karen Goodwin**

---

**From:** Best Friends Animal Society <Legislative@bestfriends.org> on behalf of Sheila Swindle <info@bestfriends.org>  
**Sent:** Tuesday, February 21, 2017 4:32 PM  
**To:** Karen Goodwin  
**Subject:** Save tax dollars and pets: Repeal the breed discriminatory law

Feb 21, 2017

City Clerk Karen Goodwin  
Florissant, MO

Dear City Clerk Goodwin,

We all want safe and humane communities. As a Florissant resident, I ask that you repeal the breed-discriminatory ordinance targeting alleged "pit bull" terriers. The old ordinance is not only ineffective, but it is expensive to enforce and violates the property rights of responsible pet owners.

The city council should listen to its caring residents who attend city council meetings each month and act to repeal the ban. The city needs to move onto other important matters. Wentzville, Town & Country, Clayton and Manchester -- like numerous Missouri cities -- have all repealed "pit bull" laws. Florissant should follow their lead.

It is clear that breed discrimination goes against the tenets of community policing. How can people trust government officials if their well-behaved pets are seized for no reason? Do we really want to be known as a community that makes citizens get rid of their innocent pet dogs? The focus of any dangerous dog law should be on the behavior of the owner and the behavior of the dog.

Florissant should not embrace the discriminatory policies of Ferguson that include an ordinance targeting pit bull terriers. Our community is better than that. We should prohibit reckless owners from owning pets (as the city of Skokie, Illinois, has done), rather than penalize responsible pet owners for the alleged breed of their dogs.

In America, responsible dog owners who follow safety rules should be able to own whatever breed of dog they choose. It's that simple.

Thank you for your efforts to repeal the breed discriminatory law and make Florissant a community where people with pets want to live.

Sincerely,

Mrs. Sheila Swindle  
3244 Hilvin Dr  
Saint Louis, MO 63129-1732  
(314) 892-4003  
[ss396@charter.net](mailto:ss396@charter.net)

**Karen Goodwin**

---

**From:** Debbie Causevic <dcausevic@yahoo.com>  
**Sent:** Wednesday, February 22, 2017 9:08 AM  
**To:** Karen Goodwin  
**Subject:** Request to repeal Florissant's ban on pit bulls

Dear Council Members:

I would like to request repeal of the ban on pit bull breeds by the city of Florissant. Please focus on breed-neutral aggressive dog ordinances. Thank you!

Please include in the Council and Inclusion in Communications Portion of the February 28th Agenda.

Debbie Causevic  
471 Mission Bay Drive  
Wildwood, MO 63040

Best regards,  
Debbie Causevic

**Karen Goodwin**

---

**From:** Ken Pruett <kens20four@yahoo.com>  
**Sent:** Tuesday, February 21, 2017 5:58 PM  
**To:** Karen Goodwin  
**Subject:** dog ban

My name is Ken Pruett. I own a home in Florissant at 1750 Keeven Lane. I want the ban on Pitbulls repealed. Please put this on the communications section. Thanks.

Friends are forever and life is to short ..... God bless

**Karen Goodwin**

---

**From:** cheryl genail <cgenail@hotmail.com>  
**Sent:** Tuesday, February 21, 2017 4:26 PM  
**To:** Karen Goodwin  
**Subject:** To the City Council as a whole

I am a Florissant resident and I am requesting repeal of the breed specific ban! The ban is wrong and unfair. Please vote in favor to repeal the ban at the next city council meeting.

Please include my email on the next city council meeting agenda. I'd like a reply verifying that my email has been received and it will be included on the next agenda.

Thank you,

Cheryl Genail  
2000 Thrush Dr.  
Florissant, MO 63033

**Karen Goodwin**

---

**From:** Weiss, Nikki <NCWeiss@magellanhealth.com>  
**Sent:** Tuesday, February 21, 2017 4:07 PM  
**To:** Karen Goodwin  
**Subject:** Regarding the repeal of the pit bull ban

Dear Council Members,

I would like to request the repeal of the pit bull ban in the city of Florissant. While I do agree with the dangerous animal ordinance, I believe the additional legislation singling out pit bulls to be unnecessary and discriminatory. Please focus your energies on the breed-neutral dangerous animal ordinance. Thank you!

For Council and for Inclusion on the Communications portion of the February 28, 2017 agenda.

Thank you,  
Nikki Weiss  
216 Elmdale Ct.

Nikki Weiss  
IT Project Manager, Business Systems  
Magellan Health Services  
14100 Magellan Plaza  
O 314-387-4042 | E [ncweiss@magellanhealth.com](mailto:ncweiss@magellanhealth.com)  
[magellanhealth.com](http://magellanhealth.com)

**Magellan**  
HEALTH SERVICES



\*\*\*Confidentiality Notice\*\*\*

This electronic message transmission contains information belonging to Magellan Health Services that is solely for the recipient named above and which may be confidential or privileged. MAGELLAN HEALTH SERVICES EXPRESSLY PRESERVES AND ASSERTS ALL PRIVILEGES AND IMMUNITIES APPLICABLE TO THIS TRANSMISSION. If you are not the intended recipient, be aware that any disclosure, copying, distribution or use of this communication is STRICTLY PROHIBITED. If you have received this electronic transmission in error, please notify us by telephone at (314) 387-4000. Thank you.

**Karen Goodwin**

---

**From:** Amanda Heger <amandahegerwrites@gmail.com>  
**Sent:** Wednesday, February 22, 2017 4:38 PM  
**To:** Karen Goodwin  
**Subject:** Repeal Breed Specific Legislation

Dear Council Members,

Please repeal the ban on "pit bull breeds" in Florissant. Breed specific legislation (BSL) has been deemed ineffective by the National Canine Research Council. The American Bar Association has also called for an end to BSL, and the Centers for Disease Control has recommended against using breed as a factor in dog-bite prevention policy.

These types of ordinances are nearly impossible to enforce accurately, as "pit bull" is a generalized term that encompasses many breeds and mixed breeds of dog. In fact, the National Canine Research Council states that "breed labels assigned to dogs of unknown origin are often inaccurate, and observers often don't agree on visual breed identification."

BSL is also costly. Such ordinances significant incur cost associated with law suits, confiscations, and impoundment. In a 2003 study, one Maryland county spent more than half a million dollars on confiscations alone over the course of two years. This number did not include the costs of manpower, overtime, or utilities to house the confiscated dogs.

Additionally, there is no evidence from controlled studies that suggests one breed of dog is more likely to bite than another. In one study published in the *Journal of the American Veterinary Medical Association*, researchers were able to identify multiple, controllable factors in dog-bite fatalities. Breed was *not* such a factor. In fact, according to the American Temperament Test Society, "pit bull" type dogs consistently pass temperament testing at rates well above most other breeds.

Finally, BSL punishes responsible pet owners and prevents taxpayers from moving to your city. For example, when I was searching for a home in the St. Louis area, I often came across promising real estate in Florissant, which is a very convenient location to my office. However, because I am a pit bull owner, I could not and would not consider living in a city with BSL.

Please put an end to the inaccurate, costly, and ineffective practice of BSL.

For Council and inclusion in communications portion of the February 28th agenda.

--  
Amanda Heger  
270 Lucille Ave  
St. Louis, MO 63119

Website

**Karen Goodwin**

---

**From:** grfarmerjr@sbcglobal.net  
**Sent:** Wednesday, February 22, 2017 10:56 PM  
**To:** Karen Goodwin  
**Cc:** Ward 9 Tommy Siam; Mayor Schneider  
**Subject:** Do Not Repeal Pit Bull Ban

To the Council as a whole,

This message is to voice the concern of the five (5) registered voters in our household.

We do not want the City of Florissant to repeal the Pit Bull Ban.

This would be a big mistake.

Please let me know if we need to let anyone else in Florissant City Government know our concern.

Also, please include our email on the agenda for the next Council meeting. We would like a reply verifying that our email has been received and will be included on the agenda.

Thanks.

- Bob Farmer
- Garalyn Farmer
- Molly Farmer
- Benjamin Farmer
- Brendan Farmer

74 Club Grounds North  
Florissant, MO 63033

314-705-0247 (cell)  
314-838-3548 (home)

---

**From:** [grfarmerjr@sbcglobal.net](mailto:grfarmerjr@sbcglobal.net) <[grfarmerjr@sbcglobal.net](mailto:grfarmerjr@sbcglobal.net)>  
**Sent:** Thursday, February 16, 2017 3:55 PM  
**To:** Ward 9 Tommy Siam  
**Cc:** Lou Jearls  
**Subject:** Do Not Repeal Pit Bull Ban

Tony,

I wanted to voice the concern of the five (5) registered voters in my household.



We do not want the City of Florissant to repeal the Pit Bull Ban.

This would be a big mistake.

Please let me know if we need to let anyone else in Florissant City Government know our concern.

Thanks.

- Bob Farmer

74 Club Grounds North  
Florissant, MO 63033

314-705-0247 (cell)

**Karen Goodwin**

---

**From:** Best Friends Animal Society <Legislative@bestfriends.org> on behalf of Yvonne Wolf <info@bestfriends.org>  
**Sent:** Wednesday, February 22, 2017 9:27 PM  
**To:** Karen Goodwin  
**Subject:** Save tax dollars and pets: Repeal the breed discriminatory law

Feb 22, 2017

City Clerk Karen Goodwin  
Florissant, MO

Dear City Clerk Goodwin,

We all want safe and humane communities. As a Florissant resident, I ask that you repeal the breed-discriminatory ordinance targeting alleged "pit bull" terriers. The old ordinance is not only ineffective, but it is expensive to enforce and violates the property rights of responsible pet owners.

The city council should listen to its caring residents who attend city council meetings each month and act to repeal the ban. The city needs to move onto other important matters. Wentzville, Town & Country, Clayton and Manchester -- like numerous Missouri cities -- have all repealed "pit bull" laws. Florissant should follow their lead.

It is clear that breed discrimination goes against the tenets of community policing. How can people trust government officials if their well-behaved pets are seized for no reason? Do we really want to be known as a community that makes citizens get rid of their innocent pet dogs? The focus of any dangerous dog law should be on the behavior of the owner and the behavior of the dog.

Florissant should not embrace the discriminatory policies of Ferguson that include an ordinance targeting pit bull terriers. Our community is better than that. We should prohibit reckless owners from owning pets (as the city of Skokie, Illinois, has done), rather than penalize responsible pet owners for the alleged breed of their dogs.

In America, responsible dog owners who follow safety rules should be able to own whatever breed of dog they choose. It's that simple.

Thank you for your efforts to repeal the breed discriminatory law and make Florissant a community where people with pets want to live.

Sincerely,

Mrs. Yvonne Wolf  
1432 Mokane Rd Apt 412  
Fulton, MO 65251-2950  
(423) 246-8452  
[geovonni@aol.com](mailto:geovonni@aol.com)

# **CITY OF FLORISSANT**

## **Public Hearing**



**In accordance with 405.310 of the Florissant Zoning Code a Public Hearing will be held by the City Council of Florissant, MO. in the Council Chambers, 955 Rue St. Francois, on Tuesday, February 28, 2017 at 7:30 P.M. on the following proposition:**

**To authorize an amendment to Special Use Permit No. 8029 to Burger King to allow for renovations to the existing building in an B-3 Zoning District for the property located at 3121 N. Highway 67 (legal description to govern). Citizens will have an opportunity to be heard. Anyone with special needs should contact the City Clerk at least 5 days before said public hearing by calling 839-7630 or TDD 839-5142.**

**CITY OF FLORISSANT, Karen Goodwin, MMC City Clerk**

FLORISSANT PLANNING & ZONING COMMISSION APPLICATION

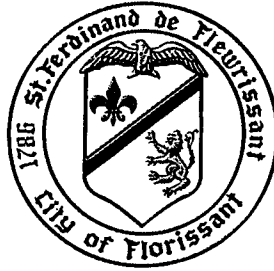

City Of Florissant – Public Works 314-839-7648

"Preserve and improve the health, safety, and welfare of our residents, businesses and the general public in the City of Florissant; while at the same time maintaining property values and improving the quality of life in the City of Florissant."

Application is hereby made to the Building Commissioner, Department of Public Works at the City of Florissant, Missouri, to appear before the Planning & Zoning Commission.

Please Print neatly or Type the Following Information:

Property Address: 3121 N Highway 67 Florissant, MO 63033

Property Owners Name: Broadway Restaurant Group Phone/email: brad@b-restaurants.com

Property Owners Address: 240 Centre Street, New York, NY 10013

Business Owners Name: Broadway Restaurant Group phone/email: brad@b-restaurants.com

Business Owners Address: 240 Centre Street, New York, NY 10013

DBA (Doing Business As) \_\_\_\_\_

Authorized Agents Name: Bart Berneking Co. Name: Bart Berneking Design + Build  
(Authorized Agent to Appear Before The Commission)

Agents Address: 100 Professional Parkway, Troy, MO 63379 Phone/email: (314) 574-5186 / bart@bartberneking.com

Request Renovation / Remodel of existing Burger King restaurant. Location will remain Burger King restaurant.

State complete request (print or type only). AMEND Special Use Ord. #8029

IF A TRAFFIC STUDY IS REQUIRED FOR CERTAIN DEVELOPMENTS AND USES THE COST OF THE TRAFFIC STUDY SHALL BE PAID BY THE APPLICANT. PLEASE SUBMIT FOLDED PLANS

[Signature]  
Applicant's Signature

1-13-17  
Date

Received by: [Signature] Receipt # 598277 Amount Paid: 125.00 Date: 1/17/17

STAFF REMARKS: \_\_\_\_\_

COMMISSION ACTION TAKEN: \_\_\_\_\_

DATE APPLICATION REVIEWED: 1-30-17  
[Signature]  
SIGNATURE OF STAFF WHO REVIEWED APPLICATION

RECOMMENDED APPROVAL  
PLANNING & ZONING  
CHAIRMAN

SIGN. [Signature] DATE: 2/6/17

**SPECIAL USE PERMIT APPLICATION  
TO THE CITY OF FLORISSANT  
PLANNING AND ZONING COMMISSION**

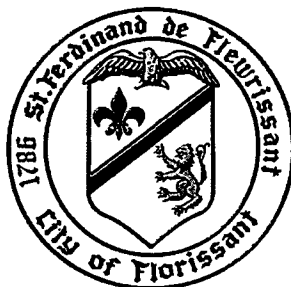

City Of Florissant – Public Works  
314-839-7648

*"Preserve and improve the health, safety, and welfare of our residents, businesses and the general public in the City of Florissant; while at the same time maintaining property values and improving the quality of life in the City of Florissant."*

**PLANNING & ZONING ACTION**  
**RECOMMENDED APPROVAL**  
**PLANNING & ZONING**  
**CHAIRMAN**

Council Ward \_\_\_\_\_ Zoning \_\_\_\_\_

Initial Date Petitioner Filed \_\_\_\_\_  
Building Commissioner to complete  
ward, zone & date filed

SIGN. [Signature] DATE: 2/6/17

SPECIAL PERMIT FOR Quick serve restaurant with drive-thru  
Statement of what permit is being sought. (i.e., special permit for operation of a restaurant).

AMEND SPECIAL PERMIT # 8029 TO ALLOW FOR renovations  
ordinance # Statement of what the amendment is for.

LOCATION 3121 N. Highway 67, Florissant, MO 63033  
Address of property.

1) Comes Now Broadway Restaurant Group LLC  
Enter name of petitioner. If a corporation, state as such. If applicable include DBA (Doing Business As)

and states to the Planning and Zoning Commission that he (she) (they) has (have) the following legal interest in the tract of land located in the City of Florissant, State of Missouri, as described on page 3 of this petition.

Legal interest in the Property) Owner - see attached  
State legal interest in the property. (i.e., owner of property, lease).  
Submit copy of deed or lease or letter of authorization from owner to seek a special use.

2) The petitioner(s) further state(s) that the property herein described is presently being used for Quick Serve restaurant w/ drive thru and that the deed restrictions for the property do not prohibit the use which would be authorized by said Permit.

3) The petitioner(s) further states (s) that they (he) (she) are submitting a detailed site plan of the proposed or existing development showing location and use of all structures, off-street parking, and all other information required by the Zoning Ordinance or determined necessary by the Building Commissioner.

4) The petitioner(s) further state(s) that (he) (she) (they) shall comply with all of the requirements of the City of Florissant, including setback lines and off- street parking.

5) The petitioner (s) further (represent (s) and warrants (s) that they (he) (she) has (have) not made any arrangement to pay any commission gratuity or consideration, directly or indirectly to any official, employee or appointee of the City of Florissant, with respect to this application.

6) The petitioner(s) further state (s) that the Special Use Permit is sought for the following purposes, and no other, as listed in detail, all activities sought to be covered by the permit (i.e.; operation of a business, approval of building and/or site plans (preliminary and / or final), plan approval for signage, etc.):

7) The petitioner (s) state (s) the following factors and reason to justify the permit:  
(If more space is needed, separate sheets maybe attached)

Brad Eaton [Signature] 1. brad@b-restaurants.com 314-803-8030  
PRINT NAME SIGNATURE email and phone

FOR Broadway Restaurant Group LLC  
(company, corporation, partnership)

Print and sign application. If applicant is a corporation or partnership signature must be a CORPORATE OFFICER or a PARTNER. NOTE: Corporate officer is an individual named in corporate papers.

8) I (we) hereby certify that, as applicant (circle one of the following):

1. I (we) have a legal interest in the herein above described property.

2. I am (we are) the duly appointed agent(s) of the petitioner (s), and that all information given here is true and a statement of fact.

Permission granted by the Petitioner assigning an agent (i.e. Architect) to present this petition in their behalf, to the Commission and/or Council. The petitioner must sign below, and provide contact information:

PRESENTOR SIGNATURE [Signature]

ADDRESS 100 Professional Pkwy, Troy, MO 63379  
STREET CITY STATE ZIP CODE

TELEPHONE / EMAIL (314) 574-5186 1bart@bartberneking.com  
BUSINESS

I (we) the petitioner (s) do hereby appoint Bart Berneking as  
my (our) duly authorized agent to represent me (us) in regard to this petition.  
Print name of agent.

[Signature]  
Signature of Petitioner authorizing an agent

**NOTE:** When the petitioner and/or his duly authorized agent appears before the Planning and Zoning Commission and to make a presentation, the same individuals must also appear before the City Council at the Public Hearing to make the presentation and no one else will be permitted to make the presentation to the City Council without authorized approval.

IF DESCRIPTIONS, PLATS OR SURVEYS ARE INACCURATE, OR IF THE PETITION APPLICATION IS NOT CORRECT OR COMPLETE, IT WILL BE RETURNED FOR ADDITIONS OR CORRECTIONS.

**REQUIRED INFORMATION**

Please mark an "X" in the appropriate type of operation, then fill in applicable section (a), (b) or (c). Corporations are to submit copy of Missouri corporate papers with registration papers.

1) Type of Operation:  
Individual \_\_\_\_\_ Partnership X Corporation \_\_\_\_\_

(a) If an individual:

- (1) Name and Address \_\_\_\_\_
- (2) Telephone Number \_\_\_\_\_
- (3) Business Address \_\_\_\_\_
- (4) Date started in business \_\_\_\_\_
- (5) Name in which business is operated if different from (1) \_\_\_\_\_
- (6) If operating under a fictitious name, provide the name and date registered with the State of Missouri, and a copy of the registration.

(b) If a partnership:

- (1) Names & addresses of all partners Winterhut Inc, Watersedge Capital LLC, Brad Eaton
- (2) Telephone numbers 314-803-8030
- (3) Business address 240 Centre St, Unit 2N, New York NY 10013  
*Mailing / Local Address: 11854 Lacleand, St Louis Mo 63146*
- (4) Name under which business is operated Broadway Restaurant Group LLC
- (5) If operating under fictitious name, provide date the name was registered with the State of Missouri, and a copy of the registration.

(c) If a corporation:

- (1) Names & addresses of all partners \_\_\_\_\_
- (2) Telephone numbers \_\_\_\_\_
- (3) Business address \_\_\_\_\_
- (4) State of Incorporation & a photocopy of incorporation papers \_\_\_\_\_
- (5) Date of Incorporation \_\_\_\_\_
- (6) Missouri Corporate Number \_\_\_\_\_
- (7) If operating under fictitious name, provide the name and date registered with the State of Missouri, and a copy of registration. \_\_\_\_\_
- (8) Name in which business is operated \_\_\_\_\_
- (9) Copy of latest Missouri Anti-Trust. (annual registration of corporate officers) If the property location is in a strip center, give dimensions of your space under square footage and do not give landscaping information.

**PROVIDE LEGAL DESCRIPTION OF PROPERTY PERTAINING TO THIS PETITION**

(Close legal description with acreage to the nearest tenth of an acre).

Provide a legal description of the property. If part of a shopping center, list address and show part of what shopping center (i.e.: 351 N. Highway 67 part of Florissant Meadows Shopping Center). If property is a single lot, list full written legal description with metes and bounds bearings and dimensions.

**PROVIDE LOCATION MAP SHOWING AREA INVOLVING THIS PETITION**

Provide a drawing of a location map showing the nearest major intersection.

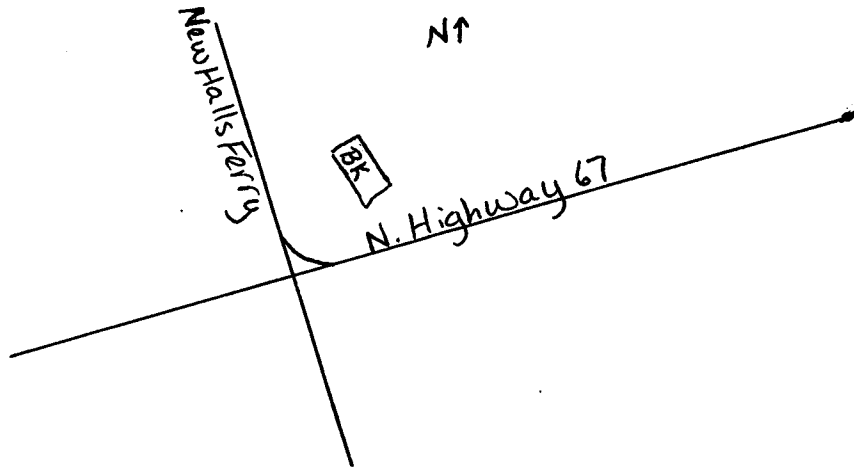

---

**OFFICE USE ONLY**

Date Application reviewed \_\_\_\_\_

STAFF REMARKS: \_\_\_\_\_

\_\_\_\_\_

\_\_\_\_\_

\_\_\_\_\_

\_\_\_\_\_  
Building Commissioner or Staff Signature



1 INTRODUCED BY COUNCILMAN SCHILDROTH  
2 MARCH 10, 2014

5 BILL NO. 8980

ORDINANCE NO. 8029

7 **AN ORDINANCE GRANTING A SPECIAL USE PERMIT CROSS KEYS**  
8 **RESTAURANT GROUP, LLC D/B/A BURGER KING TO ALLOW FOR**  
9 **THE LOCATION AND OPERATION OF A SIT DOWN, CARRY-OUT**  
10 **AND DRIVE-THROUGH RESTAURANT FOR THE PROPERTY**  
11 **LOCATED AT 3121 N HIGHWAY 67.**

14 WHEREAS, the Florissant Zoning Ordinance authorizes the City Council of the City of  
15 Florissant, by Special Use Permit, after public hearing thereon, to permit the location and  
16 operation of a restaurant; and

17 WHEREAS, an application has been filed by Cross Keys Restaurant Group, LLC d/b/a  
18 Burger King to allow for the location and operation of a restaurant on the property known as  
19 3121 N. Highway 67; and

20 WHEREAS, the Planning and Zoning Commission of the City of Florissant, at their  
21 meeting of February 18, 2014, has recommended that the said Special Use Permit be granted; and

22 WHEREAS, due notice of public hearing no. 14-03-008 on said application to be held on  
23 the 10<sup>th</sup> of March, 2014, by the Council of the City of Florissant was duly published, held and  
24 concluded; and

25 WHEREAS, the Council, following said public hearing, and after due and careful  
26 consideration, has concluded that the granting of the Special Use Permit as hereinafter provided  
27 would be in the best interest of the City of Florissant.

28 NOW, THEREFORE, BE IT ORDAINED BY THE COUNCIL OF THE CITY OF  
29 FLORISSANT, ST. LOUIS COUNTY, MISSOURI, AS FOLLOWS:

31 Section 1: A Special Use Permit is hereby granted to Cross Keys Restaurant Group, LLC  
32 d/b/a Burger King to allow for the location and operation of a restaurant on the property known  
33 as 3121 N. Highway 67.

34 Section 2: The said Special Use Permit herein authorized shall remain in full force and  
35 effect and subject to all of the ordinances of the City of Florissant.

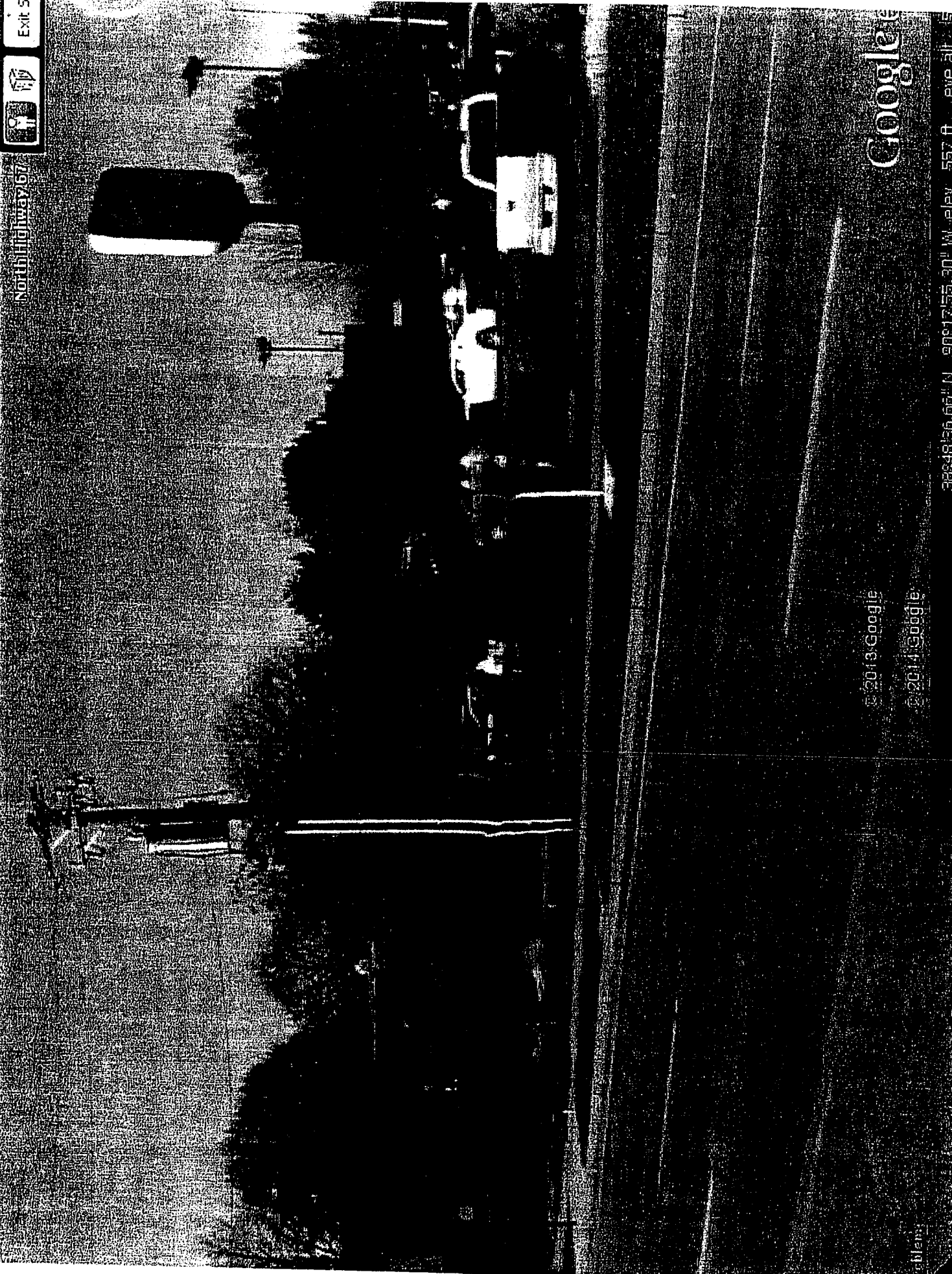

Exit 5

North Highway 67

© 2013 Google

© 2014 Google

Google

38°48'36.66" N 90°17'55.30" W elev 557 ft eye alt 5

3121 n highway

Go

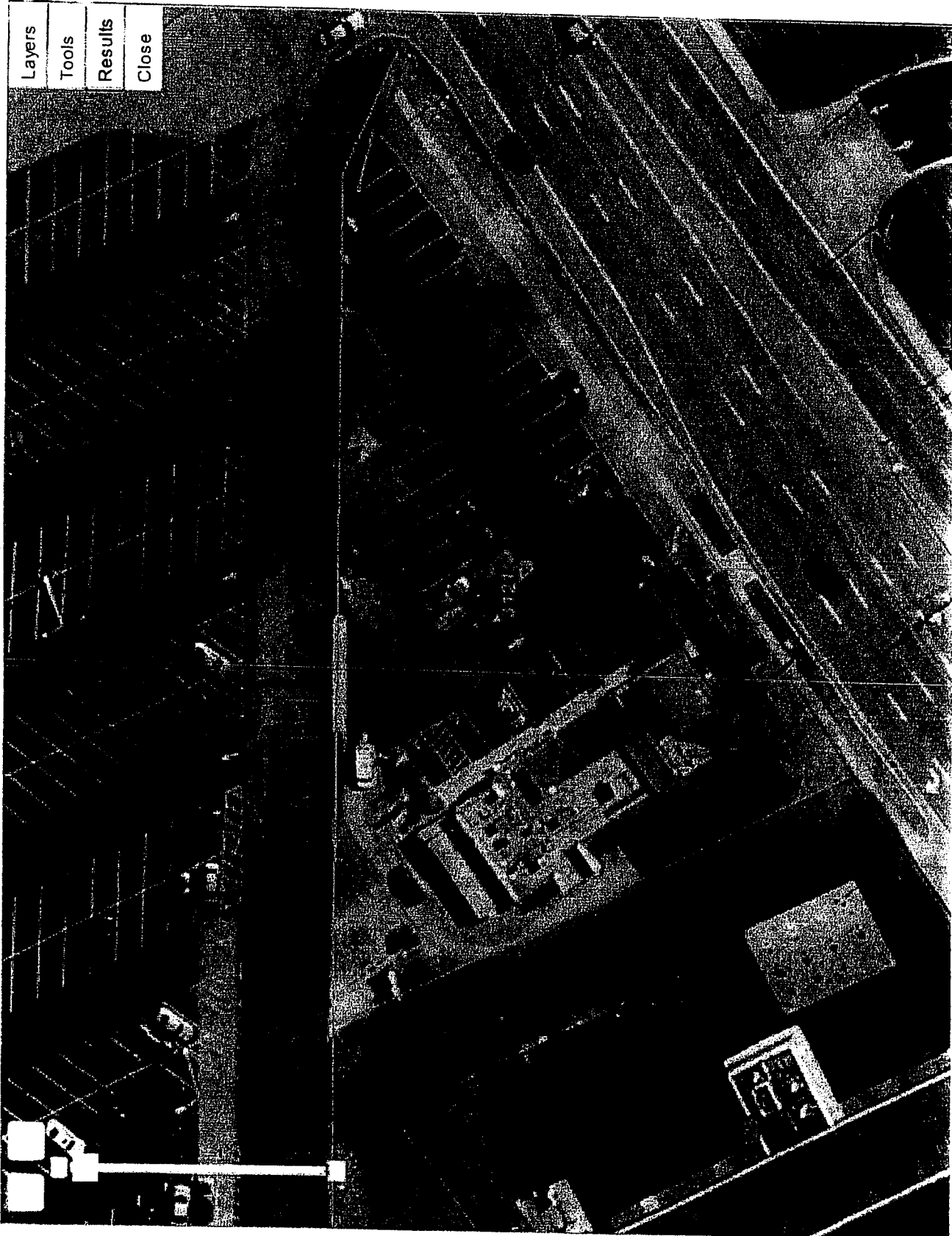

Layers

Tools

Results

Close

Clear Pa

07H53011

Parcel ID:

Address:

Owner:

Appraised Value:

Subdivision

Municipality

County

Council:

Fire District

School District:

Trash Distri

Census Tra

FIRM Panel

Zoning:

External

Links:

1

MEMORANDUM

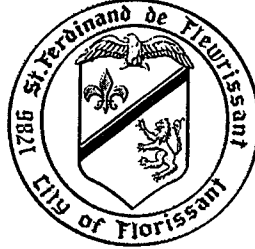

CITY OF FLORISSANT

"Preserve and improve the health, safety, and welfare of our residents, businesses and the general public in the City of Florissant; while at the same time maintaining property values and improving the quality of life in the City of Florissant."

2

3

4

5

6

7

To: Planning and Zoning Commissioners Date: January 31, 2017

8

9

From: Philip E. Lum, AIA-Building Commissioner cc: Louis B. Jearls, Jr.- P.E., PWLF  
Director of Public Works  
Applicant  
File

10

11

12

13

14

15

16

17

18

Subject: Request recommended approval to amend a Special Use, ordinance 8029, 3121 N Highway 67 (Burger King) to allow for renovations of a Sit-down, carry-out, drive through restaurant in a 'B-3' Extensive Business District.

18

19

**STAFF REPORT**

**CASE NUMBER PZ-020617-1**

19

20

21

22

23

**I. PROJECT DESCRIPTION:**

22

23

24

This is a request for Recommended Approval to amend a Special Use, ordinance 8029, 3121 N Highway 67 (Burger King) to allow for renovations of a Sit-down, carry-out, drive through restaurant in a 'B-3' Extensive Business District.

25

26

27

28

29

30

**II. EXISTING SITE CONDITIONS:**

30

31

32

33

34

35

The existing property at 3121 N Highway 67 is occupied by a Burger King chain restaurant establishment. In 2014, Ordinance 8029 established a Special Permit at this location but without a published development plan. The site is an outlot of the Flower Valley Shopping Center which has multiple tenants. The site is predominantly paved with existing parking and landscaping.

35

36

The subject building on the property contains 3130 square feet on a site of 3/4 acre. There is no proposed sign change to the existing post sign.

36

37

38

39 There are 34 existing parking spaces and adequate drive-through lane. The parking  
40 would support a crew of 6 employees and 128 seating.  
41

42

43 **III. SURROUNDING PROPERTIES:**

44 The properties surrounding are all in the 'B-3' Zoning District.  
45

46

47

48 **IV. STAFF ANALYSIS:**

49 The application is accompanied by professionally prepared renovation plans including:  
50 ST1, A1, A2.1 and A2.2 all dated 1/12/17 as prepared by Tevis Architects for the  
51 petitioner, Bart Berneking- Design Builder.

52

53 The existing post sign appears to be located approximately 25-30 feet from the right-of-  
54 way near the end of the drive through lane adjacent to the Westernmost parking space in  
55 the aisle adjacent to the highway.

56

57 Staff comments per drawing submitted.

58

59 Drawing ST1:

60

61

62

63

64

65

66

67

68

69

70

71

72

73

74

75

76

77

78

79

80

81

82

83

Drawing A1:

- New patio is shown to be <sup>20'</sup>~~38'~~ x 28'. If intended for customer outdoor activity, should be protected from vehicles.
- Floor Plan indicates the building is accessed on all 4 sides by either customers or staff.

Drawing A2.1:

- Includes a schedule of all proposed exterior materials including brick, fiber-cement brick panels, ceramic tile, 'STO' stucco, paint and metal coping, canopies and awning. Sign is noted as 6' diameter.

Drawing A2.2:

- South Elevation: Proposed design incorporates all the new materials in combination with a red LED light band at the top of the wall.

## V. MASONRY ORD. ANALYSIS

This proposal calls for all brick to be painted. Painting of brick is only permitted if granted by Council under a Special Use:

*Section 500.040 Frame Construction in "R-6", "B-1", "B-2", "B-3", "B-4", "B-5", "M-1", "M-2" and "M-3" Zoning Districts. [Code 1980 § 6-8; CC 1990 § 5-5; Ord. No. 4926 § 1, 7-11-1988; Ord. No. 5318, 1-27-1992; Ord. No. 6224, 1-25-1999; Ord. No. 7437 § 1, 8-20-2007; Ord. No. 7671 § 1, 1-13-2010]*

*A. Any building as defined in the Building Code, as adopted by Chapter 505, which is located in an "R-6", "B-1", "B-2", "B-3", "B-4", "B-5", "M-1", "M-2" or "M-3" zoning district shall have exterior finished walls composed of one hundred percent (100%) masonry on all sides of structure, except as otherwise permitted by this Section. There shall be no exposed non-masonry surfaces in the first (1st) three (3) feet above grade except doors and windows.*

*Exceptions:*

*1. Accessory buildings if otherwise permitted by ordinance and approved by the planning and zoning commission;*  
*2. Buildings specifically excepted from such requirement under provisions of a special permit or a "B-5" zoning ordinance granted by the Council in accordance with provisions of Chapter 405 of the Code;*

*3. Tilt-up construction is allowed on buildings of twenty thousand (20,000) square feet or greater provided that the front tilt-up face of the building shall be constructed with traditional masonry material unless otherwise determined by the City Council. "Traditional masonry" is defined as hand-laid in place traditional block back-up, brick, stone or any other masonry material as a face. Decorative and/or embossed tilt-up panels may be required on all other portions of the building. Tilt-up construction is the process of forming, pouring and curing Portland cement concrete panels on the job site and tilting/raising them up into place usually as the exterior wall of a building or structure. Tilt-up is different than pre-cast panels which are constructed off site.*

*4. Any buildings legally existing on or for which building permits have been legally issued prior to March 1, 1992, or any reconstruction thereof or any alterations and expansion thereof if approved by the Planning and Zoning Commission.*

*B. "Masonry", as used in this Section, shall be defined as exposed face brick or natural building stone which is used as a facing component which is applied over exterior wall back-up construction. Face brick shall be prismatic units in a variety of sizes, colors and shapes. Brick shall be manufactured from clay, shale or similar naturally occurring earthy substances and subjected to firing in a kiln. Brick shall be solid masonry units, having a minimum thickness of three and five-eighths (3 5/8) inches and meeting all the requirements of ASTM Designation C-216, Standard Specification for Facing Brick. Ceramic glazed facing brick are specifically excluded. Natural building stone shall include stone that is sawed, cut, split or otherwise finished or shaped having a minimum thickness of one (1) inch. Natural building stone shall include granite, limestone, marble, slate, soapstone, sandstone or other natural stones of similar characteristics and physical properties. Molded, cast or otherwise artificially aggregated units composed of fragments are specifically excluded. Materials specifically excluded from the definition of exposed masonry construction shall include, but shall not be limited to: all hollow masonry units (i.e., structural clay tile, facing tile, customized architectural concrete masonry units, hollow brick units, etc.), all concrete masonry units, glass blocks, plastic and/or composite blocks, metal panels, plastic panels, plaster exterior insulation-finish system, precast concrete panels or any composition and all cast-in-place concrete walls, tilt-up concrete panels.*

*C. Restrictions On Use Of Masonry.*

*1. Masonry shall not be painted, but clear sealers may be applied if approved by the Building Commissioner.*

*2. Any masonry that was lawfully painted may only be repainted for maintenance purposes and only with written permission from the Director of Public Works. In cases where there is a need to perform maintenance on a painted area, the Director of Public Works or their designee may review and approve any repainting for maintenance reasons, provided that there is no change in color or texture.*

*3. Repainting for reasons other than for maintenance of current painted surfaces upon the approval of the Director of Public Works and requests to change the color or texture of the existing brick or masonry surface may not be done without the review and recommendation from Planning and Zoning Commission and approval of City Council.*

*4. Nothing contained herein shall excuse or authorize the unlawful painting or repainting of brick or masonry surfaces.*

*5. Exemption for Landmark and Historic Homes: All buildings listed on the National Register of Historic Places, designated Florissant landmarks or structures eligible to be designated Florissant landmarks which were painted prior to the adoption of this Section would be excluded from its provisions.*

## VI. STAFF RECOMMENDATIONS:

### **Suggested Motion for 3121 N Highway 67 (Burger King) :**

I move to recommend approval recommended approval to amend a Special Use, ordinance 8029, 3121 N Highway 67 (Burger King) to allow for renovations of a Sit-down, carry-out, drive through restaurant in a 'B-3' Extensive Business District, as depicted on the application documents: ST1, A1, A2.1 and A2.2 all dated 1/12/17 as prepared by Tevis Architects, subject to the regulations in the 'B-3' "Extensive Business District", and the following additional requirements:

1) no paint brick

2) screen RTV unit

3) badlands on east patio side.

145  
146  
147  
148  
149  
150  
151  
152  
153  
154  
155  
156  
157  
158  
159  
160  
161  
162

**1. GENERAL DEVELOPMENT CONDITIONS.**

- a. Unless, and except to the extent, otherwise specifically provided in ordinance no. 8029, development shall be effected only in accordance with all ordinances of the City of Florissant.

**2. PROJECT COMPLETION.**

Construction shall start within 90 days of the issuance of building permits for the project and shall be developed in accordance of the approved final development plan within 180 days of start of construction.

(End of report and suggested motion 1/31/17)

(end report)

# BURGER KING #4671

REMODEL

3121 N. HIGHWAY 67  
FLORISSANT, MO 63033

Architect



TEVIS ARCHITECTURAL GROUP  
833 DORRILL ST. 2ND  
LEWIS, MO 64575  
P: 913.397.2400  
F: 913.397.2913  
C: 816.374.6794  
CONTACT: LISA W. STANKS  
EMAIL: LISA@TEVISARCHITECTS.COM  
TEVISARCHITECTS.COM

Design Consultant



www.BartBermeking.com 636.462.1380

RECOMMENDED APPROVAL  
PLANNING & ZONING  
CHAIRMAN

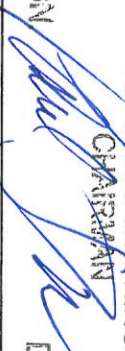
SIGN  DATE: 2/6/17



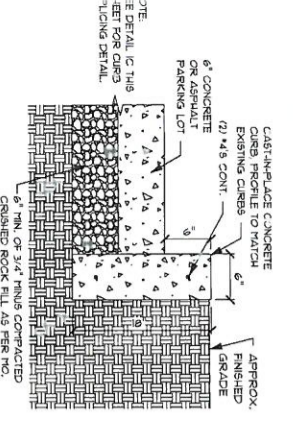

1) **DETAIL 5- 6" CONCRETE CURB DETAIL**  
SCALE: 1" = 1'-0"

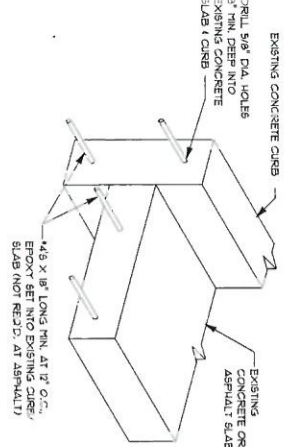

1) **DETAIL 6- CURB & SLAB SPICE DETAIL**  
SCALE: N.T.S.

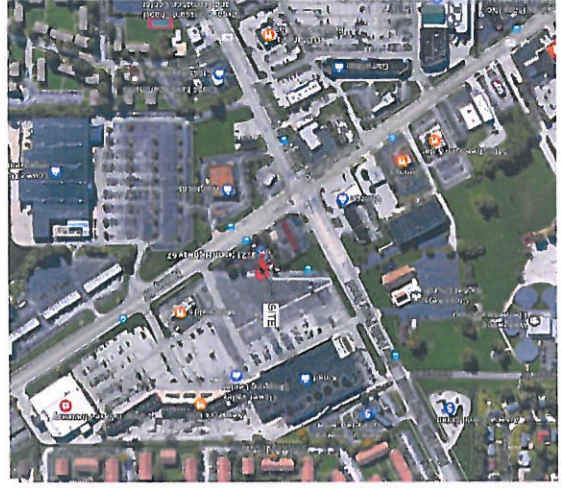

1) **SITE LOCATION MAP**  
SCALE: N.T.S.

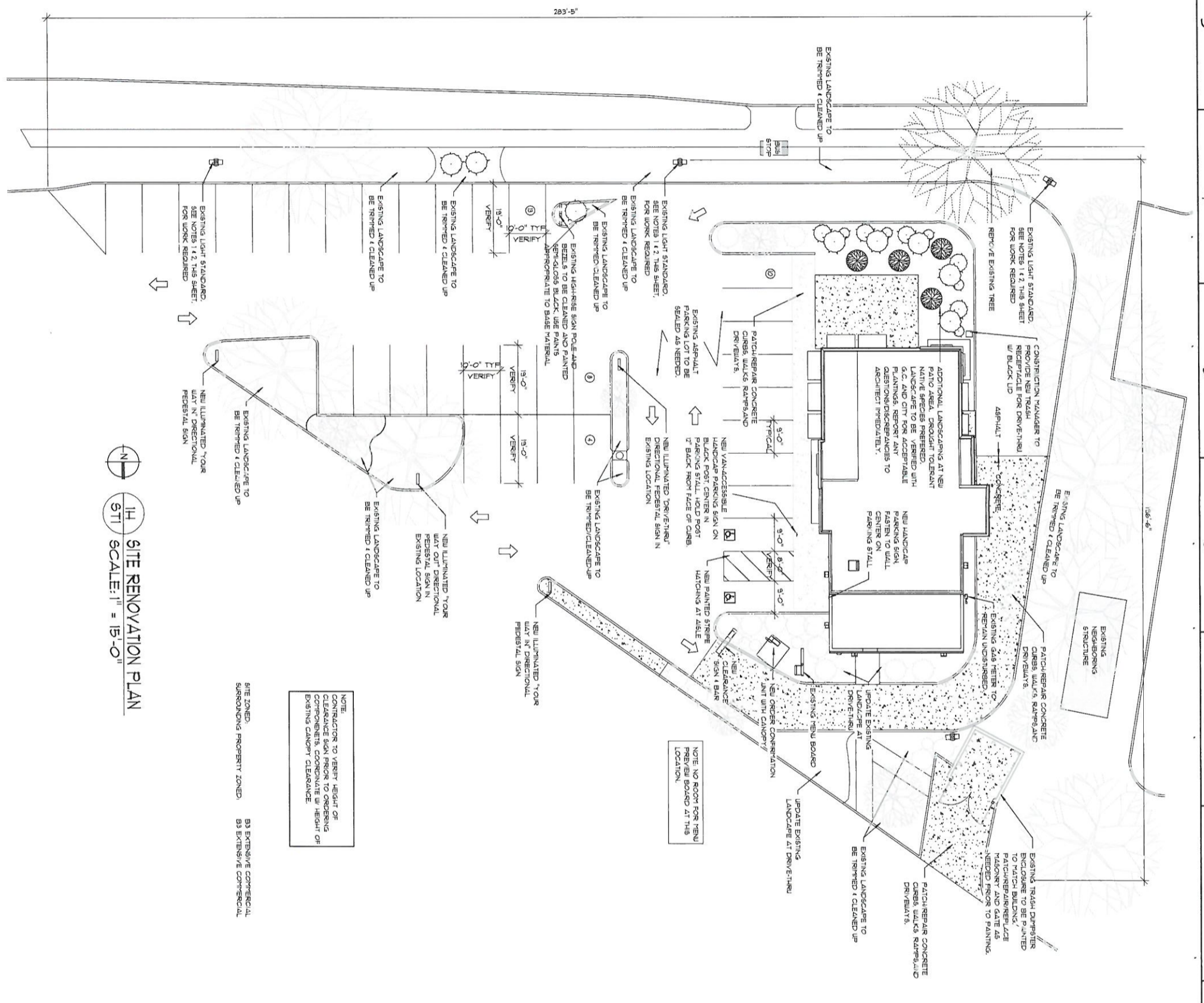

1) **SITE RENOVATION PLAN**  
SCALE: 1" = 15'-0"

NOTE:  
CONTRACTOR TO VERIFY HEIGHT OF CLEARANCE SIGN PRIOR TO ORDERING COMPONENTS. COORDINATE W/ HEIGHT OF EXISTING CANOPY CLEARANCE.

SITE ZONED: B3 EXTENSIVE COMMERCIAL  
SURROUNDING PROPERTY ZONED: B3 EXTENSIVE COMMERCIAL

- SITE CONSTRUCTION NOTES**
1. ALL EXISTING LIGHT STANDARDS SHALL BE POWER WASHED, SCRAVED, REPRIME (1) COAT AND PAINTED (2) COATS SEMI-GLOSS FINISH EXTERIOR-GRADE PAINT. COLOR TO MATCH THAT OF EXISTING LIGHT FIXTURES. ALL COATINGS TO BE COMPATIBLE WITH SUBSTRATE. REPLACE ANY DAMAGED/MISSING LAMPS, COVER PLATES, LENSES, ETC.
  2. ALL EXISTING CONCRETE FRESH (1) COAT AND PAINTED (2) COATS SEMI-GLOSS EXTERIOR-GRADE PAINT. ALL COATINGS TO BE COMPATIBLE WITH SUBSTRATE.
  3. PATCH AND REPAIR ALL ASPHALT REMOVED AT 5'x10' AREAS PRIOR TO SEAL COAT APPLICATION.
  4. REMOVE EXISTING ASPHALT PARKING LOT SHALL HAVE ALL CRACKS GAPS AND POT HOLES FILLED WITH PATCH MATERIAL. REMOVE AND REPAIR LOT SHALL RECEIVE APPROPRIATE SEAL COATING. NOTE: IF REMOVE EXISTING ASPHALT PARKING LOT IS REQUIRED TO BE OVERLAPPED, THEN EXISTING LOT IS REQUIRED TO BE OVERLAPPED.
  5. PARKING LOT SHALL BE RESTRIPPED WITH SAFETY YELLOW PAINT. TYPICAL ADA COMPLIANT BLUE TO BE USED AT HANDICAP PARKING STALLS. ALL STRIPING SHALL BE 4" MIN. WIDE.
  6. ALL NEW EXTERIOR SIGNAGE MENU BOARDS AND SIGNS TO BE PROVIDED BY OWNER. INSTALLED BY CONTRACTOR. VERIFY FOUNDATION REQUIREMENTS WITH VENDOR PRIOR TO BEGINNING EXISTING SIGN BOARD REMOVAL.
  7. EXISTING SIGN BOARD TO BE POWERWASHED, SCRAVED, REPRIME (1) COAT AND PAINTED (2) COATS SEMI-GLOSS FINISH EXTERIOR-GRADE PAINT. SEMI-GLOSS EXTERIOR GRADE PAINT. COLOR: \* FINE BLACK MEXIC VCSB-1 OR APPROVED EQUAL. ALL COATINGS TO BE COMPATIBLE WITH SUBSTRATE. REPLACE ANY DAMAGED/MISSING LAMPS, COVER PLATES, LENSES, FROSTED SIGN LENSES, ETC.
  8. EXISTING LANDSCAPING AREAS REMOVE DEAD PLANTINGS. PATCH OR REPLACE OVERSEEDING SUBSTRATES. PRUNE/REMOVE TREES. PLANT NEW GRASSES SOON IN BARE AREAS. ALL MULCHING MATERIALS TO BE REPLACED.

NO.	ISSUE/REVISION	DATE

A QUICK-SERVE RESTAURANT RENOVATION FOR:  
**BURGER KING #4671**  
3121 N. HIGHWAY 67  
FLORISSANT, MO 63033

TEWIS ARCHITECTS  
www.tewisarchitects.com  
LENEKA OFFICE:  
8725 ROSEHILL RD STE 400  
LENEKA, MO 63218  
P: 313.599.3003  
F: 313.599.3003

**bart Berneking**  
design + build  
www.bartberneking.com 636.462.5380

ARCHITECT SEAL: \_\_\_\_\_  
ENGINEER SEAL: \_\_\_\_\_



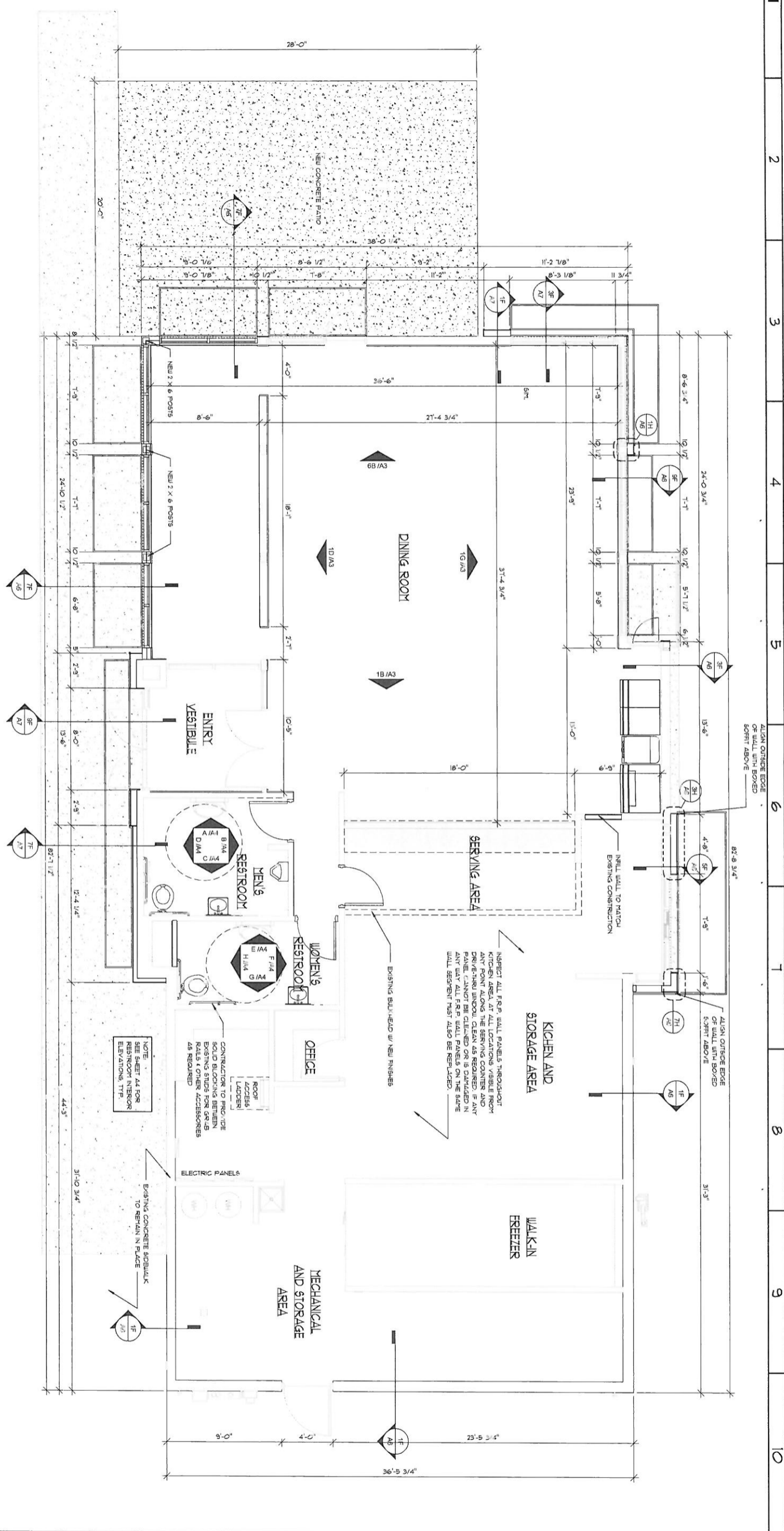

**A5 FIRST FLOOR PLAN**  
SCALE: 1/4" = 1'-0"

**NOTES:**  
 1. CONTRACTOR TO VERIFY ALL DIMENSIONS PRIOR TO BEGINNING DEMOLITION/CONSTRUCTION.  
 2. CONTRACTOR TO REPLACE ANY DAMAGED STAINED CEILING TILES THROUGHOUT STRUCTURE. REPAIR EXISTING CEILING GRID AS NEEDED.  
 3. SEE SHEET A4 FOR WINDOW & DOOR SCHEDULES.  
 4. SEE SHEET A4 FOR ALL INTERIOR ELEVATIONS AND INTERIOR FINISH SCHEDULE.  
 5. ALL INTERIOR & EXTERIOR FINISHES PROVIDED AND TO BE FINISHED BY INTERIOR FINISH COMPANY.  
 6. SEE SHEET S1 FOR ALL PARKING LOT/DRIVEWALK IMPROVEMENTS.  
 7. SEE SHEET A2 FOR INTERIOR SIGNAGE SCHEDULE.

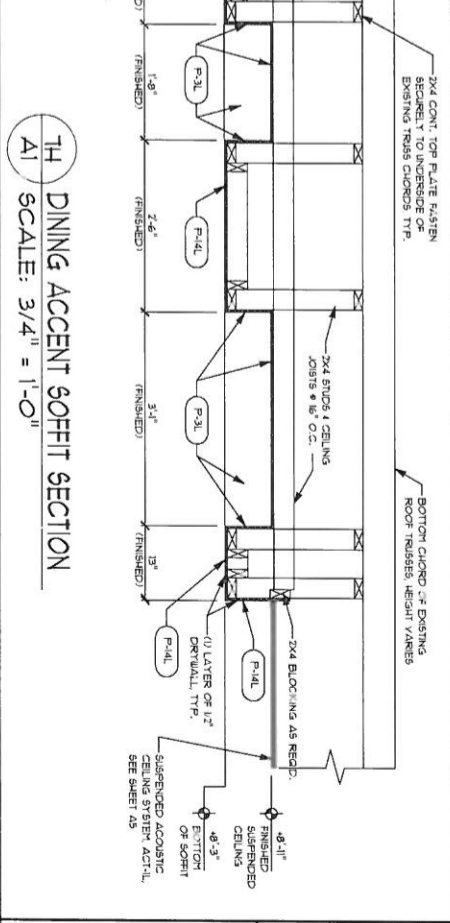
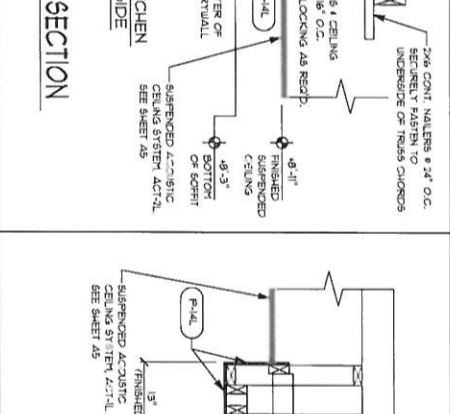
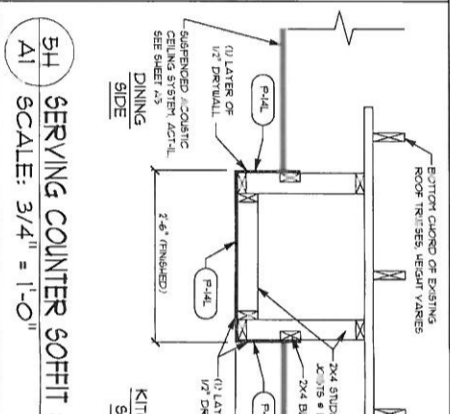
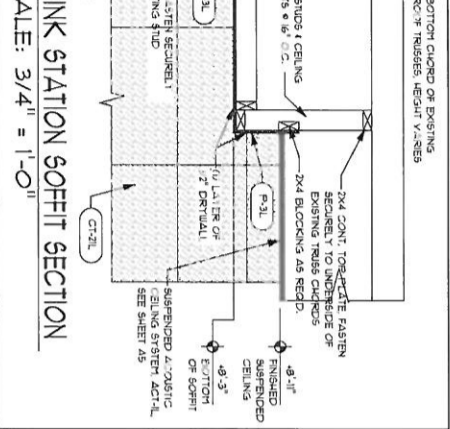
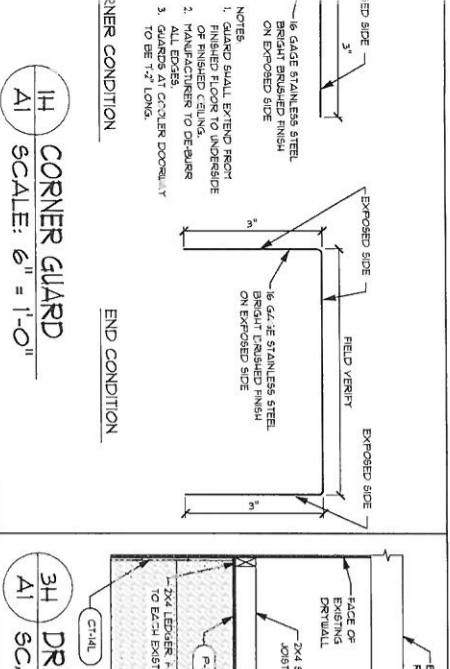

NO.	ISSUE/REVISION	DATE

A QUICK-SERVE RESTAURANT RENOVATION FOR:  
**BURGER KING #4671**  
 3121 N. HIGHWAY 67  
 FLORISSANT, MO 63033

TEVVIS ARCHITECTS  
 www.tevvisarchitects.com  
 LEXENGA OFFICE:  
 8725 ROCKHILL RD STE 400  
 LEXENGA, KS 66215  
 P: 913.599.5003  
 F: 913.599.5003

**bart beneking**  
 design + build  
 www.bartbeneking.com 636.462.5380

ARCHITECT SEAL  
 ENGINEER SEAL



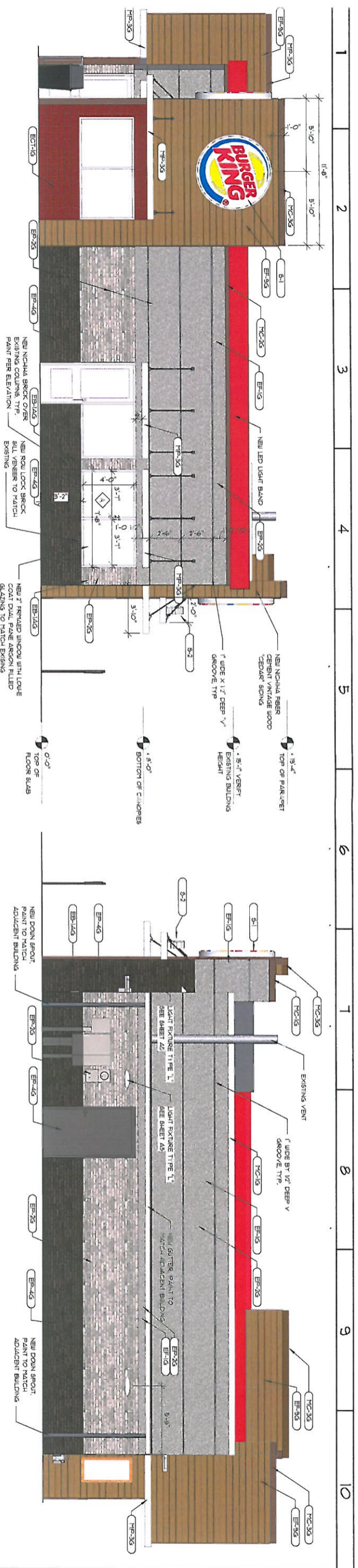

1 SOUTH ELEVATION COLOR  
A2.2 SCALE: 1/4" = 1'-0"

2 NORTH ELEVATION COLOR  
A2.2 SCALE: 1/4" = 1'-0"

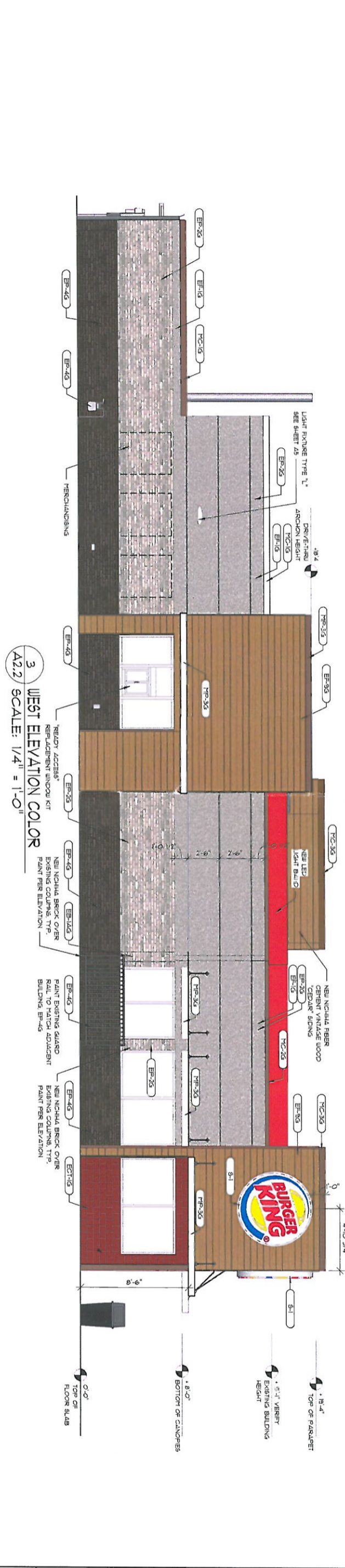

3 WEST ELEVATION COLOR  
A2.2 SCALE: 1/4" = 1'-0"



4 EAST ELEVATION COLOR  
A2.2 SCALE: 1/4" = 1'-0"

<b>TEWIS ARCHITECTS</b> www.tewisarchitects.com LENEXA OFFICE: 8725 ROSENHILL RD STE 410 LENEXA, MO 64574 P. 813.582.3003 F. 813.582.3003		<b>bart berneking</b> design + build www.bartberneking.com 636.462.5380 <small>THESE DRAWINGS ARE THE PROPERTY OF THE ARCHITECT. ANY REUSE OR REPRODUCTION OF THESE DRAWINGS WITHOUT THE WRITTEN PERMISSION OF THE ARCHITECT IS STRICTLY PROHIBITED. THE ARCHITECT ASSUMES NO LIABILITY FOR ANY DAMAGE OR INJURY TO PERSONS OR PROPERTY ARISING FROM THE USE OF THESE DRAWINGS. THE ARCHITECT'S LIABILITY IS LIMITED TO THE PROFESSIONAL SERVICES PROVIDED. ALL RIGHTS RESERVED.</small>	
A QUICK-SERVE RESTAURANT RENOVATION FOR: <b>BURGER KING #4671</b> 3121 N. HIGHWAY 67 FLORISSANT, MO 63033			
NO. ISSUE/REVISION DATE COLORED ELEVATIONS <b>A2.2</b>	JOB NO. 18-034 DATE: 01/21/19 DESIGNED BY: JLO DRAWN BY: JLO CHECKED BY: ZS-LB	ARCHITECT SEAL ENGINEER SEAL	



EXTERIOR FINISH SCHEDULE:

CODE	MATERIAL	LOCATION	MANUFACTURER	PRODUCT	COLOR	DIMENSION	ADDITIONAL NOTES
EB-1G	EXTERIOR BRICK	GENERAL	EVOLUTION BRICK	MODIGS TUMBLED (FULL BRICK)	OLDE HILLSBORO		CONTACT: GABE POWERS (502) 558-4612 NOTE: USE WITH ERG-3G
				(THIN BRICK)	SIERRA TUMBLED		
			PINE HALL BRICK	FACEBRICK	OLD IRVINGTON O/S		CONTACT: TERESA BEANE (800) 334-8609 TBEANE@PINEHALLBRICK.COM NOTE: USE WITH ERG-3G
			H.C. MUDDOX BRICK	THIN BRICK	BK WEST COAST BLEND		
EB-1AG (ALT. EB-1G)	EXTERIOR FINISH FIBER CEMENT BRICK PANELS	GENERAL	NICHHA FIBER CEMENT	NICHHA CANYON BRICK PANELS	SHALE BROWN - STAGGERED JOINTS - UNPAINTED IF NO OTHER BRICK IS PRESENT. (ON REMODELS, IF THERE IS ANY EXISTING BRICK ON THE BUILDING, THE EXISTING BRICK AND THE NICHHA BRICK MUST BE PAINTED TO MATCH EP-4G)	18" X 6'-0"	CONTACT: SANJIV MATHUR (916) 708-9306 NOTE: USE WITH ERG-3G CONTACT: NICHHA CUSTOMER SERVICE (710) 805-9466 BK@NICHHA.COM INSTALL PER MANUFACTURER'S SPECIFICATIONS VERTICAL APPLICATIONS ONLY (NOT FOR USE ON SOFFITS)
ECT-1G	EXTERIOR CERAMIC TILE	ACCENT AT BUILDING FRONT	GRANTI GIANDRE/EUROQUEST	SENSIBLE STONE ED5052	"NATURAL RED" STACKED BOND PATTERN	12" X 24"	CONTACT: JOY DETER AT EUROQUEST (714) 390-9551 OR JOY KLEIN (813) 334-3302 JKLEIN@TRANSAMERICA.COM NOTE: USE WITH EGR-4G
EP-18G	EXTERIOR CERAMIC TILE	NINE RESTAURANTS ONLY	GRANTI GIANDRE/EUROQUEST	ROVERE ANTICO LEGNI HIGH TECH	PAR 15334 "ROVERE" STACKED BOND PATTERN	6" X 36"	CONTACT: JOY DETER AT EUROQUEST (714) 390-9551 OR JOY KLEIN (813) 334-3302 JKLEIN@TRANSAMERICA.COM NOTE: USE WITH EGR-4G
EP-1G	EXTERIOR FINISH - STUCCO, STO, FIBER CEMENT SIDING PANELS	GENERAL	STO OR APPROVED EQUAL	STO POWERWALL STUCCO SYSTEM TEXTURE: FINE SAND OR STO THERM CI EFS SYSTEM	COLOR TO MATCH EP-2G PPG "TANNERS TAUPE"		CONTACT: TIM SALERNO AT STO CORP (407) 466-5371
			NICHHA FIBER CEMENT	NICHHA TUFFBLOCK	PREPAINTED TO MATCH EP-2G - PPR "TANNERS TAUPE" STACKED BOND PATTERN	18" X 6"	PERMISSIBLE ON REMODELS ONLY CONTACT: NICHHA CUSTOMER SERVICE (710) 805-9466 BK@NICHHA.COM MANUFACTURER'S SPECIFICATIONS, VERTICAL APPLICATIONS ONLY (NOT FOR USE ON SOFFITS)
EP-4G	EXTERIOR FINISH STUCCO	GENERAL	STO OR APPROVED EQUAL	STO POWERWALL STUCCO SYSTEM	COLOR TO MATCH EP-4G PPG "MONTEREY CLIFFS"		CONTACT: TIM SALERNO @ STO CORP 407-466-5371
EP-8G (ALT. TO EP-9G)	EXTERIOR FINISH STONE	EXTERIOR SIGN ARCHONS	BORAL STONE PRODUCTS	COUNTRY LEDGESTONE	"ASPEX"		CONTACT: 800-255-1711 ASHLEY.JOYCE@BORAL.COM CULTUREDSTONE@BORAL.COM
EP-9G	EXTERIOR FINISH FIBER CEMENT	EXTERIOR SIGN ARCHONS	NICHHA FIBER CEMENT	VINTAGE WOOD EF162	"CEDAR"	18" X 10"	CONTACT: NICHHA CUSTOMER SERVICE (710) 805-9466 BK@NICHHA.COM INSTALL PER MANUFACTURER'S SPECIFICATIONS, VERTICAL SEAMS SHALL BE MINIMIZED, ALL SPANS OF 10' OR MORE SHALL HAVE VERTICAL CAULKED SEAMS ALIGNED IN THE CENTER OF ARCHON. ALL TRIMS SHALL BE FACTORY PAINTED TO MATCH PANELS. VERTICAL APPLICATIONS ONLY (NOT FOR USE ON SOFFITS)
TR-1G	ALUMINUM TRIMS	EXTERIOR SIGN ARCHONS	NICHHA FIBER CEMENT	VINTAGE WOOD EF162	"CEDAR"	18" X 10"	CONTACT: NICHHA CUSTOMER SERVICE (710) 805-9466 BK@NICHHA.COM INSTALL PER MANUFACTURER'S SPECIFICATIONS, VERTICAL SEAMS SHALL BE MINIMIZED, ALL SPANS OF 10' OR MORE SHALL HAVE VERTICAL CAULKED SEAMS ALIGNED IN THE CENTER OF ARCHON. ALL TRIMS SHALL BE FACTORY PAINTED TO MATCH PANELS. VERTICAL APPLICATIONS ONLY (NOT FOR USE ON SOFFITS)
EP-2G	EXTERIOR PAINT	EXTERIOR GENERAL	PPG	PRIMER: P-921	PAINT: 6-2045X1	"TANNERS TAUPE" CUSTOM FORMULA	CONTACT: RICK GARLIN PPG CORPORATE NATIONAL ACCOUNTS MANAGER PHONE: 317-318-5800 EMAIL: GARLIN@PPG.COM NOTE: EP-4G NOT FOR USE ON ROOFS FOR REMODELING. SEE EP-4AG & EP-4BG
EP-4G	EXTERIOR PAINT	EXTERIOR WAINSCOTT		PRIMER: P-921	PAINT: 6-2045X1	"MONTEREY CLIFFS" 10Y 14/080	
EP-6G	EXTERIOR PAINT	EXTERIOR ACCENT (FOR METAL SUBSTRATES ONLY)		PRIMER: 6-712	PAINT: 6-130	"BURGER KING SILVER" CUSTOM FORMULA	
EP-6AG	EXTERIOR PAINT	EXISTING MANSARD ROOFS, SHINGLES, & BARREL TILE		PRIMER: P-921	PAINT: 90-110	"GRIMMY'S GREY" COGN 20/000	NOTE: FOR REMODELS ONLY
EP-4BG	EXTERIOR PAINT	EXISTING STANDING SEAM METAL ROOF		PRIMER: P-712	PAINT: 90-110	"MARCH WIND" CUSTOM FORMULA	NOTE: FOR REMODELS ONLY
EP-8BG	EXTERIOR PAINT	METAL COPING AT ARCHON TOWERS		PRIMER: P-921	PAINT: 6-2045X1	"CEDAR" CUSTOM FORMULA	
E-T-G	EXTERIOR PAINT	POLES & SIGNS		PRIMER: 90-112	PAINT: 90-353	"BLACK"	
EGR-3G	GROUT	BRICK		MAPEI		"#5 'CHAMOIS'"	NOTE: USE WITH EB-1G
EGR-4G	GROUT	CERAMIC TILE	CUSTOM BUILDING PRODUCTS	POLYBLEND SANDED	"#35 'WINTER GRAY'"	NOTE: USE WITH ECT-1G FOR SETTING MATERIALS USE COMPLETE CONTACT RAPID SET SEAL GROUT WITH AQUAMIX SEALERS CHOICE GOLD	
EGR-9G	GROUT	NINE RESTAURANTS ONLY CERAMIC TILE	LATICRETE	POLYBLEND SANDED	"#6 'CHESTNUT BROWN'"	NOTE: USE WITH ECT-18G CONTRACTOR TO ALLOW 1/16" MAX FOR GROUT JOINT FOR SETTING MATERIALS USE COMPLETE CONTACT RAPID SET SEAL GROUT WITH AQUAMIX SEALERS CHOICE GOLD CONTACT: KIRBY DAVIS AT LATICRETE 203-671-7210	
MC-1G	METAL COPING	TOP OF LIGHT BAND, WALL CAP	W.P. HICKMAN SYSTEMS, INC.	PERMA SNAP PLUS	A-30 "SILVERSMITH"		CONTACT: W.P. HICKMAN COMPANY 828-616-1100 WWW.WPH.COM
MC-2G	METAL COPING	BELOW LIGHT BAND		PERMA SNAP PLUS	FACTORY FINISH TO MATCH EP-2G PPG "TANNERS TAUPE" TO BE PAINTED TO MATCH EP-8G PPG "CEDAR"		
MC-3G	METAL COPING	TOP OF ARCHON		PERMA SNAP PLUS			
MP-1G	METAL COPING	PARAPET LIGHT BAND	LEKTRON SEE APPROVED SIGN SUPPLIERS	LED LIGHT BAND			SEE PLANS PRODUCT INFORMATION: JOHN FITZILSON AT LEKTRON (400) 634-4099 OR (98) 622-4978 EXT 302 EMAIL: J.FITZILSON@LEKTRON.COM
MP-3G	METAL CANOPY	ABOVE DOORS & WINDOWS	SEE APPROVED CANOPY SUPPLIERS	CUSTOM METAL CANOPY	COLOR: CLEAR ANODIZED		SEE PLANS
MP-4G	METAL WINING/SSM ROOFING	ABOVE WINDOWS / MANSARD ROOFING	FIRESTONE METAL PRODUCTS	STANDING SEAM METAL ROOF UC-4 PROFILE	SILVER METALLIC SR		CONTACT: YUSUKE KOREEDA (615) 945-9991 Email: koreedyusuke@firestonecorp.com
			BERRIDGE ROOFING METAL PRODUCTS	STANDING SEAM METAL ROOF CEE-LOCK	PREMIUM METALLIC - ZINC COTE		CONTACT: (710) 650-1041

NOTE:  
ALL EXISTING DARK BRONZE  
COLOR STOREFRONT DOOR AND  
WINDOW UNITS TO REMAIN IN PLACE.

SIGNAGE SCHEDULE:

NOTE:  
ENTIRE ROOF TO RECEIVE NEW SELF-  
ADHERING MEMBRANE ROOFING,  
VERIFY ACTUAL REQUIREMENTS W/  
ROOFING CONTRACTOR (NOT SHOWN).

MARK	DESCRIPTION	LOCATION	NOTES
S-1	MEDALLION, 6" DIAMETER	ARCHONS, EAST & SOUTH SIDES	NEW
S-2	TEXT: FLAME GRILLING SINCE 1994	ARCHON BY MAIN ENTRY	NEW

NOTE:  
SEE LIGHTING FIXTURE SCHEDULE  
ON SHEET AS FOR LIGHTING, TYP.

WINDOW SCHEDULE:

READ ELEVATIONS AND PLAN FOR TOTAL WINDOW AND FRAME SIZES.

WINDOW	FRAME SIZE	FRAME MATERIAL	GLAZING	MAX. U-FACTOR	NOTES
A	2'	ALUMINUM	TRANSPARENT	38	DUEL PANEL LOW-E ARGON FILLED

# CITY OF FLORISSANT

## Public Hearing



In accordance with 405.310 of the Florissant Zoning Code a Public Hearing will be held by the City Council of Florissant, MO. in the Council Chambers, 955 rue St. Francois, on Tuesday, February 28, 2017 at 7:30 p.m. on the following proposition:

To authorize a Special Use Permit to STL Howdershell, LLC d/b/a St. Louis Fish & Chicken to allow for a carry-out restaurant for the property located at 340-A Howdershell Road (legal description to govern). Citizens will have an opportunity to be heard. Anyone with special needs should contact the City Clerk at least 5 days before said public hearing by calling 839-7630 or TDD 839-5142.

CITY OF FLORISSANT, Karen Goodwin, City Clerk

Posted  
2-15-17  
①

FLORISSANT PLANNING & ZONING COMMISSION APPLICATION

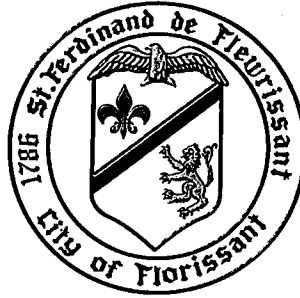

City Of Florissant – Public Works  
314-839-7648

Application is hereby made to the Building Commissioner of the Department of Public works Office at the City of Florissant, Missouri, to appear before the Planning & Zoning Commission

Please Print or Type The Following Information

Property Address: 340A Howdershell Rd

Property Owners Name: Family Video Movie Club Phone #: \_\_\_\_\_

Property Owners Address: 450 Howdershell Rd Florissant MO 63031

Business Owners Name: STC Howdershell LLC Phone #: 314-898-3002

Business Owners Address: 340A Howdershell Rd Florissant mo 63031

DBA (Doing Business As) St Louis Fish & Chicken.

Authorized Agents Name: Mecath Salameh CO. Name: \_\_\_\_\_  
(Authorized Agent to Appear Before The Commission) meh.

Agents Address: 7111 N. Hanly Rd - Hazelwood Phone #: 63042 314-484-7113

Request Fast Food take out Restaurant.

State complete request (print or type only).

IF A TRAFFIC STUDY IS REQUIRED FOR CERTAIN DEVELOPMENTS AND USES THE COST OF THE TRAFFIC STUDY SHALL BE PAID BY THE APPLICANT. PLEASE SUBMIT FOLDED PLANS

Applicant's Signature \_\_\_\_\_

Date

1/23/17

Received by: CA Receipt # 83803 OFFICE USE ONLY Amount Paid: 12500 Date: 1/23/17

STAFF REMARKS: \_\_\_\_\_

DATE APPLICATION REVIEWED: \_\_\_\_\_

SIGNATURE OF STAFF WHO REVIEWED APPLICATION \_\_\_\_\_

COMMISSION ACTION TAKEN:

RECOMMENDED APPROVAL  
PLANNING & ZONING  
CHAIRMAN

SIGN.

DATE: 2/6/17

SPECIAL USE PERMIT APPLICATION  
TO THE CITY OF FLORISSANT  
PLANNING AND ZONING COMMISSION



City Of Florissant – Public Works  
314-839-7648

PLANNING & ZONING ACTION  
RECOMMENDED APPROVAL  
PLANNING & ZONING  
CHAIRMAN

Council Ward 3 Zoning \_\_\_\_\_

Initial Date Petitioner Filed \_\_\_\_\_  
Building Commissioner to complete  
ward, zone & date filed

SIGN. [Signature] DATE: 2/6/17

SPECIAL PERMIT FOR To operate a take-out Restaurant  
Statement of what permit is being sought. (i.e., special permit for operation of a restaurant.)

AMEND SPECIAL PERMIT #- \_\_\_\_\_ TO ALLOW FOR \_\_\_\_\_  
ordinance # Statement of what the amendment is for.

LOCATION 340A Howdershell Rd Florissant MO 63031  
Address of property.

1) Comes Now STL Howdershell LLC dba St Louis Fish & Chicken  
Enter name of petitioner. If a corporation, state as such. If applicable include DBA (Doing Business As)

and states to the Planning and Zoning Commission that he (she) (they) has (have) the following legal interest in the tract of land located in the City of Florissant, State of Missouri, as described on page 3 of this petition.

Legal interest in the Property) lease  
State legal interest in the property. (i.e., owner of property, lease.  
Submit copy of deed or lease or letter of authorization from owner to seek a special use.

2) The petitioner(s) further state(s) that the property herein described is presently being used for Vacant and that the deed restrictions for the property do not prohibit the use which would be authorized by said Permit.

3) The petitioner(s) further states (s) that they (he) (she) are submitting a detailed site plan of the proposed or existing development showing location and use of all structures, off-street parking, and all other information required by the Zoning Ordinance or determined necessary by the Building Commissioner.

4) The petitioner(s) further state(s) that (he) (she) (they) can comply with all of the requirements of the City of Florissant, including setback lines and off- street parking.

- 5) The petitioner (s) further (represent (s) and warrants (s) that they (he) (she) has (have) not made any arrangement to pay any commission gratuity or consideration, directly or indirectly to any official, employee or appointee of the City of Florissant, with respect to this application.
- 6) The petitioner(s) further state (s) that the Special Use Permit is sought for the following purposes, and no other, List in detail, all activities sought to be covered by the permit (i.e.; operation of a business, approval of building and / or site plans (preliminary and / or final), plan approval for sign, etc.):
- 7) The petitioner (s) state (s) the following factors and reason to justify the permit:  
(If more space is needed, separate sheets ~~maybe attached~~)

Eyad Afaneh  
 PRINT NAME                      SIGNATURE

FOR STL Howdershell PDC  
 (company, corporation, partnership)

Print and sign application. If applicant is a corporation or partnership signature must be a CORPORATE OFFICER or a PARTNER. NOTE: Corporate officer is an individual named in corporate papers.

- 8) I (we) hereby certify that (indicate one of the following):
  - (X) I (we) have a legal interest in the herein above described property.
  - ( ) I am (we are) the duly appointed agent(s) of the petitioner (s), and that all information given here is true and a statement of fact.

Petitioner may assign an agent to present petition to the Commission and Council. The agent must sign the petition in below, and provide address and telephone number

SIGNATURE \_\_\_\_\_

ADDRESS \_\_\_\_\_  
 STREET                      CITY                      STATE                      ZIP CODE

TELEPHONE NUMBER \_\_\_\_\_  
 BUSINESS

I (we) the petitioner (s) do hereby appoint Muath Salameh as  
 my (our) duly authorized agent to represent me (us) in regard to this petition.  
Print name of agent.

[Signature]  
 Petitioner or authorized agent's signature

**NOTE:** When the petitioner and/or his duly authorized agent appears before the Planning and Zoning Commission and to make a presentation, the same individuals must also appear before the City Council at the Public Hearing to make the presentation and no one else will be permitted to make the presentation to the City Council.

IF DESCRIPTIONS OF PLATS OR SURVEYS ARE INCORRECT, OR IF THE PETITION FORM IS NOT CORRECTLY AND COMPLETELY FILLED OUT, IT WILL BE RETURNED FOR ADDITIONS OR CORRECTIONS AND WILL HAVE TO BE RE-SUBMITTED.



## REQUIRED INFORMATION

Please mark an "X" in the appropriate type of operation then fill in applicable section (a), (b) or (c). Corporations are to submit copy of Missouri corporate papers with registration papers.

1) Type of Operation:

Individual \_\_\_\_\_ Partnership \_\_\_\_\_ Corporation   X  

(a) If an individual:

- (1) Name and Address \_\_\_\_\_
- (2) Telephone Number \_\_\_\_\_
- (3) Business Address \_\_\_\_\_
- (4) Date started in business \_\_\_\_\_
- (5) Name in which business is operated if different from (1) \_\_\_\_\_
- (6) If operating under a fictitious name, provide the name and date registered with the State of Missouri, and a copy of the registration.

(b) If a partnership:

- (1) Names & addresses of all partners \_\_\_\_\_
- (2) Telephone numbers \_\_\_\_\_
- (3) Business address \_\_\_\_\_
- (4) Name under which business is operated \_\_\_\_\_
- (5) If operating under fictitious name, provide date the name was registered with the State of Missouri, and a copy of the registration.

(c) If a corporation:

- (1) Names & addresses of all partners   Eyad Alanch 2182 Encino dr 63031
- (2) Telephone numbers   314-898-3002
- (3) Business address   340A Howdershell Rd Florissant mo 63031
- (4) State of Incorporation & a photocopy of incorporation papers   MO
- (5) Date of Incorporation   1/18/2017
- (6) Missouri Corporate Number   LC001521956
- (7) If operating under fictitious name, provide the name and date registered with the State of Missouri, and a copy of registration.   St Louis Fish & Chicken - 1/23/17
- (8) Name in which business is operated   St. Louis Fish & Chicken.
- (9) Copy of latest Missouri Anti-Trust. (annual registration of corporate officers) If the property location is in a strip center, give dimensions of your space under square footage and do not give landscaping Information.

Please fill in applicable information requested. If the property is located in a strip center, give the dimensions of your space under square footage and do not give landscaping information.

Name St. Louis Fish & Chicken  
Address 340A Howdershell Rd Florissant MO 63031  
Property Owner Family Video Movie Club, Inc  
Location of property 350 Howdershell Rd. Florissant mo 63031  
Dimensions of property \_\_\_\_\_  
Property is presently zoned Retail Requests Rezoning To Restaurant  
Proposed Use of Property Restaurant  
Type of Sign \_\_\_\_\_ Height \_\_\_\_\_  
Type of Construction \_\_\_\_\_ Number Of Stories 1  
Square Footage of Building \_\_\_\_\_ Number of Curb Cuts \_\_\_\_\_  
Number of Parking Spaces 18 Sidewalk Length \_\_\_\_\_  
Landscaping: No. of Trees \_\_\_\_\_ Diameter \_\_\_\_\_  
No. of Shrubs \_\_\_\_\_ Size \_\_\_\_\_  
Fence: Type \_\_\_\_\_ Length \_\_\_\_\_ Height \_\_\_\_\_

**PLEASE SUBMIT THE FOLLOWING:**

1. Plan or drawing showing zoning of adjoining properties.
2. Plan or drawing showing location of property in relation to major streets and all adjoining properties.
3. Drawing showing measurement of tract and overall area of tract.
4. Plan or drawing showing proposed parking layout, landscaping, parking lighting and trash enclosure.
5. If Special Permit is for a sign show location of sign on plot plan.

**PROVIDE LEGAL DESCRIPTION OF PROPERTY PERTAINING TO THIS PETITION**

(Close legal description with acreage to the nearest tenth of an acre).

Provide a legal description of the property. If part of a shopping center list address and state part of what shopping center (i.e.: 351 N. Highway 67 part of Florissant Meadows Shopping Center). If property is a single lot, list full written legal description with bearings and distances.

340A Howdershell Rd Part of Family Video Shopping Center Located at 350 Howdershell Rd.

**PROVIDE LOCATION MAP SHOWING AREA INVOLVING THIS PETITION**

Provide a drawing of a location map showing the nearest major intersection.

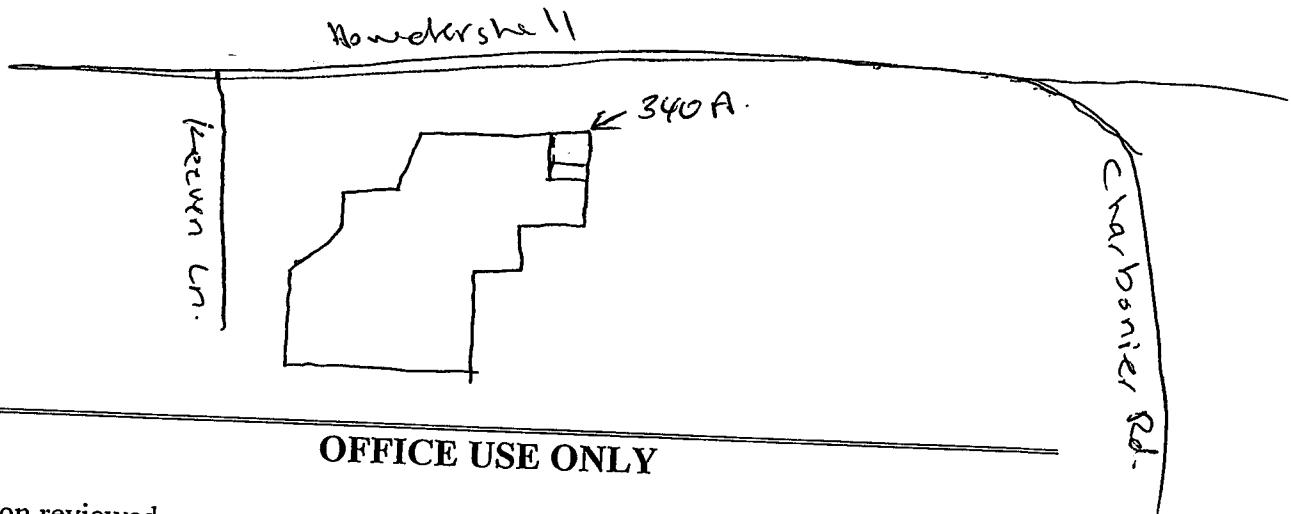

**OFFICE USE ONLY**

Date Application reviewed \_\_\_\_\_

STAFF REMARKS: \_\_\_\_\_

\_\_\_\_\_

\_\_\_\_\_

\_\_\_\_\_

\_\_\_\_\_  
Building Commissioner or Staff Signature

# Google Maps 350 Howdershell Rd

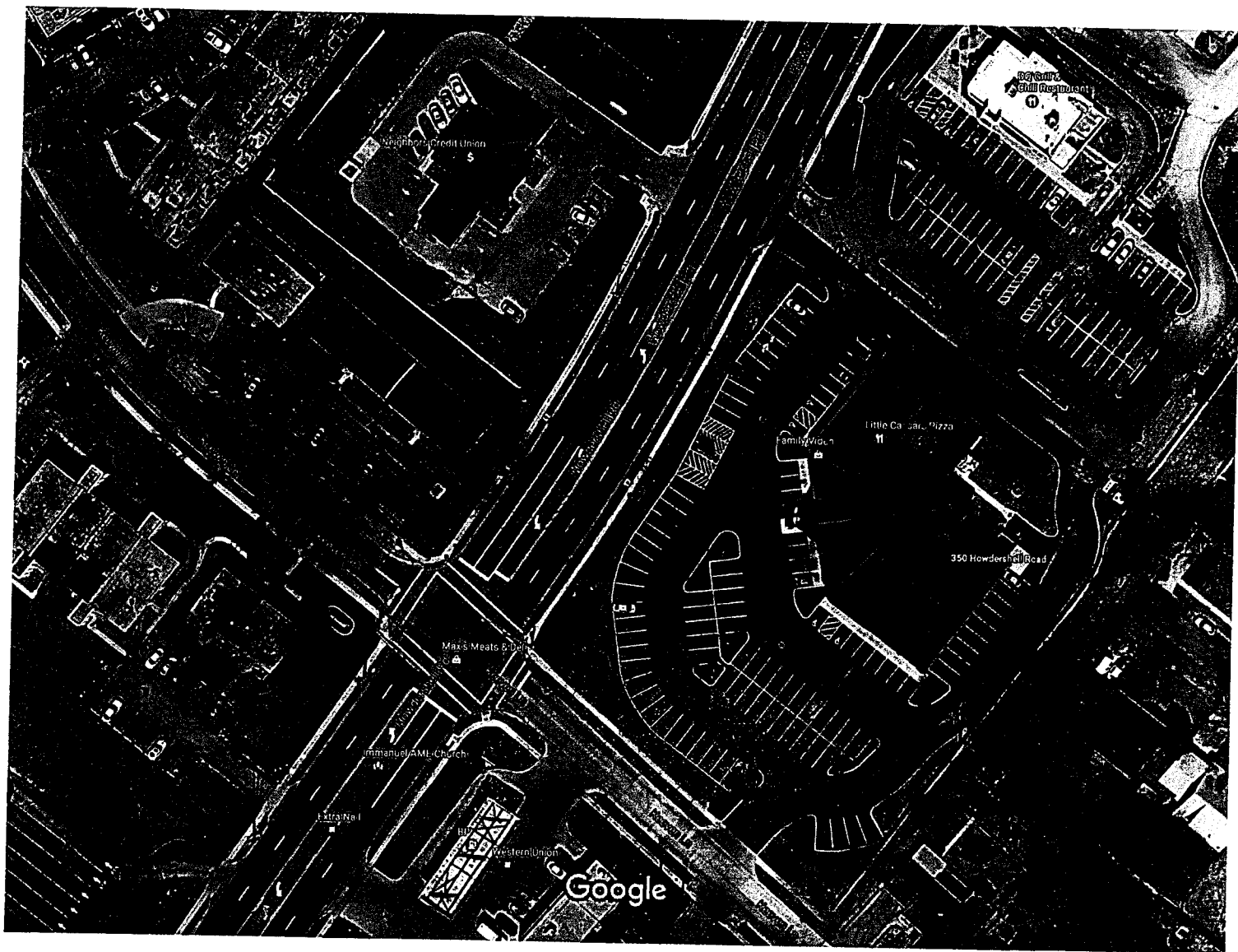

Imagery ©2017 Google, Map data ©2017 Google 50 ft

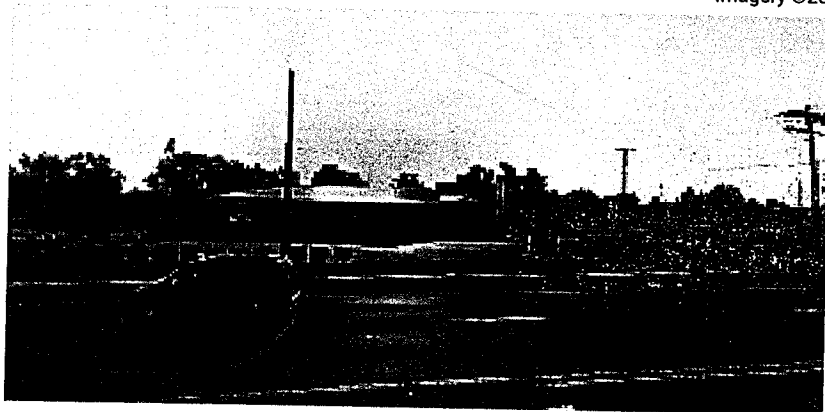

**350 Howdershell Rd**  
 Florissant, MO 63031

1

**MEMORANDUM**

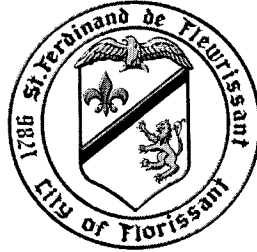

2

**CITY OF FLORISSANT**

3

*"Preserve and improve the health, safety, and welfare of our residents, businesses and the general public in the City of Florissant; while at the same time maintaining property values and improving the quality of life in the City of Florissant."*

4

5

6

To: Planning and Zoning Commissioners Date: January 31, 2017

7

8

From: Philip E. Lum, AIA-Building Commissioner cc: Louis B. Jearls, Jr.- P.E., PWLF  
Director of Public Works  
Applicant  
File

9

10

11

12

13

Subject: Request recommended approval for a Special Use to allow for a carry-out restaurant at 340-A Howdershell, in an existing 'B-5' Zoning District.

14

15

16

17

**STAFF REPORT**  
**CASE NUMBER PZ-020617-2**

18

19

20

**I. PROJECT DESCRIPTION:**

21

22

This is a request for recommended approval for a Special Use to allow for a carry-out restaurant at **340-A Howdershell, (St. Louis Fish and Chicken Grill)** in an existing 'B-5' Zoning District.

23

24

25

26

**II. EXISTING SITE CONDITIONS:**

27

28

The property at 350 Howdershell has approximately 13,000 square feet of retail masonry structure with metal roof, which is currently occupied by Family Video and Little Caesar's and 340-A was formerly a carry-out Steak restaurant. The facility at 340-A has 1300 square feet currently vacant. Family Video is the primary tenant, occupying over 7000 square feet.

29

30

31

32

33

The site has a landscaped and paved parking lot with 104 parking spaces.

34

35

The 'B-5' District allows carry-out restaurants by Special Use if granted by the City Council.

36

37

38

39

40

41  
42  
43  
44  
45  
46  
47  
48  
49  
50  
51  
52  
53  
54  
55  
56  
57  
58  
59  
60  
61  
62  
63  
64  
65  
66  
67  
68  
69  
70  
71  
72  
73  
74  
75  
76  
77  
78  
79  
80  
81  
82  
83  
84  
85  
86

**III. SURROUNDING PROPERTIES:**

The property to the west across Howdershell is the JFK Recreation Center, the property to the North is a Dairy Queen in a 'B-5' District; the property to the East has 3 residences 2025 and 2030 Bobbinray and 2315 Keeven, all in an 'R-4' District; and the property to the south across Keeven Lane is a filling station and convenience store 420 Howdershell and a retail center at 428 Howdershell in a 'B-3' District.

**IV. STAFF ANALYSIS:**

1. The application is accompanied by a professional plans, dated 1/25/17, prepared by Deru & Associates, LLC which includes drawing CS and A1.0.
2. The applicant has not stated hours of operation.
3. There are no signs presented, therefore signs must comply with Chapter 520 of the City Code.
4. The required parking when the building is fully used and fully occupied is calculated per 405.225 per the following:
  - a. Restaurants less than 1500 s.f.  $4.5/1000 \text{ s.f.} = 5$  per carryout restaurant.
  - b. Retail Space at  $4/1000 \text{ s.f.} = 4 \times 13.2 = 52$
  - c. Therefore, there is an excess of parking spaces existing.

**VI. STAFF SUGGESTED MOTION:**

**Suggested Motion for 140-A Howdershell (St. Louis Fish and Chicken Grill):**

I move to recommend approval for a Special Use for ~~140-A~~ **140-A Howdershell** to allow for a carry-out restaurant in a 'B-5' Extensive Business District, as depicted on the application documents: CS and A1.0 dated 1/25/17 as prepared by by Deru & Associates, LLC, subject to the regulations in the 'B-5' "Planned Commercial Development District", and the following additional requirements:

**1. GENERAL DEVELOPMENT CONDITIONS.**

- a. Unless, and except to the extent, otherwise specifically, development shall be effected only in accordance with all ordinances of the City of Florissant.

**2. PROJECT COMPLETION.**

Construction shall start within 90 days of the issuance of building permits for the project and shall be developed in accordance of the approved final development plan within 180 days of start of construction.

(End of report and suggested motion 1/31/17)

**General Requirements:**

These specifications and the accompanying drawings constitutes the furnishing of all labor, materials and equipment required to complete the installation of the systems as shown including all accessories, fittings, auxiliaries, and components required for the proper performance of the systems.

Work installed shall be in strict compliance with applicable 2009 IBC other state and local codes.

Governing codes and regulations. Contractors shall visit the site prior to bidding. Bids shall serve as evidence of knowledge of existing conditions. Field verify all existing equipment and working conditions.

Furnish all labor, materials, equipment, and tools to perform carpentry work shown, noted or scheduled for a complete and finished installation.

All materials and equipment shall be commercial grade and shall carry a U.L. label.

Materials, products and equipment, including components thereof shall be new and such as appears on the Underwriter's Laboratory list of approved items and shall meet the requirements of recognized standards.

Interior walls shall be framed and secured to the exterior brick walls. Wood studing shall be 16" O.C. for permit and partition walls.

All exterior framed walls shall have insulated with R-19 6" thick installed between each stud.

All exterior framed walls shall stop at the bottom of the roof joist. There will no ceiling installed for the sales floor, office hall or storage room.

The restroom shall have a lay-in ceiling grid system install complete.

The word "provide" as used herein means to furnish and install complete.

Glazing must meet the IBC 2009 section 2406.3 item 1 code tempered glass required

Secure and pay for all required permits and inspection certificates.

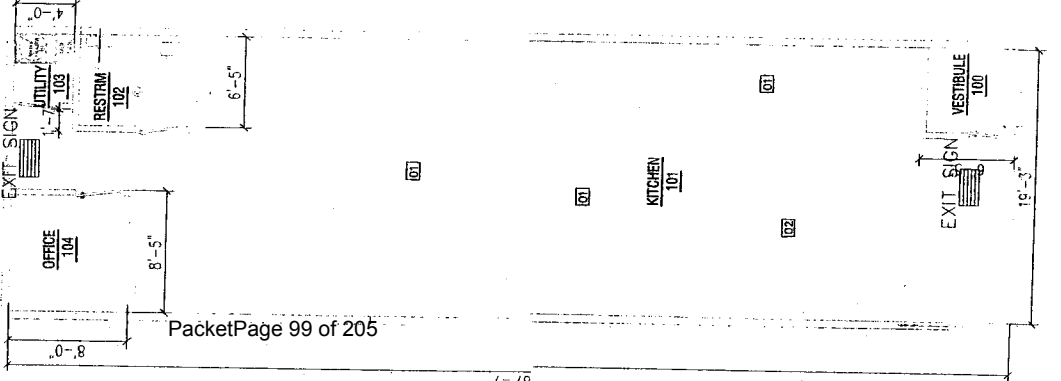
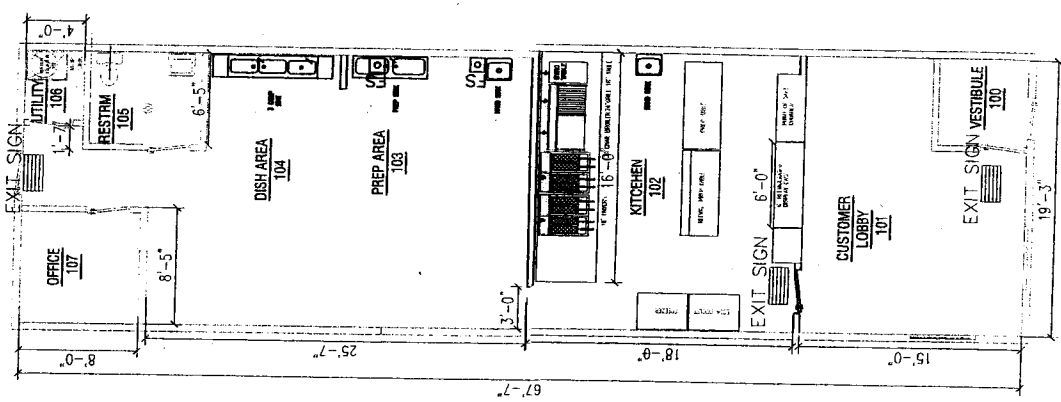

- KEYED NOTES:**
- GENERAL REQUIREMENT NOTES**
- 01.01 13.00 SPECIAL CONSTRUCTION NOTES
  - 02.01 14.00 CONVEYING NOTES
  - 03.01 21.00 FIRE SUPPRESSION NOTES
  - 04.01 22.00 PLUMBING NOTES
  - 05.01 22.02 ACCESSIBLE WATERCLOSET
  - 06.01 22.06 FLOOR SINK
  - 07.01 22.07 WATER HEATER
  - 08.01 23.01 FURNACE
  - 09.01 23.02 CONDENSING UNIT
  - 10.01 23.03 TOILET EXHAUST FAN
  - 11.01 25.00 INTEGRATED NOTES
  - 12.01 26.00 ELECTRICAL NOTES
  - 13.01 27.00 COMMUNICATION NOTES
  - 14.01 28.00 ELECTRICAL SAFETY AND SECURITY NOTES
  - 15.01 31.00 EARTHWORK
  - 16.01 32.00 EXTERIOR IMPROVEMENT NOTES
- GENERAL REQUIREMENT NOTES**
- 01.01 02.00 EXISTING WINDOW / STOREFRONT SYSTEM TO REMAIN.
  - 02.01 03.00 CONCRETE WORK NOTES
  - 03.01 04.00 MASONRY WORK NOTES
  - 04.01 05.00 METAL WORK NOTES
  - 05.01 06.02 METAL STUD FRAMING 16 O.C. AND 3'-0" O.C. AND 7" MIN. Ø
  - 06.01 07.00 MASONRY AND COMPOSITE NOTES
  - 07.01 08.02 METAL STUD FRAMING 16 O.C.
  - 08.01 09.00 THERMAL AND MOISTURE PROTECTION NOTES
  - 09.01 10.03 CONTINUOUS SEALANT
  - 10.01 11.01 SCHEDULING DOORS AND WINDOW NOTES
  - 11.01 12.02 METAL HOLLOW FRAME PAINTED
  - 12.01 13.00 ALUMINUM THRESHOLD SET IN BED OF SEALANT
  - 13.01 14.00 FINISHES NOTES
  - 14.01 15.00 FINISHES NOTES
  - 15.01 16.01 GYPSUM PARTITION
  - 16.01 17.00 GYPSUM BOTH SIDES TYPICAL
  - 17.01 18.03 VINYL BASE SEE FINISH SCHEDULE
  - 18.01 19.00 TOILET PARTITION DISPENSER
  - 19.01 20.05 38" GRAB BAR
  - 20.01 21.07 18" GRAB BAR
  - 21.01 22.00 EQUIPMENT NOTES
  - 22.01 23.00 FURNISHING NOTES
  - 23.01 24.00

**FLOOR PLAN**  
 3/16" = 1'

**DEMO PLAN**  
 3/16" = 1'

- FLOOR PLAN GENERAL NOTES**
1. CEILING GRID TO REMAIN
  2. INSTALL NEW VCT TILE OVER EXISTING FLOOR.
  3. PAINT EXISTING CEILING GRID BEFORE PUTTING IN NEW TILES
  4. INSTALL NEW NON-ABSORBENT, WASHABLE CEILING TILES
  5. ALL WALLS SHALL BE FINISHED UNLESS OTHERWISE NOTED
  6. VERIFY THE WALL CONSTRUCTION TYPE IN THE AREA WHERE THE NEW KITCHEN EXHAUST HOOD IS TO BE INSTALLED. IF IT IS NOT A METAL STUD WALL BUILD A SECOND PARTITION WALL IN FRONT OF THE EXISTING WALL CONSTRUCTED OF Z2GA, 3-5/8 STUDS AND DRYWALL THAT EXTEND 18" PAST THE EXHAUST HOOD BOTH ENDS. THIS SHALL BE FIRE TAPED PRIOR TO STAINLESS STEEL BEING INSTALLED.
- FLOOR PLAN KEYED NOTES**
- 01 CLEAN FLOOR PRIOR TO INSTALLING NEW FLOOR TILE
  - 02 FRAME UP WALLS FOR NEW WALLS WITH Z2GA, 3-5/8" METAL STUDS.
  - 03 INSTALL 1/2" DRYWALL ON NEWLY FRAMED WALLS AND EXISTING OPEN WALLS AT ALL WALL SEAMS AFTER INSPECTION.
  - 04 PAINT ALL WALLS AFTER THE TAPING INSPECTION.
  - 05 INSTALL NEW FLOORING AND COVE BASE AFTER THE PAINTING HAS BEEN COMPLETED.
  - 06 PAINT EXISTING CEILING GRID.
  - 07 INSTALL NEW 2X4 NON-ABSORBENT CEILING TILE IN KITCHEN AND DISH AREA.
  - 08 INSTALL NEW STANDARD 2X4 CEILING TILE IN KITCHEN AND DISH AREA.
  - 09 INSTALL NEW 35" PRE-HUNG, ENTRY DOOR WITH A STANDARD KEYED LOCK.
  - 10

- DEMOLITION GENERAL NOTES**
1. EXISTING CEILING GRID TO REMAIN
  2. EXISTING UNDERGROUND PLUMBING TO REMAIN
  3. NO CHANGES TO EXISTING RESTROOM AND MOP CLOSET.
  4. ALL WALLS SHALL BE P1 UNLESS OTHERWISE NOTED
- DEMOLITION KEYED NOTES**
1. REMOVE ALL CARPET
  2. REMOVE EXISTING CEILING TILE IN NEW KITCHEN AREA

RECOMMENDED APPROVAL  
 PLANNING & ZONING  
 CHAIRMAN

SIGN: *[Signature]* DATE: 2/14/17

PERMIT SET  
 FOR CONSTRUCTION

1 INTRODUCED BY COUNCILMAN SCHILDROTH  
2 JANUARY 23, 2017

3  
4 BILL NO. 9256

ORDINANCE NO.

5  
6 **ORDINANCE TO AUTHORIZE AN AMENDMENT TO SPECIAL USE**  
7 **PERMIT NO. 7398 TO ALLOW FOR EXTERIOR ALTERATIONS FOR**  
8 **THE PROPERTY LOCATED AT 1261 GRAHAM ROAD.**  
9

10 WHEREAS, the Florissant Zoning Ordinance authorizes the City Council of the City of  
11 Florissant, by Special Use Permit, after public hearing thereon, to permit the location and  
12 operation of a restaurant; and

13 WHEREAS, the Florissant City Council has heretofore granted a Special Use Permit to  
14 Starbuck Corporation d/b/a Starbucks for the location and operation of a restaurant on the  
15 property described in Ordinance No. 7398; and

16 WHEREAS, an application has been filed by Starbucks Corporation for an amendment  
17 to the said Special Use Permit heretofore granted under Ordinance No. 7398 to authorize the  
18 addition of certain conditions; and

19 WHEREAS, the Planning and Zoning Commission of the City of Florissant at their  
20 meeting of January 3, 2017 has recommended that the said Special Use Permit be amended; and

21 WHEREAS, due notice of public hearing no. 17-01-003 on said application to be held on  
22 the 23rd day of January, 2017 at 7:30 P.M. by the Council of the City of Florissant was duly  
23 published, held and concluded; and

24 WHEREAS, the Council, following said public hearing, and after due and careful  
25 consideration, has concluded that the granting of an amendment to the Special Use Permit  
26 authorized by Ordinance No. 7398, as hereinafter provided would be in the best interest of the  
27 City of Florissant.

28 NOW, THEREFORE, BE IT ORDAINED BY THE COUNCIL OF THE CITY OF  
29 FLORISSANT, ST. LOUIS COUNTY, MISSOURI, AS FOLLOWS:  
30

31 Section 1: The Special Use Permit heretofore granted to Starbucks  
32 Corporation under Ordinance No. 7398 in a B-3 Zoning District is hereby amended to  
33 allow a remodeling of the exterior, according to the proposal prepared by the petitioner as  
34 described in related documents presented and according to the attached drawings as  
35 prepared by Starbucks Coffee Company and dated 12/14/16. Approval is subject to the



36 regulations of these ordinances of the City of Florissant, and the following additional  
37 requirements:

38 1. GENERAL DEVELOPMENT CONDITIONS.

39 a. Unless, and except to the extent, otherwise specifically provided, in  
40 Ord No. 7398, development shall be effected only in accordance with  
41 all ordinances of the City of Florissant.

42 2. PROJECT COMPLETION.

43 a. Construction shall start within 90 days of the issuance of building  
44 permits for the project and shall be developed in accordance of the  
45 approved final development plan within 180 days of start of  
46 construction.  
47

48 Section 2: Said Special Permit shall be conditioned on and shall remain in full force and  
49 effect so long as the conditions set out in Ordinance no. 7398, as now amended, are adhered to.

50 Section 3: This ordinance shall become in force and effect immediately upon its passage  
51 and approval.

52  
53 Adopted this \_\_\_\_ day of \_\_\_\_\_, 2017.

54  
55  
56 \_\_\_\_\_  
57 Jackie Pagano  
58 President of the Council  
59 City of Florissant  
60

61  
62 Approved this \_\_\_\_ day of \_\_\_\_\_, 2012.

63  
64  
65 \_\_\_\_\_  
66 Thomas P. Schneider  
67 Mayor, City of Florissant  
68

69 ATTEST:

70  
71  
72 \_\_\_\_\_  
73 Karen Goodwin, MMC/MRCC  
74 City Clerk

# **CITY OF FLORISSANT**

## **Public Hearing**



**In accordance with 405.310 of the Florissant Zoning Code a Public Hearing will be held by the City Council of Florissant, MO. in the Council Chambers, 955 Rue St. Francois, on Monday, January 23, 2017 at 7:30 P.M. on the following proposition:**

**To authorize an amendment to Special Use Permit No. 7398, to allow for exterior alterations for the property located at 1261 Graham Road (legal description to govern). Citizens will have an opportunity to be heard. Anyone with special needs should contact the City Clerk at least 5 days before said public hearing by calling 839-7630 or TDD 839-5142.**

**CITY OF FLORISSANT, Karen Goodwin, MMC City Clerk**

FLORISSANT PLANNING & ZONING COMMISSION APPLICATION

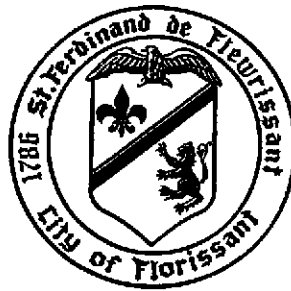

City Of Florissant – Public Works 314-839-7648

"Preserve and improve the health, safety, and welfare of our residents, businesses and the general public in the City of Florissant; while at the same time maintaining property values and improving the quality of life in the City of Florissant."

Application is hereby made to the Building Commissioner, Department of Public Works at the City of Florissant, Missouri, to appear before the Planning & Zoning Commission.

Please Print neatly or Type the Following Information:

Property Address: 1261 Graham Rd, Florissant MO 63031

Property Owners Name: Sherman Partners LLC Phone/email: 615-366-1098/cvaughn@cherryandassociates.com

Property Owners Address: 505 Westview Ave, Nashville TN 37205

Business Owners Name: Starbucks Corporation Phone/email: 206-318-1575

Business Owners Address: 2401 Utah Ave South, MS Stop: S-SD 10, Seattle WA 98134

DBA (Doing Business As) Starbucks

Authorized Agents Name: Richard Avery, acting on behalf of Lee Weintraub Co. Name: Zimmerman Weintraub Associates LLC (Authorized Agent to Appear Before The Commission)

Agents Address: 813 W Randolph St, Chicago IL 60607 Phone/email: 312-879-9636 x205

Request Amendment to existing Special Use Permit 7398 - alterations to a sit-down, drive-through, carry-out coffee shop

Proposed changes to improve overall appearance of building include: exterior paint color change, cladding material change, signage update, and parapet-height change to hide existing RTUs.

State complete request (print or type only).

IF A TRAFFIC STUDY IS REQUIRED FOR CERTAIN DEVELOPMENTS AND USES THE COST OF THE TRAFFIC STUDY SHALL BE PAID BY THE APPLICANT. PLEASE SUBMIT FOLDED PLANS

[Signature] Applicant's Signature

15 Dec. 2016 Date

Received by: [Signature] Receipt # 597877 OFFICE USE ONLY Amount Paid: 125 Date: 12/20/16

STAFF REMARKS:

COMMISSION ACTION TAKEN:

DATE APPLICATION REVIEWED:

SIGNATURE OF STAFF WHO REVIEWED APPLICATION

Planning & Zoning Application Page 1 of 1 - Revised 7/15/15

PacketPage 103 of 205

RECOMMENDED APPROVAL PLANNING & ZONING CHAIRMAN

SIGN. [Signature] DATE: 1/3/2017

**SPECIAL USE PERMIT APPLICATION  
TO THE CITY OF FLORISSANT  
PLANNING AND ZONING COMMISSION**

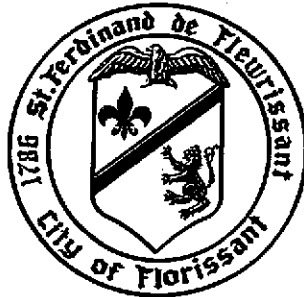

**City Of Florissant – Public Works  
314-839-7648**

*"Preserve and improve the health, safety, and welfare of our residents, businesses and the general public in the City of Florissant; while at the same time maintaining property values and improving the quality of life in the City of Florissant."*

**PLANNING & ZONING ACTION**

Council Ward 5 Zoning B-3

**RECOMMENDED APPROVAL**  
PLANNING & ZONING  
CHAIRMAN

Initial Date Petitioner Filed \_\_\_\_\_  
Building Commissioner to complete  
ward, zone & date filed

*[Signature]* DATE: 1/3/2017

SPECIAL PERMIT FOR operation of a sit-down, carry-out and drive-through coffee house with food

Statement of what permit is being sought. (i.e., special permit for operation of a restaurant).

AMEND SPECIAL PERMIT # 7398 TO ALLOW FOR finish changes to masonry paint, cladding material and parapet height  
ordinance # \_\_\_\_\_ Statement of what the amendment is for.

LOCATION 1261 Graham Rd, Florissant MO 63031

Address of property.

1) Comes Now Starbucks Corporation

Enter name of petitioner. If a corporation, state as such. If applicable include DBA (Doing Business As)

and states to the Planning and Zoning Commission that he (she) (they) has (have) the following legal interest in the tract of land located in the City of Florissant, State of Missouri, as described on page 3 of this petition.

Legal interest in the Property) Lease

State legal interest in the property. (i.e., owner of property, lease).  
Submit copy of deed or lease or letter of authorization from owner to seek a special use.

2) The petitioner(s) further state(s) that the property herein described is presently being used for operation of a sit-down, carry-out and drive-through coffee house with food and that the deed restrictions for the property do not prohibit the use which would be authorized by said Permit.

3) The petitioner(s) further states (s) that they (he) (she) are submitting a detailed site plan of the proposed or existing development showing location and use of all structures, off-street parking, and all other information required by the Zoning Ordinance or determined necessary by the Building Commissioner.

- 4) The petitioner(s) further state(s) that (he) (she) (they) shall comply with all of the requirements of the City of Florissant, including setback lines and off- street parking.
- 5) The petitioner (s) further (represent (s) and warrants (s) that they (he) (she) has (have) not made any arrangement to pay any commission gratuity or consideration, directly or indirectly to any official, employee or appointee of the City of Florissant, with respect to this application.
- 6) The petitioner(s) further state (s) that the Special Use Permit is sought for the following purposes, and no other, as listed in detail, all activities sought to be covered by the permit (i.e.; operation of a business, approval of building and/or site plans (preliminary and / or final), plan approval for signage, etc.):
- 7) The petitioner (s) state (s) the following factors and reason to justify the permit:  
(If more space is needed, separate sheets maybe attached)

Lee Weintraub / 312-879-9636/lweintraub@zwalink.com  
 PRINT NAME SIGNATURE email and phone  
 FOR Zimmerman Weintraub Associates LLC acting on behalf of Starbucks Corporation  
 (company, corporation, partnership)

Print and sign application. If applicant is a corporation or partnership signature must be a CORPORATE OFFICER or a PARTNER. NOTE: Corporate officer is an individual named in corporate papers.

8) I (we) hereby certify that, as applicant (circle one of the following):

1. I (we) have a legal interest in the herein above described property.

2. I am (we are) the duly appointed agent(s) of the petitioner (s), and that all information given here is true and a statement of fact.

Permission granted by the Petitioner assigning an agent (i.e. Architect) to present this petition in their behalf, to the Commission and/or Council. The petitioner must sign below, and provide contact information:

PRESENTOR SIGNATURE Richard Avery Digitally signed by Richard Avery  
 Date: 2016.12.15 12:24:52 -06'00'  
 ADDRESS 813 W Randolph St, Chicago IL 60607  
 STREET CITY STATE ZIP CODE  
 TELEPHONE / EMAIL 312-879-9636 x205 / ravery@zwalink.com  
 BUSINESS

I (we) the petitioner (s) do hereby appoint Zimmerman Weintraub Associates as  
 Print name of agent.  
 my (our) duly authorized agent to represent me (us) in regard to this petition.

  
 Signature of Petitioner authorizing an agent

**NOTE:** When the petitioner and/or his duly authorized agent appears before the Planning and Zoning Commission and to make a presentation, the same individuals must also appear before the City Council at the Public Hearing to make the presentation and no one else will be permitted to make the presentation to the City Council without authorized approval.

IF DESCRIPTIONS, PLATS OR SURVEYS ARE INACCURATE, OR IF THE PETITION APPLICATION IS NOT CORRECT OR COMPLETE, IT WILL BE RETURNED FOR ADDITIONS OR CORRECTIONS.

## REQUIRED INFORMATION

Please mark an "X" in the appropriate type of operation, then fill in applicable section (a), (b) or (c).  
Corporations are to submit copy of Missouri corporate papers with registration papers.

1) Type of Operation: Individual \_\_\_\_\_ Partnership \_\_\_\_\_ Corporation  X

(a) If an individual:

(1) Name and Address \_\_\_\_\_

(2) Telephone Number \_\_\_\_\_

(3) Business Address \_\_\_\_\_

(4) Date started in business \_\_\_\_\_

(5) Name in which business is operated if different from (1) \_\_\_\_\_

(6) If operating under a fictitious name, provide the name and date registered with the State of Missouri, and a copy of the registration.

(b) If a partnership:

(1) Names & addresses of all partners \_\_\_\_\_

(2) Telephone numbers \_\_\_\_\_

(3) Business address \_\_\_\_\_

(4) Name under which business is operated \_\_\_\_\_

(5) If operating under fictitious name, provide date the name was registered with the State of Missouri, and a copy of the registration.

(c) If a corporation:

(1) Names & addresses of all partners  Please see attached Annual Registration Report

(2) Telephone numbers  Please see attached Annual Registration Report

(3) Business address  221 Bolivar Street, Jefferson City MO 65101

(4) State of Incorporation & a photocopy of incorporation papers  Missouri

(5) Date of Incorporation  Please see attached Annual Registration Report

(6) Missouri Corporate Number  Please see attached Annual Registration Report

(7) If operating under fictitious name, provide the name and date registered with the State of Missouri, and a copy of registration. \_\_\_\_\_

(8) Name in which business is operated  Starbucks

(9) Copy of latest Missouri Anti-Trust. (annual registration of corporate officers) If the property location is in a strip center, give dimensions of your space under square footage and do not give landscaping Information.

Please fill in applicable information requested. If the property is located in a shopping center, provide the dimensions of the tenant space under square footage and landscaping information may not be required.

Name Starbucks

Address 1261 Graham Rd, Florissant MO 63031

Property Owner Sherman Partners LLC

Location of property West side of Graham Rd just east of Dunn Rd.

Dimensions of property 265'x154' per existing site plan

Property is presently zoned B3 Requests Rezoning To \_\_\_\_\_

Proposed Use of Property operation of a sit-down, carry-out and drive-through coffee house with food

Type of Sign updated signs on existing footings Height \_\_\_\_\_

Type of Construction IIB Number Of Stories 1

Square Footage of Building 3354 Number of Curb Cuts 2

Number of Parking Spaces 56 existing to remain Sidewalk Length 163'

Landscaping: No. of Trees existing to remain Diameter \_\_\_\_\_

No. of Shrubs \_\_\_\_\_ Size \_\_\_\_\_

Fence: Type N/A Length \_\_\_\_\_ Height \_\_\_\_\_

**PLEASE SUBMIT THE FOLLOWING INFORMATION ON PLANS OR DRAWINGS:**

1. Zoning of adjoining properties.
2. Show location of property in relation to major streets and all adjoining properties.
3. Show measurement of tract and overall area of tract.
4. Proposed parking layout and count, parking lighting.
5. Landscaping and trash screening.
5. Location, sizes and elevations of signage.

**PROVIDE LEGAL DESCRIPTION OF PROPERTY PERTAINING TO THIS PETITION**

(Close legal description with acreage to the nearest tenth of an acre).

**Provide a legal description of the property. If part of a shopping center, list address and show part of what shopping center (i.e.: 351 N. Highway 67 part of Florissant Meadows Shopping Center). If property is a single lot, list full written legal description with metes and bounds bearings and dimensions.**

PLEASE SEE ATTACHED  
LEGAL DESCRIPTION, p.60

**PROVIDE LOCATION MAP SHOWING AREA INVOLVING THIS PETITION**  
Provide a drawing of a location map showing the nearest major intersection.

PLEASE SEE ATTACHED  
LOCATION MAP, p.61

---

---

**OFFICE USE ONLY**

Date Application reviewed \_\_\_\_\_

STAFF REMARKS: \_\_\_\_\_

\_\_\_\_\_

\_\_\_\_\_

\_\_\_\_\_

---

**Building Commissioner or Staff Signature**



1 INTRODUCED BY COUNCILMAN SCHILDROTH  
2 APRIL 23, 2007

3  
4  
5 BILL NO. 8311

ORDINANCE NO. 7398

6  
7 AN ORDINANCE GRANTING A SPECIAL USE PERMIT TO  
8 STARBUCKS COFFEE COMPANY D/B/A STARBUCK'S TO ALLOW  
9 FOR THE OPERATION OF A SIT-DOWN, CARRY-OUT AND DRIVE-  
10 THROUGH COFFEE HOUSE WITH FOOD FOR THE PROPERTY  
11 LOCATED AT 1261 GRAHAM ROAD.

12  
13 WHEREAS, the Florissant Zoning Ordinance authorizes the City Council of the City of  
14 Florissant, by Special Use Permit, after public hearing thereon, to permit the operation of a  
15 coffee house; and

16 WHEREAS, an application has been filed by Starbucks Coffee Company for the  
17 operation of a sit-down, carry-out and drive-through coffee house with food located at 1261  
18 Graham Road; and

19 WHEREAS, the Planning and Zoning Commission of the City of Florissant, at their  
20 meeting of April 2<sup>nd</sup>, 2007 has recommended that the said Special Use Permit be granted with  
21 certain conditions; and

22 WHEREAS, due notice of a public hearing on said application to be held on the April 23,  
23 2007 at 8:00 P.M. by the Council of the City of Florissant was duly published, held and  
24 concluded; and

25 WHEREAS, the Council, following said public hearing, and after due and careful  
26 consideration, has concluded that the granting of the Special Use Permit as hereinafter provided  
27 would be in the best interest of the City of Florissant.

28 NOW, THEREFORE, BE IT ORDAINED BY THE COUNCIL OF THE CITY OF  
29 FLORISSANT, ST. LOUIS COUNTY, MISSOURI, AS FOLLOWS:

30  
31 Section 1: A Special Use Permit is hereby granted to Starbucks Coffee Company d/b/a  
32 Starbuck's and renovations of the property shall be in accordance with the plans submitted and  
33 dated 1/25/07:

34 Section 2: Said Permit herein authorized shall remain in full force and effect and subject  
35 to all of the ordinances of the City of Florissant.

36 Section 3: When the named permittee discontinues the operation of said business, the  
37 Special Use Permit herein granted shall no longer be in force and effect.

38 Section 4: This ordinance shall become in force and effect immediately upon its passage  
39 and approval.

40

41 Adopted this 14 day of May, 2007.

42

43

44

45

46

47

48

49

50

51

52

53

54

55

56

57

58

59

60

61

62

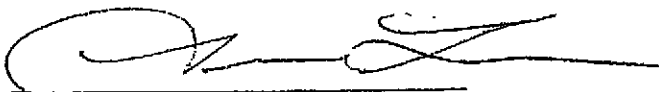

Tim Lee  
President of the Council  
City of Florissant

Approved this 15 day of May, 2007.

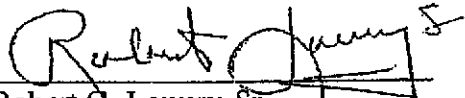

Robert G. Lowery, Sr.  
Mayor, City of Florissant

ATTEST:

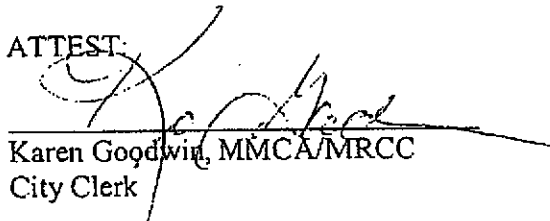
  
Karen Goodwin, MMCA/MRCC  
City Clerk



**SIGNAGE SCHEDULE**

NO.	DESCRIPTION	QUANTITY	UNIT	PRICE	TOTAL
1	STARBUCKS COFFEE SIGNAGE	1	SQ. FT.	1000.00	1000.00
2	STARBUCKS COFFEE SIGNAGE	1	SQ. FT.	1000.00	1000.00
3	STARBUCKS COFFEE SIGNAGE	1	SQ. FT.	1000.00	1000.00
4	STARBUCKS COFFEE SIGNAGE	1	SQ. FT.	1000.00	1000.00
5	STARBUCKS COFFEE SIGNAGE	1	SQ. FT.	1000.00	1000.00
6	STARBUCKS COFFEE SIGNAGE	1	SQ. FT.	1000.00	1000.00
7	STARBUCKS COFFEE SIGNAGE	1	SQ. FT.	1000.00	1000.00
8	STARBUCKS COFFEE SIGNAGE	1	SQ. FT.	1000.00	1000.00
9	STARBUCKS COFFEE SIGNAGE	1	SQ. FT.	1000.00	1000.00
10	STARBUCKS COFFEE SIGNAGE	1	SQ. FT.	1000.00	1000.00

**NOTES:**

1. ALL SIGNAGE SHALL BE INSTALLED IN ACCORDANCE WITH THE CITY OF ST. LOUIS SIGNAGE ORDINANCES AND THE CITY OF ST. LOUIS SIGNAGE DEPARTMENT'S SIGNAGE MANUAL.

2. THE CONTRACTOR SHALL BE RESPONSIBLE FOR OBTAINING ALL NECESSARY PERMITS AND APPROVALS FROM THE CITY OF ST. LOUIS SIGNAGE DEPARTMENT.

3. THE CONTRACTOR SHALL BE RESPONSIBLE FOR THE PROTECTION OF ALL EXISTING UTILITIES AND STRUCTURES.

4. THE CONTRACTOR SHALL BE RESPONSIBLE FOR THE PROTECTION OF ALL EXISTING SIGNAGE.

5. THE CONTRACTOR SHALL BE RESPONSIBLE FOR THE PROTECTION OF ALL EXISTING CURBS AND SIDEWALKS.

6. THE CONTRACTOR SHALL BE RESPONSIBLE FOR THE PROTECTION OF ALL EXISTING TREES AND PLANTS.

7. THE CONTRACTOR SHALL BE RESPONSIBLE FOR THE PROTECTION OF ALL EXISTING UTILITIES AND STRUCTURES.

8. THE CONTRACTOR SHALL BE RESPONSIBLE FOR THE PROTECTION OF ALL EXISTING SIGNAGE.

9. THE CONTRACTOR SHALL BE RESPONSIBLE FOR THE PROTECTION OF ALL EXISTING CURBS AND SIDEWALKS.

10. THE CONTRACTOR SHALL BE RESPONSIBLE FOR THE PROTECTION OF ALL EXISTING TREES AND PLANTS.

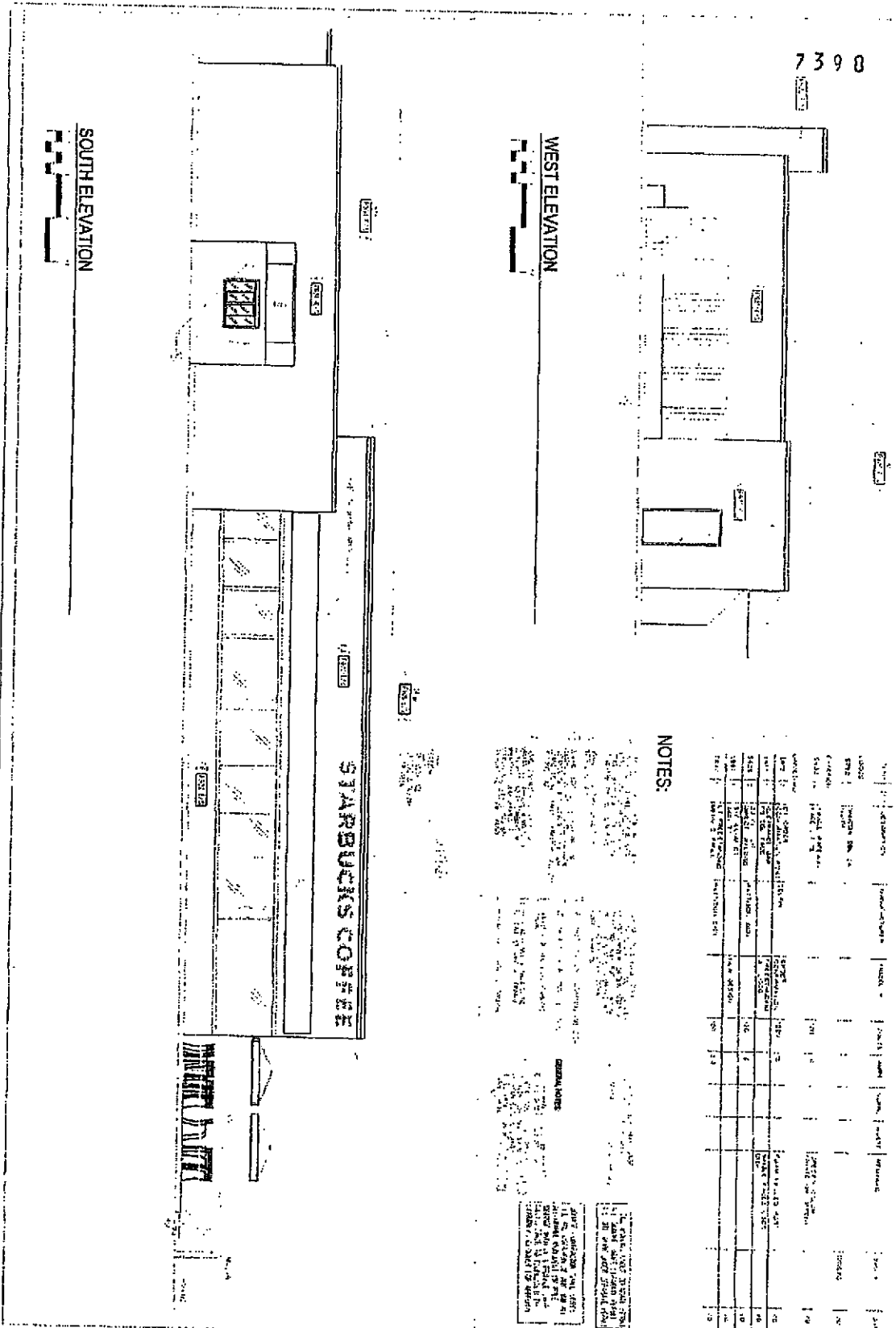

**STARBUCKS COFFEE COMPANY**

PROJECT: **STARBUCKS COFFEE**  
**GRAHAM & I-270**  
 1261 GRAHAM ROAD  
 FLORISSANT, MD 63031  
 ST LOUIS

DATE: 12/11/11  
 DRAWN BY: J. B. BROWN  
 CHECKED BY: J. B. BROWN  
 APPROVED BY: J. B. BROWN

SCALE: 1/8" = 1'-0"  
 SHEET NUMBER: **A1.1R**

**STARBUCKS COFFEE COMPANY**  
 12000 OLIVE BLDG SUITE 100  
 ST. LOUIS, MO 63141  
 314.438.2300

**STREETLINE**  
**EXTERIOR**  
**ELEVATIONS**

STONE # 15511  
 PROJECT # 38175C-011  
 CONCEPT: STARBUCKS COFFEE  
 CLIENT: STARBUCKS COFFEE COMPANY  
 DATE: 12/11/11  
 DRAWN BY: J. B. BROWN  
 CHECKED BY: J. B. BROWN  
 APPROVED BY: J. B. BROWN

NOTES:

STARBUCKS  
COFFEE COMPANY  
1401 W. HANNA, SUITE  
1000  
ST. LOUIS, MO 63104

ARCHITECT OF RECORD  
ARCHITECT  
1801 OLIVE ROAD, SUITE 200  
ST. LOUIS, MO 63108

REV DATE BY DESCRIPTION

STARBUCKS COFFEE  
GRAHAM & I-270  
1261 GRAHAM ROAD  
FLORISSANT, MO 63031  
ST LOUIS

PROJECT NO. 13511  
PROJECT NAME STARBUCKS COFFEE  
DRAWN BY: [Name]  
CHECKED BY: [Name]  
DATE: [Date]  
SCALE: AS SHOWN  
DESIGNED BY: [Name]  
DATE: [Date]  
DRAWN BY: [Name]  
CHECKED BY: [Name]  
DATE: [Date]

SHEET TITLE  
CIVIL SITE PLAN  
SCALE: 1/8" = 1'-0"  
DO NOT SCALE DIMENSIONS  
SHEET NUMBER  
C1.0

NO.	DATE	BY	DESCRIPTION
1	12/15/00	[Name]	PRELIMINARY
2	01/10/01	[Name]	REVISED PER COMMENTS
3	02/05/01	[Name]	REVISED PER COMMENTS
4	03/05/01	[Name]	REVISED PER COMMENTS
5	04/05/01	[Name]	REVISED PER COMMENTS
6	05/05/01	[Name]	REVISED PER COMMENTS
7	06/05/01	[Name]	REVISED PER COMMENTS
8	07/05/01	[Name]	REVISED PER COMMENTS
9	08/05/01	[Name]	REVISED PER COMMENTS
10	09/05/01	[Name]	REVISED PER COMMENTS
11	10/05/01	[Name]	REVISED PER COMMENTS
12	11/05/01	[Name]	REVISED PER COMMENTS



SITE PLAN

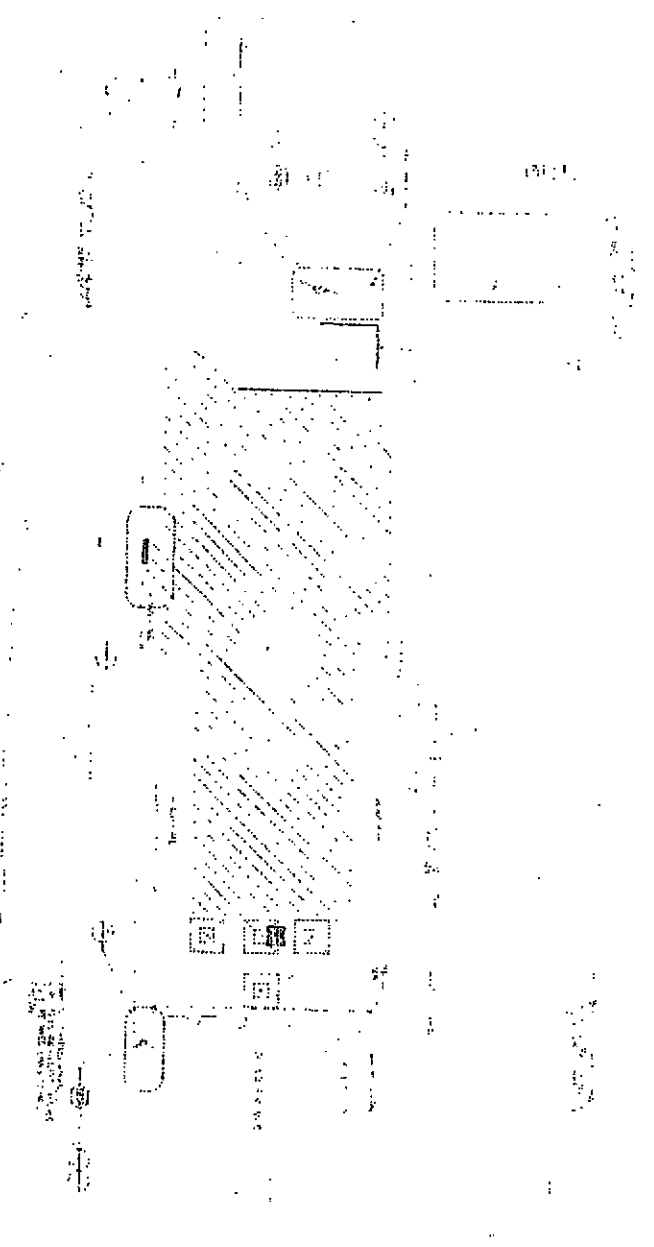

2198

PLANT SCHEDULE:



QTY	1
DESCRIPTION	1" DBH. SP. 10'



QTY	1
DESCRIPTION	1" DBH. SP. 10'

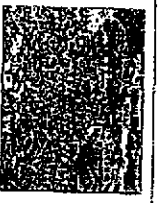

QTY	1
DESCRIPTION	1" DBH. SP. 10'

QTY	1
DESCRIPTION	1" DBH. SP. 10'

LANDSCAPING PLAN



Include trees with  
10' DBH.

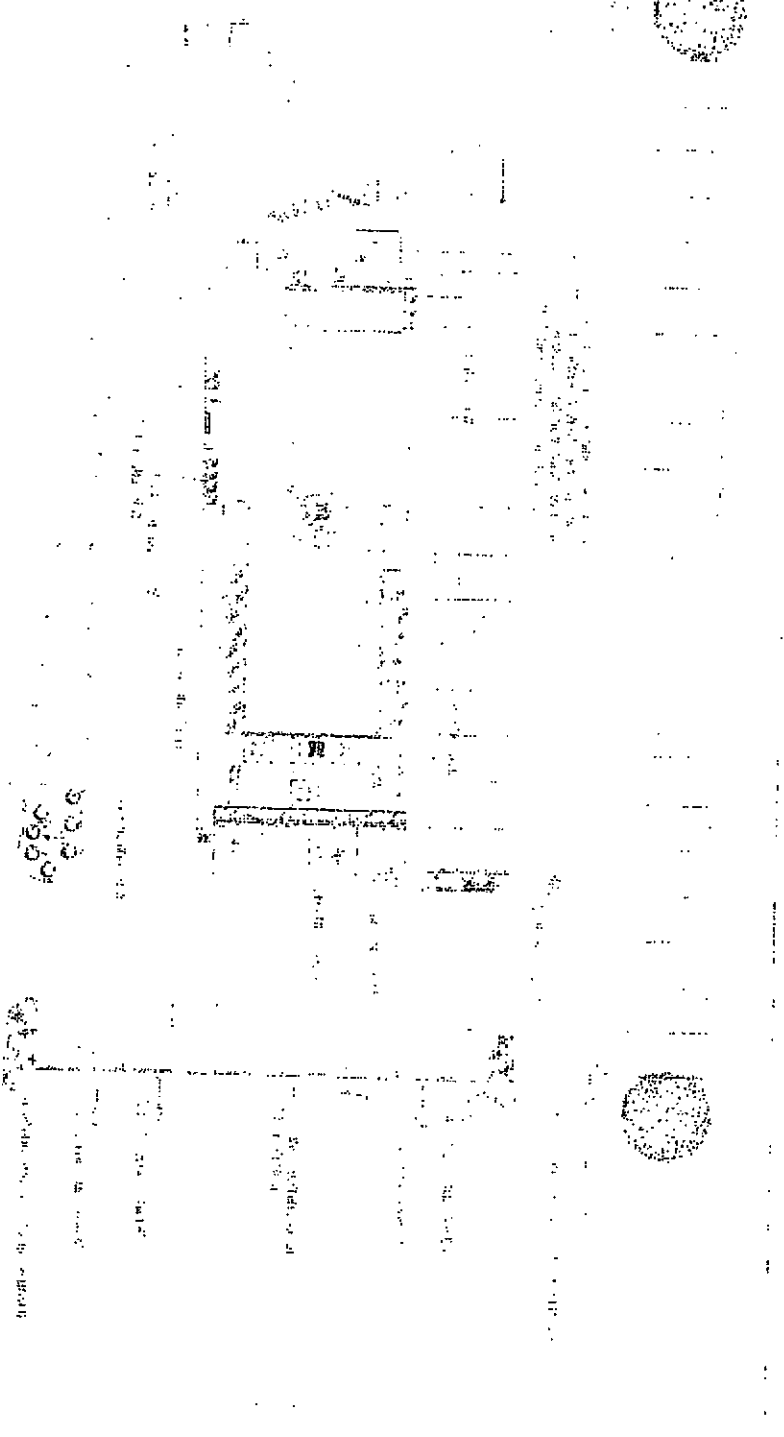

SHEET TITLE <b>LANDSCAPING PLAN</b>	PROJECT: <b>STARBUCKS COFFEE</b> <b>GRAHAM &amp; I-270</b> 1261 GRAHAM ROAD FLORISSANT, MO 63031 ST LOUIS	SHEET NUMBER <b>11.0</b>	SCALE AS SHOWN ON DRAWING	DATE 08/11/11	DRAWN BY J. B. BROWN	CHECKED BY J. B. BROWN	APPROVED BY J. B. BROWN	PROJECT NO. 08106-001	DRAWING NO. 08106-001	DATE 08/11/11	SCALE AS SHOWN ON DRAWING	SHEET NUMBER <b>11.0</b>	PROJECT: <b>STARBUCKS COFFEE</b> <b>GRAHAM &amp; I-270</b> 1261 GRAHAM ROAD FLORISSANT, MO 63031 ST LOUIS	SHEET TITLE <b>LANDSCAPING PLAN</b>	DATE 08/11/11	DRAWN BY J. B. BROWN	CHECKED BY J. B. BROWN	APPROVED BY J. B. BROWN	PROJECT NO. 08106-001	DRAWING NO. 08106-001	DATE 08/11/11	SCALE AS SHOWN ON DRAWING	SHEET NUMBER <b>11.0</b>

1

**MEMORANDUM**

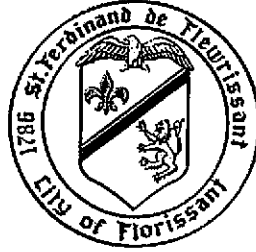

2

**CITY OF FLORISSANT**

3

*"Preserve and improve the health, safety, and welfare of our residents, businesses and the general public in the City of Florissant; while at the same time maintaining property values and improving the quality of life in the City of Florissant."*

4

5

6

7

To: Planning and Zoning Commissioners Date: December 21, 2016

8

9

From: Philip E. Lum, AIA-Building Commissioner cc: Louis B. Jearls, Jr. PE-PWLF  
Director of Public Works  
Applicant  
File

10

11

12

13

14

Subject: **1261 Graham Road (Starbucks)** - Request recommended approval to amend a Special Use, ordinance no. 7398, in a 'B-3' Zoning District.

15

16

17

**STAFF REPORT**

18

**CASE NUMBER PZ-100317-4**

19

20

**I. PROJECT DESCRIPTION:**

This is a request for recommended approval to amend a Special Use, ordinance no. 7398, in a 'B-3' Zoning District to allow a remodeling of the exterior.

21

22

23

24

**II. EXISTING SITE CONDITIONS:**

The existing property at **1261 Graham Road** is a 3024 s.f. according to public record. It has been in operation since 2007 and would like to apply for permit for exterior alterations.

25

26

27

28

29

**III. SURROUNDING PROPERTIES:**

The adjacent property to the North is 1225 Graham Road in a 'B-5' District. The property to the west is 1265 Graham in an 'B-3' District. The adjacent properties to the South are 1275 Graham and 55 Dunn Road also in the 'B-3' District.

30

31

32

33

**IV. STAFF ANALYSIS:**

The application is accompanied by professional plans PL-001 Site Plan, PL-002 Existing Exterior Elevations, PL-003 Existing Exterior Elevations, PL-004 Proposed Exterior Elevations, PL-005 Proposed Exterior Elevations, all dated December 14, 2016. Staff has the following review comments:

34

35

36

37

38

39

40 General: The Existing building consists of painted masonry. Upon examination of  
41 elevations, there is brick that is being covered by siding. Petitioner should come prepared  
42 to discuss how much painted masonry is being covered.  
43

44 PL-001 Site Plan: shows the following changes:

- 45 a. Shows improvements to the drive-through.
- 46 b. Indicates new awnings and screen.
- 47 c. Removal of existing cooler.
- 48 d. Re-seal and restriping of existing parking lot.

49 PL-004 and PL-005 Proposed Exterior Elevations

- 50 a. Shows new Nichiha Siding, a composite material
- 51 b. Indicates new canvas awnings.
- 52 c. All signs shown are within sizes permitted under the City Sign Code.

#### 54 V. MASONRY ORD. ANALYSIS

55 This proposal freshens the exterior with a new look and painted areas remain painted.  
56 Brick is to remain painted, but some is covered up. Painting to new color shall be  
57 recommended to Council.  
58

#### 59 VI. STAFF RECOMMENDATIONS:

- 60 1. The exterior changes affect the existing Special Use.
- 61 2. Any other items in need of change to the ordinance may be considered.

#### 62 **Suggested Motion to Amend a Special Use:**

- 63 1. I move to recommended approval to amend a Special Use, ordinance no. 7398, in  
64 a 'B-3' Zoning District to allow a remodeling of the exterior, according to the  
65 proposal prepared by the petitioner as described related documents presented **and**  
66 **according to the attached drawings as prepared by Starbucks Coffee**  
67 **Company and dated 12/14/16.** Approval is subject to the regulations of these  
68 ordinances, and the following additional requirements:  
69  
70

#### 71 1. **GENERAL DEVELOPMENT CONDITIONS.**

- 72 a. Unless, and except to the extent, otherwise specifically provided in  
73 ordinance no. 7398, development shall be effected only in accordance with  
74 all ordinances of the City of Florissant.  
75  
76  
77

#### 78 2. **PROJECT COMPLETION.**

79 Construction shall start within 90 days of the issuance of building permits for  
80 the project and shall be developed in accordance of the approved final  
81 development plan within 180 days of start of construction.  
82

83 (End of report and suggested motion 12/21/16)





**STARBUCKS COFFEE**  
**COMPANY SOUTH**  
 2401 UT  
 SEATTLE, WASHINGTON 98134  
 (206) 318-1575

THESE DRAWINGS AND SPECIFICATIONS ARE PREPARED BY THE ARCHITECT AND THE CONTRACTOR SHALL BE RESPONSIBLE FOR VERIFYING THE ACCURACY OF ALL INFORMATION PROVIDED TO THE ARCHITECT. THE ARCHITECT SHALL BE RESPONSIBLE FOR VERIFYING THE ACCURACY OF ALL INFORMATION PROVIDED TO THE ARCHITECT. THE ARCHITECT SHALL BE RESPONSIBLE FOR VERIFYING THE ACCURACY OF ALL INFORMATION PROVIDED TO THE ARCHITECT.

**ARCHITECT OF RECORD**  
 THIS DRAWING IS A DESIGN DEVELOPMENT DOCUMENT. THE ARCHITECT MAKES NO WARRANTY TO THE DESIGNER, CONTRACTOR, OR ANY OTHER PARTY. THE ARCHITECT SHALL BE RESPONSIBLE FOR VERIFYING THE ACCURACY OF ALL INFORMATION PROVIDED TO THE ARCHITECT.

Rev	Date	By	Description
1	12/14/19	JM	PLANT REVIEW SET

**PROJECT NAME**  
**GRAHAM & I-270**  
**PROJECT ADDRESS**  
 1261 GRAHAM RD  
 FLOISSANT, MO 63031

**STORE #** 13511  
**PROJECT #** 98139-022  
**CONCEPT** PALETTE  
**ISSUE DATE** DECEMBER 14, 2019  
**DESIGN MANAGER** TANNER WEST  
**LEED** LEED@AP  
**PRODUCTION MANAGER** ZIVA  
**CHECKED BY** ZIVA  
**DRAWN BY** ZIVA

**SHEET TITLE**  
**SITE PLAN**  
**SCALE** As indicated  
**SHEET NUMBER** PL-0001

**SHEET NOTES**

- 1) INSTALL NEW 6" CLEARANCE SIGN
- 2) INSTALL NEW ILLUMINATED 6" DIRECTIONAL SIGN ON EXISTING POSTER SIGN TO LEFT OF SIGN
- 3) INSTALL NEW PREHEAT POND
- 4) INSTALL NEW 2" PANEL WARM BOARD
- 5) INSTALL NEW PTC ON DISK ILLUMINATED SIGN
- 6) INSTALL NEW WAYFINDING GRAPHICS AS SHOWN
- 7) INSTALL NEW BOLLARD
- 8) INSTALL NEW DIGITAL ORDER SCREEN WITH CANOPY
- 9) INSTALL NEW WININGS
- 10) REPAIR SEAL AND RESEAL PAVING LOT
- 11) EXISTING LANDSCAPING TO REMAIN. TYP.
- 12) PAINT MASONRY OF TRASH ENCLOSURE TO MATCH BUILDING MASONRY
- 13) DEMOLISH EXISTING EXTERIOR DOOR AND ENCLOSURE
- 14) NEW PREHAT FENCE TO MATCH WOOD SIGN
- 15) EXISTING PARKING SPACES TO REMAIN

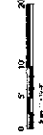
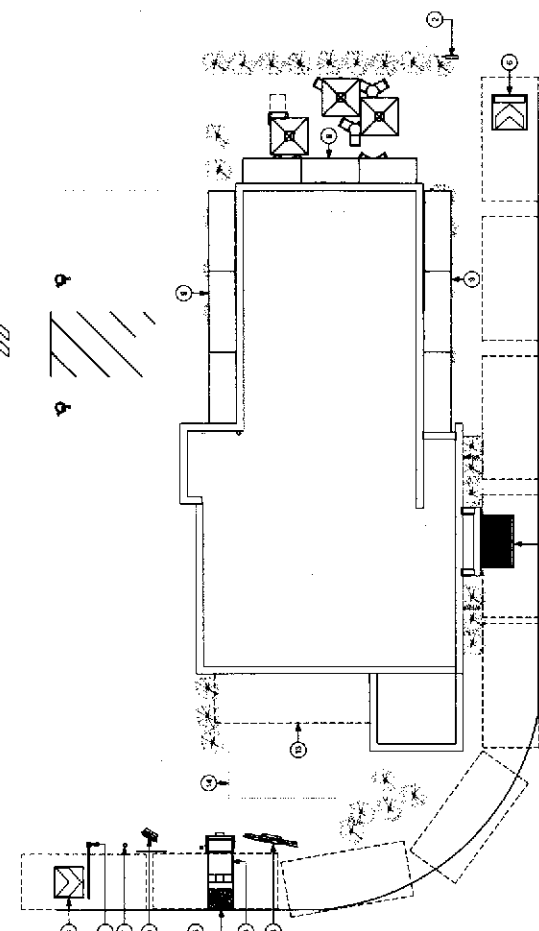

**SITE PLAN**  
 Scale: 1" = 10'-0"



STARBUCKS COFFEE  
 COMPANY  
 3000 15th Avenue  
 SEATTLE WASHINGTON 98134  
 (206) 318-1575

THESE DRAWINGS AND SPECIFICATIONS ARE  
 PREPARED BY STARBUCKS COFFEE COMPANY  
 ARCHITECTS AND SHALL REMAIN THE SOLE  
 PROPERTY OF STARBUCKS COFFEE COMPANY.  
 NO PART OF THESE DRAWINGS OR SPECIFICATIONS  
 SHALL BE REPRODUCED OR TRANSMITTED IN ANY  
 FORM OR BY ANY MEANS, ELECTRONIC OR  
 MECHANICAL, INCLUDING PHOTOCOPYING,  
 RECORDING, OR BY ANY INFORMATION STORAGE  
 AND RETRIEVAL SYSTEM, WITHOUT THE WRITTEN  
 PERMISSION OF STARBUCKS COFFEE COMPANY.  
 THE ARCHITECT SHALL BE RESPONSIBLE FOR  
 OBTAINING ALL NECESSARY PERMITS AND  
 APPROVALS FROM ALL APPLICABLE AGENCIES.  
 THE ARCHITECT SHALL BE RESPONSIBLE FOR  
 OBTAINING ALL NECESSARY PERMITS AND  
 APPROVALS FROM ALL APPLICABLE AGENCIES.

ARCHITECT OF RECORD  
 STARBUCKS COFFEE COMPANY  
 3000 15th Avenue  
 SEATTLE WASHINGTON 98134  
 (206) 318-1575

NO.	DATE	DESCRIPTION
1	10/11/17	PERMITS
2	10/11/17	PERMITS
3	10/11/17	PERMITS
4	10/11/17	PERMITS
5	10/11/17	PERMITS
6	10/11/17	PERMITS
7	10/11/17	PERMITS
8	10/11/17	PERMITS
9	10/11/17	PERMITS
10	10/11/17	PERMITS
11	10/11/17	PERMITS
12	10/11/17	PERMITS
13	10/11/17	PERMITS
14	10/11/17	PERMITS
15	10/11/17	PERMITS
16	10/11/17	PERMITS
17	10/11/17	PERMITS
18	10/11/17	PERMITS
19	10/11/17	PERMITS
20	10/11/17	PERMITS

PROJECT NAME:  
 GRAHAM & I-270  
 PROJECT ADDRESS:  
 1261 GRAHAM RD  
 FLOISSANT, MO 63031

PROJECT NO.: 1511  
 PROJECT #: 3919-022  
 CONCEPT:  
 PALETTE:  
 ISSUE DATE: DECEMBER 14, 2016  
 DESIGN MANAGER: TANNER WEST  
 LEED® CAP:  
 PRODUCTION DESIGNER: JWA  
 CHECKED BY: JWA

SHEET TITLE:  
 EXISTING EXTERIOR  
 ELEVATIONS  
 SCALE:  
 1/8" = 1'-0"

SHEET NUMBER:  
 PL-0002

**SHEET NOTES**

- 1 EXISTING LODG (SEE AREA 1-76)
- 2 EXISTING STANDING WOODWORK (AREA 1-21750)
- 3 EXISTING DRIVE TRUSS SPACING (AREA 1-36)
- 4 EXISTING GREEN CANVAS AWNING, TYP.
- 5 EXISTING SECURITY LIGHTS, TYP.
- 6 EXISTING STUB
- 7 EXISTING STORAGE WOODWORK
- 8 EXISTING CAPE WINDOWS
- 9 EXISTING METAL PARAPET CORING
- 10 EXISTING WOOD SIDING
- 11 EXISTING BRICK, PAINTED
- 12 EXISTING DOOR
- 13 EXISTING LAMINATE TO REMAIN, TYP.
- 14 EXISTING COOL BE ENCLOSURE

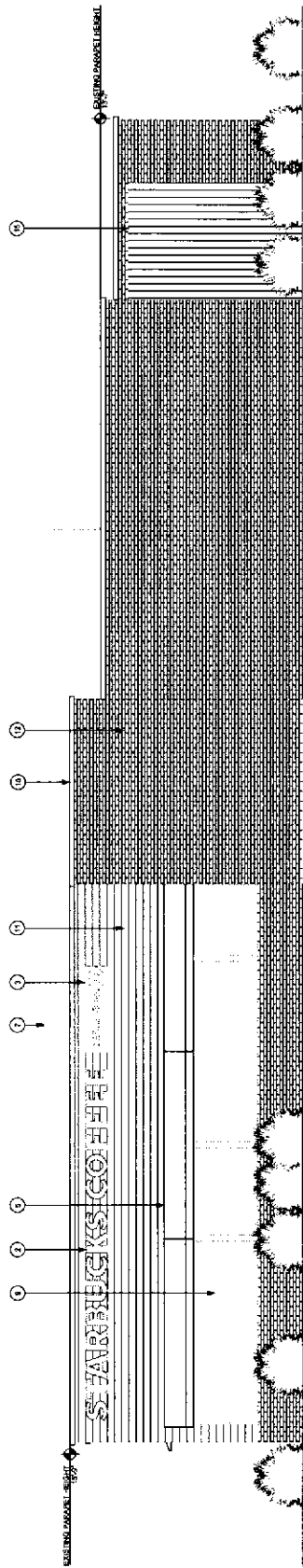

3 NORTH ELEVATION - EXISTING  
 Scale: 1/8" = 1'-0"

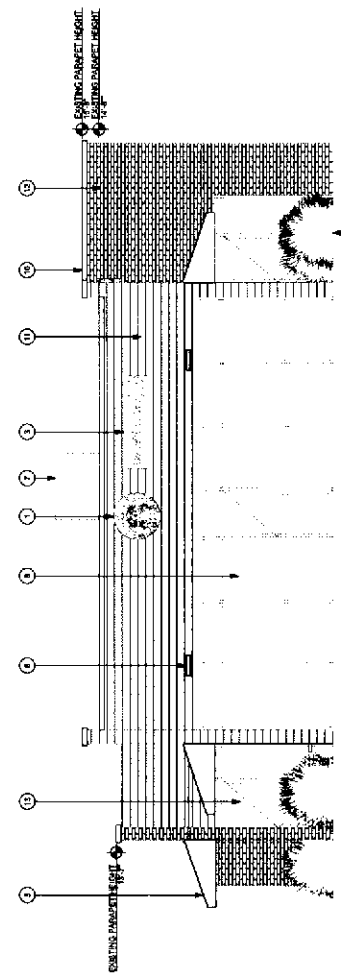

2 EAST ELEVATION - EXISTING  
 Scale: 1/8" = 1'-0"



**STARBUCKS COFFEE**  
**COMPANY SOUTH**  
 3401 UNIVERSITY AVENUE  
 SEATTLE, WASHINGTON 98114  
 (206) 318-1575

THESE DRAWINGS AND SPECIFICATIONS ARE PREPARED BY STARBUCKS COFFEE COMPANY, WHICH IS THE OWNER OF THE PROJECT. THE ARCHITECT HAS CONDUCTED VISUAL VERIFICATION OF THE PROJECT AND HAS FOUND IT TO BE IN ACCORDANCE WITH THE PROJECT SPECIFICATIONS. STARBUCKS COFFEE COMPANY AND THE ARCHITECT MAKE NO WARRANTY, EXPRESS OR IMPLIED, AS TO THE ACCURACY, COMPLETENESS, OR SUITABILITY OF THE INFORMATION PROVIDED HEREIN. THE ARCHITECT SHALL BE RESPONSIBLE FOR OBTAINING ALL NECESSARY PERMITS AND APPROVALS FROM THE APPLICABLE AGENCIES. THE ARCHITECT SHALL BE RESPONSIBLE FOR OBTAINING ALL NECESSARY PERMITS AND APPROVALS FROM THE APPLICABLE AGENCIES. THE ARCHITECT SHALL BE RESPONSIBLE FOR OBTAINING ALL NECESSARY PERMITS AND APPROVALS FROM THE APPLICABLE AGENCIES.

**ARCHITECT OF RECORD**  
 THIS DRAWING IS A DESIGN DEVELOPMENT DOCUMENT. THE ARCHITECT MAKES NO WARRANTY, EXPRESS OR IMPLIED, AS TO THE ACCURACY, COMPLETENESS, OR SUITABILITY OF THE INFORMATION PROVIDED HEREIN. THE ARCHITECT SHALL BE RESPONSIBLE FOR OBTAINING ALL NECESSARY PERMITS AND APPROVALS FROM THE APPLICABLE AGENCIES. THE ARCHITECT SHALL BE RESPONSIBLE FOR OBTAINING ALL NECESSARY PERMITS AND APPROVALS FROM THE APPLICABLE AGENCIES. THE ARCHITECT SHALL BE RESPONSIBLE FOR OBTAINING ALL NECESSARY PERMITS AND APPROVALS FROM THE APPLICABLE AGENCIES.

Date	By	Description
12/14/2016	PLM	PLANT REVIEW

**PROJECT NAME**  
**GRAHAM & I-270**  
 1261 GRAHAM RD  
 FLOISSANT, MO 63031

STORE # 13511  
 PROJECT # 38136-022  
 CONCEPT  
 PALETTE  
 ISSUE DATE: DECEMBER 14, 2016  
 DESIGN MANAGER: TANNER MEHT  
 LEED: 9.5 AP  
 PRODUCTION DESIGNED: DWA  
 CHECKED BY: ZWA

**SHEET TITLE**  
**EXISTING EXTERIOR ELEVATIONS**  
 SCALE: 1/4" = 1'-0"  
 SHEET NUMBER: PL-0003

**SHEET NOTES**

- 1 EXISTING LOGOS (AREA - 14) SEE P.002
- 2 EXISTING STARBUCKS WORKMAN (AREA - 21.16)
- 3 EXISTING DRIVE THRU SERVICE (AREA - 98) SEE P.002
- 4 EXISTING GREEN CANVAS SIGNAGE TYP
- 5 EXISTING GREEN CANVAS DRIVE THRU SIGNAGE TYP
- 6 EXISTING SECURITY LIGHTS TYP
- 7 EXISTING SIGN
- 8 EXISTING DIFFERENT WINDOWS SEE P.002
- 9 EXISTING JOE TIMONS
- 10 EXISTING METAL FRAME/TYP FORMING
- 11 EXISTING WOOD SIGNING
- 12 EXISTING BRICK PAINTED
- 13 EXISTING DOOR SEE P.002
- 14 EXISTING LANDSCAPING TO REMAIN TYP
- 15 EXISTING COOLER ENCLOSURE

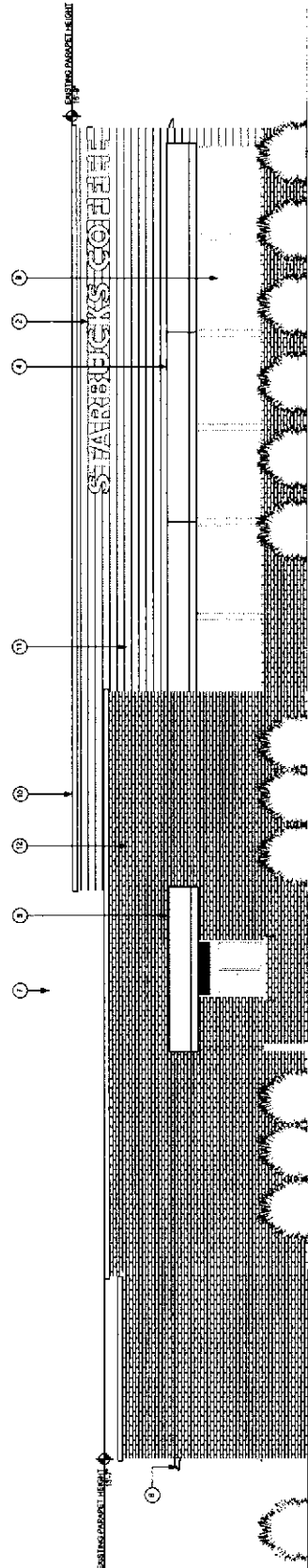

3 SOUTH ELEVATION - EXISTING  
 Scale: 1/4" = 1'-0"

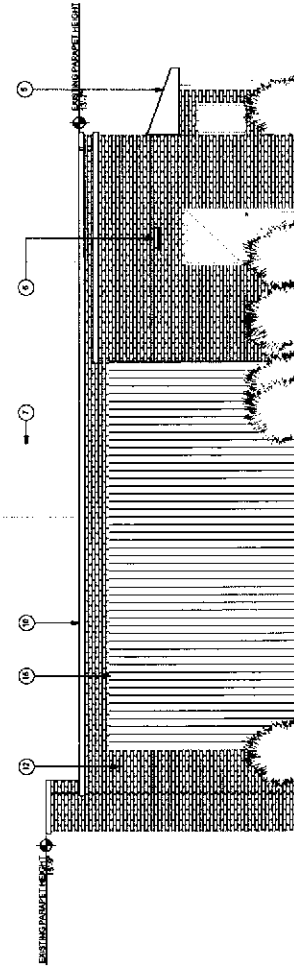

2 WEST ELEVATION - EXISTING  
 Scale: 1/4" = 1'-0"



**STARBUCKS COFFEE COMPANY**  
 3001 15th Avenue North  
 Seattle, Washington 98104  
 (206) 318-1675

THESE DRAWINGS AND SPECIFICATIONS ARE PREPARED BY STARBUCKS COFFEE COMPANY AND SHALL REMAIN THE SOLE PROPERTY OF STARBUCKS COFFEE COMPANY. THE OWNER OF THE COPYRIGHT IN THESE DRAWINGS IS STARBUCKS COFFEE COMPANY. NO PART OF THESE DRAWINGS OR SPECIFICATIONS MAY BE REPRODUCED OR TRANSMITTED IN ANY FORM OR BY ANY MEANS, ELECTRONIC OR MECHANICAL, INCLUDING PHOTOCOPYING, RECORDING, OR BY ANY INFORMATION STORAGE AND RETRIEVAL SYSTEM, WITHOUT THE WRITTEN PERMISSION OF STARBUCKS COFFEE COMPANY. THESE DRAWINGS AND SPECIFICATIONS ARE INTENDED TO BE USED IN CONJUNCTION WITH THE PERMITS AND REGULATIONS OF THE CITY OF SEATTLE AND THE STATE OF WASHINGTON. THE ARCHITECT'S LIABILITY TO THE CLIENT IS LIMITED TO THE DESIGN OF THE BUILDING AND THE ARCHITECT'S LIABILITY TO THE CLIENT IS LIMITED TO THE DESIGN OF THE BUILDING AND THE ARCHITECT'S LIABILITY TO THE CLIENT IS LIMITED TO THE DESIGN OF THE BUILDING.

**ARCHITECT OF RECORD**  
 THIS DOCUMENT IS THE PROPERTY OF GRAHAM & RAYBURN ARCHITECTS, P.C. (G&R). IT IS TO BE USED ONLY FOR THE PROJECT AND SITE SPECIFICALLY IDENTIFIED HEREIN. IT IS NOT TO BE REPRODUCED, COPIED, OR TRANSMITTED IN ANY FORM OR BY ANY MEANS, ELECTRONIC OR MECHANICAL, INCLUDING PHOTOCOPYING, RECORDING, OR BY ANY INFORMATION STORAGE AND RETRIEVAL SYSTEM, WITHOUT THE WRITTEN PERMISSION OF G&R.

Rev.	Date	Description
1	12/11/18	PLAN REVIEW OK

**PROJECT NAME**  
 GRAHAM & RAYBURN  
 1261 GRAHAM RD  
 FLOISSANT, MO 63031

**STORE #** 13511  
**PROJECT #** 39138-022  
**CONCEPT**  
**PALETTE**  
**ISSUE DATE** DECEMBER 11, 2018  
**DESIGN MANAGER** TANNER WEST  
**LEADS @ P**  
**PRODUCTION DESIGNER** N/A  
**DRAWN BY** N/A  
**CHECKED BY** N/A

**PROPOSED EXTERIOR ELEVATIONS**  
 SCALE: 1/4" = 1'-0"  
 SHEET NUMBER: PL-0004

**SHEET NOTES**

- 1) INSTALL NEW LOGO SIGN (AREA = 18 SQ.) SEE PLAN
- 2) INSTALL NEW STAIRCASE (FORMER AREA = 200)
- 3) INSTALL NEW DRIVING THROUGH STORAGE (AREA = 300)
- 4) INSTALL NEW BLACK CORNER SIGN (AREA = 100)
- 5) INSTALL NEW DRIVE THRU CANOPY
- 6) INSTALL NEW SIGNAGES, TYP.
- 7) INSTALL NEW SECURITY LIGHTS, TYP.
- 8) RAISE PARAPET TO UNIFY OVERALL PROFILE AND RISE WITH ADJACENT BUILDING PROFILE
- 9) MODIFY DRIVE THRU RAMP PARAPET TO BE CONSISTENT WITH BUILDING PROFILE
- 10) INSTALL NEW SLOPED FRONT WINDOW TO MATCH EXISTING STOREFRONT WINDOWS
- 11) INSTALL NEW BLACK METAL PARAPET CORING
- 12) INSTALL NEW WOOD-BRICK (MICHINA - VANTAGEWOOD - BARR)
- 13) PAINT EXISTING BRICK (BRYT311 - MEGA GRABER)
- 14) NEW BRICK WALL AND BRICK VENEER PAINTED TO MATCH EXISTING BRICK
- 15) EXISTING LANDSCAPING TO REMAIN, TYP.

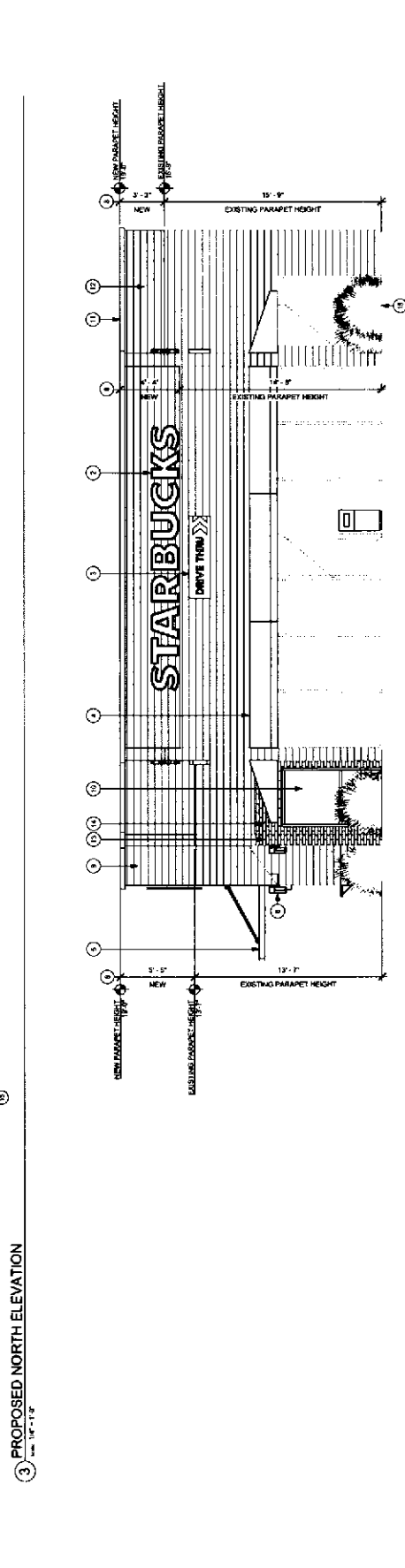
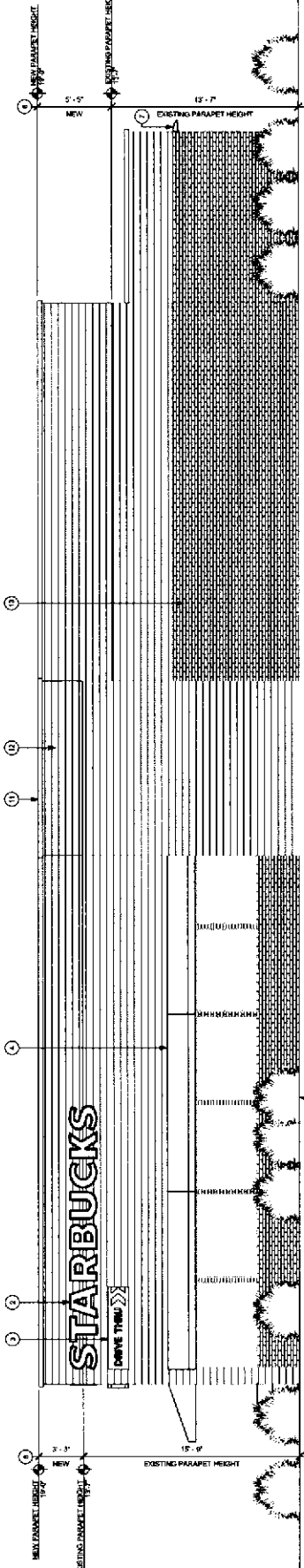



**STARBUCKS COMPANY**  
 SOUTH  
 SEATTLE, WASHINGTON 98134  
 (206) 318-1575

THESE DRAWINGS AND SPECIFICATIONS ARE THE PROPERTY OF STARBUCKS COMPANY. NO PART OF THESE DRAWINGS OR SPECIFICATIONS MAY BE REPRODUCED OR TRANSMITTED IN ANY FORM OR BY ANY MEANS, ELECTRONIC OR MECHANICAL, INCLUDING PHOTOCOPYING, RECORDING, OR BY ANY INFORMATION STORAGE AND RETRIEVAL SYSTEM, WITHOUT THE WRITTEN PERMISSION OF STARBUCKS COMPANY. THE ARCHITECT ASSUMES NO LIABILITY FOR ANY ERRORS OR OMISSIONS IN THESE DRAWINGS OR SPECIFICATIONS. THE ARCHITECT'S RESPONSIBILITY IS LIMITED TO THE DESIGN AND CONSTRUCTION OF THE BUILDING ENVELOPE.

**ARCHITECT OF RECORD**  
 THE DRAWING IS A PERSONAL REPRESENTATIVE DOCUMENT. THE ARCHITECT ASSUMES NO LIABILITY FOR ANY ERRORS OR OMISSIONS IN THESE DRAWINGS OR SPECIFICATIONS. THE ARCHITECT'S RESPONSIBILITY IS LIMITED TO THE DESIGN AND CONSTRUCTION OF THE BUILDING ENVELOPE.

Date	By	Description
12/15/11	PL	PERMITS/SET

Revision Schedule

**PROJECT NAME**  
 GRAHAM & 1-270  
 PROJECT ADDRESS  
 1281 GRAHAM RD  
 FLOISSANT, MD 83031

STORE # 13511  
 PROJECT # 39136-022  
 CONCEPT  
 PALETTE  
 ISSUE DATE: DECEMBER 14, 2016  
 DESIGNED BY: TAMMY WEST  
 LEG/09/P  
 PRODUCTION REGION: WVA  
 CHECKED BY: JWA

**PROPOSED EXTERIOR ELEVATIONS**  
 SCALE  
 SHEET NUMBER: PL-0005

**SHEET NOTES**

1. INSTALL NEW LUDO DRINK AREA - 19'x10' SEE FLOOR PLAN
2. INSTALL NEW STARBUCKS WORKAREA AREA 3'x6'
3. INSTALL NEW DRINKING STORAGE AREA 3'x4'
4. INSTALL NEW BLACK CANVAS AWNING, TYP
5. INSTALL NEW DRINKING COUNTER
6. INSTALL NEW SCENERY, TYP
7. MAKE PARAPET TO MATCH OVERALL PROFILE AND HIDE RIBS, WITH BUILDING PROFILE.
8. MAKE DRIVE THROUGH RAMP IN USE PARAPET TO BE CONSISTENT WITH BUILDING PROFILE.
9. MAKE NEW BRICKWORK TO MATCH EXISTING
10. MAKE NEW BRICKWORK TO MATCH EXISTING
11. MAKE NEW BRICKWORK TO MATCH EXISTING
12. MAKE NEW BRICKWORK TO MATCH EXISTING
13. MAKE NEW BRICKWORK TO MATCH EXISTING
14. MAKE NEW BRICKWORK TO MATCH EXISTING
15. MAKE NEW BRICKWORK TO MATCH EXISTING
16. MAKE NEW BRICKWORK TO MATCH EXISTING
17. MAKE NEW BRICKWORK TO MATCH EXISTING
18. MAKE NEW BRICKWORK TO MATCH EXISTING
19. MAKE NEW BRICKWORK TO MATCH EXISTING
20. MAKE NEW BRICKWORK TO MATCH EXISTING
21. MAKE NEW BRICKWORK TO MATCH EXISTING
22. MAKE NEW BRICKWORK TO MATCH EXISTING
23. MAKE NEW BRICKWORK TO MATCH EXISTING
24. MAKE NEW BRICKWORK TO MATCH EXISTING
25. MAKE NEW BRICKWORK TO MATCH EXISTING
26. MAKE NEW BRICKWORK TO MATCH EXISTING
27. MAKE NEW BRICKWORK TO MATCH EXISTING
28. MAKE NEW BRICKWORK TO MATCH EXISTING
29. MAKE NEW BRICKWORK TO MATCH EXISTING
30. MAKE NEW BRICKWORK TO MATCH EXISTING

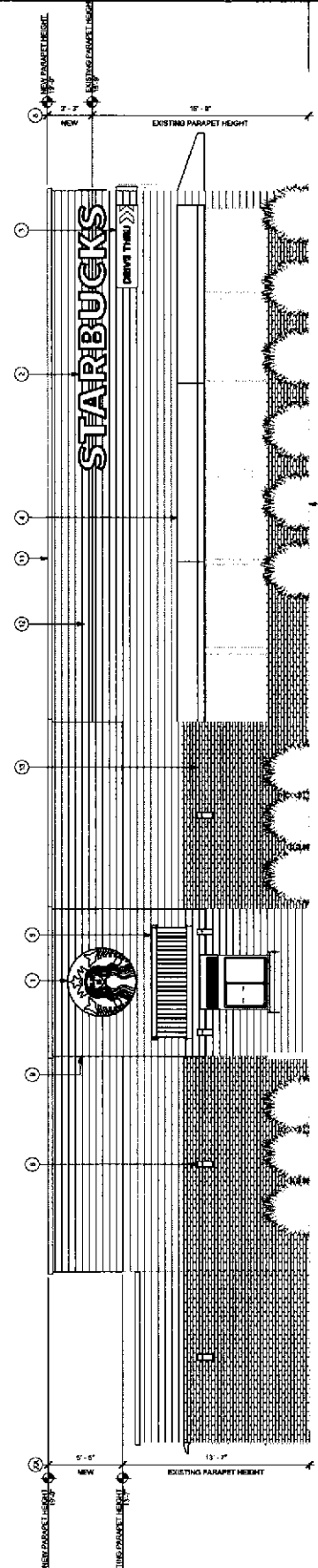

3. PROPOSED SOUTH ELEVATION  
 Scale: 1/8" = 1'-0"

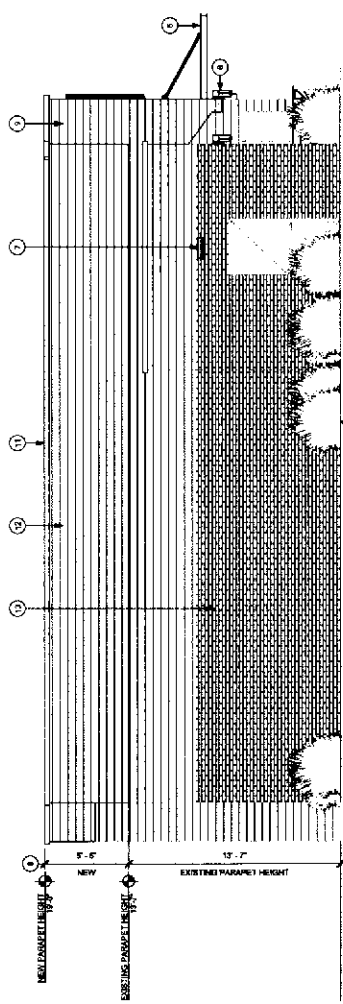

2. PROPOSED WEST ELEVATION  
 Scale: 1/8" = 1'-0"

1 INTRODUCED BY COUNCILMAN SIAM  
2 FEBRUARY 13, 2017

3  
4 BILL NO. 9257

ORDINANCE NO.

5  
6 **ORDINANCE TO AUTHORIZE AN AMENDMENT TO B-5**  
7 **ORDINANCE NO. 6868 TO ALLOW FOR A NEW SIT-DOWN CARRY-**  
8 **OUT RESTAURANT WITH SIGNAGE FOR THE PROPERTY**  
9 **LOCATED AT 2180 N. HIGHWAY 67.**

10

11 WHEREAS, the City Council passed and approved Ordinance No. 6868 rezoning  
12 Paddock Hills Shopping Center from a B-3 to B-5  
13 Extensive Commercial District to allow for the location and operation of a Bob Evans  
14 Restaurant; and

15 WHEREAS, the Planning and Zoning Commission of the City of Florissant has  
16 recommended to the City Council at their meeting of January 17, 2017 that Ordinance No. 6868  
17 be amended to allow for the addition of a sit-down, carry-out restaurant located at 2180 N. Hwy  
18 67; and

19 WHEREAS, due and lawful notice of a public hearing no. 17-02-004 on said proposed  
20 change was duly published, held and concluded on 13<sup>th</sup> of February, 2017 by the Council of the  
21 City of Florissant; and

22 WHEREAS, the Council, following said public hearing, and after due and careful  
23 deliberation, has concluded that the amendment of Ordinance No. 6868, as hereinafter set forth,  
24 to be in the best interest of the public health, safety and welfare of the City of Florissant; and

25

26 NOW, THEREFORE, BE IT ORDAINED BY THE COUNCIL OF THE CITY OF  
27 FLORISSANT, ST. LOUIS COUNTY, MISSOURI, AS FOLLOWS:

28

29

30 Section 1: Ordinance No. 6868 is hereby amended to allow for the addition of a sit-  
31 down, carry-out restaurant located at 2180 N. Hwy 67 as described in the attached plans dated  
32 12/9/16 and approved on 1/17/17 and listed below with the following stipulations:

33

34 a. C1-01 Cover Sheet, C2-0 Site Plan, C3-01 Landscape Plan, dated 12/9/16 by MB  
35 Engineering.

36 b. **McAlister's Deli** drawings: A1.0 Floor Plan dated 12/29/16 and A2.0 Elevations, dated  
37 1/4/17.

38 c. Sign Package, marked revision 1, by Design Team Sign Co., LLC, various dates.

39  
40 All Alterations to the exterior, shall be implemented as indicated on the attached plans.

41  
42 **7. FINAL SITE DEVELOPMENT PLAN**

43 A final site development plan shall be submitted to the Building Commissioner to review for  
44 compliance with the applicable "B-5" Planned Commercial Development ordinance prior to  
45 recording. Any variations from the ordinance approved by the City Council and/or the  
46 conceptual plans attached to such ordinance shall be processed in accordance with the procedure  
47 established in the Florissant Zoning Code.

48  
49 **8. AMENDMENTS TO THE SITE AND EXTERIOR BUILDING PLANS:**

50 Any changes to the approved plans attached hereto must be reviewed by the Building  
51 Commissioner. The Building Commissioner must make a determination as to the extent of the  
52 changes per the following procedure:

- 53
- 54 1. The property owner or designate representative shall submit in writing a request  
55 for an amendment to the approved plans. The building commissioner shall  
56 review the plans for consistency with the purpose and content of the proposal as  
57 originally or previously advertised for public hearing and shall make an advisory  
58 determination.
  - 59 2. If the building commissioner determines that the requested amendment is not  
60 consistent in purpose and content with the nature of the purpose as originally  
61 proposed or previously advertised for the public hearing, then an amendment to  
62 the special use permit shall be required and a review and recommendation by the  
63 planning and zoning commission shall be required and a new public hearing shall  
64 be required before the City Council.
  - 65 3. If the building commissioner determines that the proposed revisions are  
66 consistent with the purpose and content with the nature of the public hearing then  
67 a determination of non-necessity of a public hearing shall be made.
  - 68 4. Determination of minor changes: If the building commissioner determines that an  
69 amendment to the special use permit is not required and that the changes to the  
70 plans are minor in nature the Building Commissioner may approve said changes.
  - 71 5. Determination of major changes: If the Building Commissioner determines that  
72 an amendment to the B-5 is not required but the changes are major in nature, then  
73 the owner shall submit an application for review and approval by the Planning  
74 and Zoning commission.

75  
76 **9. VERIFICATION PRIOR TO OCCUPANCY PERMIT**

77 a. Any new roadway improvements shall be completed prior to the issuance of any final  
78 occupancy permit.

79  
80 b. Any new storm water detention shall be completed prior to the issuance of any occupancy  
81 permit.

82

83 c. All fencing and/or landscaping intended as screening properties shall be completed prior  
84 to the issuance of any occupancy permit, unless remitted by the Director of Public Works due to  
85 weather related factors.

86  
87 **10. GENERAL DEVELOPMENT CONDITIONS.**

88 a. Unless, and except to the extent, otherwise specifically provided herein, development shall  
89 be effected only in accordance with all ordinances of the City of Florissant.

90  
91 b. The Department of Public Works shall enforce the conditions of this ordinance in accordance  
92 with the Final Site Development Plan approved by the Planning & Zoning Commission and all  
93 other ordinances of the City of Florissant.

94  
95 **9. PROJECT COMPLETION.**

96 Construction shall start within 90 days of the issuance of building permits for the project and  
97 shall be developed in accordance of the approved final development plan within 6 months of  
98 start of construction.

99  
100 Section 2: Except as herein amended Ordinance No. 6868 shall remain in full force and  
101 effect.

102  
103 Section 3: This ordinance shall become in full force and effect immediately upon its  
104 passage and approval.

105  
106 Adopted this \_\_\_\_\_ day of \_\_\_\_\_, 2017.

107  
108 \_\_\_\_\_  
109 Jackie Pagano  
110 President of the Council

111  
112 Approved this \_\_\_\_\_ day of \_\_\_\_\_, 2017.

113  
114 \_\_\_\_\_  
115 Thomas P. Schneider  
116 Mayor, City of Florissant

117  
118  
119 ATTEST:

120  
121 \_\_\_\_\_  
122 Karen Goodwin, MMC/MRCC  
123 City Clerk



## CITY OF FLORISSANT



### PUBLIC HEARING NOTICE

Notice is hereby given in accordance with Section 405.135 of the Florissant City Code, the Zoning Ordinance, as amended, that a Public Hearing will be held by the City Council of the City of Florissant, St. Louis County, Missouri, in the Council Chambers, 955 rue St. Francois, on Monday, February 13, 2017 at 7:30 P.M. on the following proposition, to wit:

To issue an amendment to B-5 Ordinance No. 6868 to allow for a new sit-down carry-out restaurant with signage, for the property located at 2180 N Highway 67 (legal description to govern). Citizens and parties of interest will have the opportunity to be heard at said public hearing. Anyone with special needs should contact the City Clerk at least 5 days before said public hearing by calling 839-7630 or TDD 839-5142.

Karen Goodwin, MMC City Clerk.

FLORISSANT PLANNING & ZONING COMMISSION APPLICATION



City Of Florissant - Public Works  
314-839-7648

Application is hereby made to the Building Commissioner of the Department of Public works Office at the City of Florissant, Missouri, to appear before the Planning & Zoning Commission

Please Print or Type The Following Information

Property Address: 2180 N. Highway 67

Property Owners Name: Musarra 162 LLC Phone #: \_\_\_\_\_

Property Owners Address: P.O. Box 1911, Williamsville, NY 14231-1911

Business Owners Name: Southern Rock Restaurants, LLC Phone #: 615-202-5040

Business Owners Address: 1881 General George Patton Drive Suite 107, Franklin, TN 37067

DBA (Doing Business As) McAlister's Deli

Authorized Agents Name: Michael Mueller CO. Name: MB Engineering, Inc.  
(Authorized Agent to Appear Before The Commission)

Agents Address: 768 Glen Mor Drive, Belleville, IL 62221 Phone #: 618-954-0255

Request Amend the site specific B-5 ordinance to allow for the McAlister's Deli with outdoor patio seating area.

State complete request (print or type only). \_\_\_\_\_

IF A TRAFFIC STUDY IS REQUIRED FOR CERTAIN DEVELOPMENTS AND USES THE COST OF THE TRAFFIC STUDY SHALL BE PAID BY THE APPLICANT. PLEASE SUBMIT FOLDED PLANS

Michael Mueller  
Applicant's Signature

1/4/2017  
Date

Received by: CT Receipt # 598123 Amount Paid: \$125.00 Date: 1/5/17

OFFICE USE ONLY

STAFF REMARKS: \_\_\_\_\_

DATE APPLICATION REVIEWED: \_\_\_\_\_

COMMISSION ACTION TAKEN:

SIGNATURE OF STAFF WHO REVIEWED APPLICATION

RECOMMENDED APPROVAL  
PLANNING & ZONING  
CHAIRMAN

SIGN. Paul Hon DATE: 1/17/17

APPLICATION TO THE CITY OF FLORISSANT PLANNING AND ZONING COMMISSION TO ESTABLISH A B-5 PLANNED COMMERCIAL DISTRICT

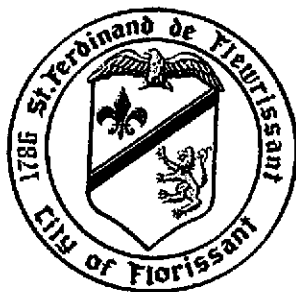

PLANNING & ZONING ACTION:

RECOMMENDED APPROVAL  
PLANNING & ZONING  
CHAIRMAN

SIGN.

DATE: 1/17/17

Address of Property:

2180 N. Highway 67

Council Ward \_\_\_\_\_ Zoning \_\_\_\_\_

Initial Date Petitioner Filed \_\_\_\_\_  
Building Commissioner to complete  
ward, zoning & date filed

PETITION FOR A B-5 RE-ZONING:

1) Comes Now Southern Rock Restaurants, LLC /dba McAlister's Deli  
(Individual's name, corporation, partnership, etc.)  
Enter name of petitioner. If a corporation, state as such. If applicable include DBA (Doing Business As).

and states to the Planning and Zoning Commission that he (she) (they) has (have) the following legal interest in the tract of land located in the City of Florissant, State of Missouri, described on page 3 of this petition.

Legal interest in the Property Lease  
State legal interest in the property. (i.e., owner of property, lease); also submit copy of deed or lease or letter of authorization from owner to seek a special use.

- A. The petitioner (s) hereby states that he (she) (they) is (are) submitting a description of the property for which the Permit is petitioned by giving bearings & distances (metes and bounds). Not required if description is identical to "B".
- B. The petitioner (s) hereby states that he (she) (they) is (are) submitting a survey or plat of the property drawn to a scale of 100 feet or less to the inch, referenced to a point easily located on the ground as street intersection, centerline of creek having a generally known name, etc., showing dimensions, bearings and distances of the property, north arrow and scale.
- C. Acreage to nearest tenth of an acre of the property for which rezoning is petitioned 1.3 Acres
- 2. The petitioner(s) hereby further state(s) that the property herein described in this petition is presently zoned in a B5 District and is presently being used for: Bob Evans Restaurant (vacant)

State current use of property, (or, state: vacant).

3. The petitioner(s) hereby state(s) the following purpose to justify the re-zoning to a B-5:  
McAlister's Deli

List purpose for this request.

4. The petitioner(s) further states(s) that they (he) (she) can comply with all of the requirements of the City of Florissant, including setback lines and off-street parking.

5. The petitioner(s) further state(s) that they (he) (she) further represent(s) and warrants that they (he) (she) has (have) not made any arrangement to pay any commission, gratuity or consideration, directly or indirectly, to any official employee or appointee of the City of Florissant, with respect to this application.

PRINT PETITIONER'S NAME David R. Blackburn

Print Name

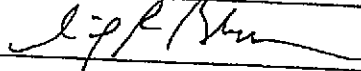
PETITIONER(S) SIGNATURE (S) 

FOR Southern Rock Restaurants, LLC

(company, corporation, partnership)

Print and sign application. If applicant is a corporation or partnership signature must be a CORPORATE OFFICER or LLC Managing PARTNER. NOTE: Corporate officer is an individual named in corporate papers.

6. I (we) hereby certify that (indicate one of the following):  
 I (we) have a legal interest in the herein above described property.  
 I am (we are) the duly appointed agent(s) of the petitioner (s), and that all information given here is true and a statement of fact.

Petitioner may assign an agent to present petition to the Commission and Council. The agent must sign the petition in this section, and provide address and telephone number

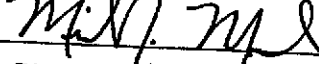
SIGNATURE 

ADDRESS 768 Glen Mor Drive Belleville IL 62221  
STREET CITY STATE ZIP CODE

TELEPHONE NUMBER 618-954-0255  
BUSINESS

I (we) the petitioner (s) do hereby appoint Michael Mueller of MB Engineering, Inc. as  
Print name of agent.  
my (our) duly authorized agent to represent me (us) in regard to this petition.

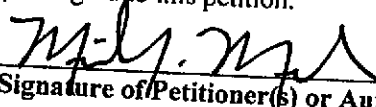
  
Signature of Petitioner(s) or Authorized Agent

**NOTE:** Be advised when the petitioner and/or his duly authorized agent appears before the Planning and Zoning Commission and make the presentation, the same individuals must also appear before the City Council for that presentation. Also if the descriptions of plats or surveys are incorrect, or if the petition form is not correctly and completely filled out it will be returned for corrections and may have to be re-submitted.

Please check the box for the appropriate type of operation then fill in applicable section (a), (b) or (c). Corporations are to submit copy of Missouri corporate papers with registration papers.

1) Type of Operation: Individual:  Partnership:  Corporation/LLC:

(a) If an Individual:

- (1) Name and Address \_\_\_\_\_
- (2) Telephone Number \_\_\_\_\_
- (3) Business Address \_\_\_\_\_
- (4) Date started in business \_\_\_\_\_
- (5) Name in which business is operated if different from (1) \_\_\_\_\_
- (6) If operating under a fictitious name, provide the name and date registered with the State of Missouri, and a copy of the registration.

(b) If a Partnership:

- (1) Names & addresses of all partners \_\_\_\_\_
- (2) Telephone numbers \_\_\_\_\_
- (3) Business address \_\_\_\_\_
- (4) Name under which business is operated \_\_\_\_\_
- (5) If operating under fictitious name, provide date the name was registered with the State of Missouri, and a copy of the registration.

(c) If a Corporation or LLC:

- |  |   |  |
|--|---|--|
|  | David R. Blackburn<br>805 Stalcup Court<br>Franklin, TN 37064 | Lisa Mathis<br>2615 Westerham Way<br>Thompsons Station, TN 37179 |
|--|---|--|
- (1) Names & addresses of all partners \_\_\_\_\_
  - (2) Telephone numbers Mr. Blackburn: 615-202-5040 Ms. Mathis: 615-351-3036
  - (3) Business address 1881 General George Patton Dr., Suite 107, Franklin, TN 37067
  - (4) State of corporation & a photocopy of incorporation papers Delaware
  - (5) Date of corporation May 5, 2011
  - (6) Missouri Corporate Number FL1154035
  - (7) If operating under fictitious name, provide the name and date registered with the State of Missouri, and a copy of registration. Southern Rock Restaurants, LLC /dba McAlister's Deli
  - (8) Name in which business is operated McAlister's Deli
  - (9) If the property location is in a strip center, give dimensions of your space under square footage and do not give landscaping information.

**Please fill in applicable information requested.**

Name David R. Blackburn

Address 1881 General George Patton Dr., Suite 107, Franklin, TN 37067

Property Owner Musarra 162 LLC, a Colorado LLC

Location of property 2180 N. Highway 67

Dimensions of property 287' x 177' (Irregular)

Current Use of Property vacant Bob Evans Restaurant

Proposed Use of Property McAlister's Deli

Type of Sign Monopole Height 25'

Type of Construction V-B Number Of Stories 1

Square Footage of Building 5,120 s.f. Number of Curb Cuts 2 (existing)

Number of Parking Spaces 71 Sidewalk Length 118'

Landscaping: No. of Trees Existing trees to remain Diameter \_\_\_\_\_  
No. of Shrubs Existing shrubs to remain, except at new patio location Size \_\_\_\_\_

Fence: Type N/A Length \_\_\_\_\_ Height \_\_\_\_\_

**PLEASE SUBMIT NINE (9) FOLDED COPIES OF THE FOLLOWING:**

1. Plan or drawing showing zoning of adjoining properties.
2. Plan or drawing showing location of property in relation to major streets and all adjoining properties.
3. Drawing showing measurement of tract and overall area of tract.
4. Plan or drawing showing proposed parking layout, landscaping, parking lighting, signage and trash enclosure.

**STAFF CHECK LIST / REVIEW SHEET**

ADDRESS OF PROPERTY 2180 N Hwy 67 CURRENT ZONING \_\_\_\_\_

PROPERTY OWNER OF RECORD \_\_\_\_\_ PHONE NO. \_\_\_\_\_

AUTHORIZED AGENT \_\_\_\_\_ PHONE NO. \_\_\_\_\_

PROPOSAL Amend 'B5.' for Mc Alister

- 1) a. Uses - Are uses stipulated  Yes /  No
- b. What current District would this proposal be a permitted use: B-5
- c. Proposed uses for out lots: \_\_\_\_\_

2) Performance Standards:

- a) Vibration: Is there any foreseen vibration problems at the property line? Yes /  No
- b) Noises: Will the operation or proposed equipment exceed 70 decibels? Yes /  No
- c) Odor is there any foreseen problem with odor? Yes /  No
- d) Smoke: Will the operation emit any smoke which could exceed a density described as No. 1 on the Ringleman Chart? Yes /  No
- e) Toxic gases: Is there any foreseen emission of toxic gases from the operation? Yes /  No
- f) Is there foreseen emission of dirt, dust, fly ash, and other forms of particle matter? Yes /  No
- g) Is there any dangerous amount of radiation produced from the operation? Yes /  No
- h) Is there any glare or heat which would be produced outside of an enclosure? Yes /  No
- i) Is screening of trash dumpsters, mechanical equipment, incinerators, etc, shown? Yes /  No
- j) Is buildings screened from adjoining residential? Yes /  No

- 3) Are height of structures shown?  Yes /  No
- 4) Are all setbacks shown?  Yes /  No
- 5) Are building square footages shown?  Yes /  No
- 6) What is the exterior construction of the buildings? existing mas.
- 7) Is off street loading shown?  Yes /  No

- 8) Parking:
- a) Does parking shown meet the ordinance? Yes /  No
- b) Is a variance required in accordance with the ordinance? Yes /  No *study req'd.*
- c) Ratio shown \_\_\_\_\_ to \_\_\_\_\_
- d) Total Number \_\_\_\_\_
- e) Will cross access and cross parking agreements be required? 75
- f) Is the parking lot adequately landscaped?  Yes /  No

- 9) Are there any signs?  Yes /  No
- Number of signs shown \_\_\_\_\_
- Type of Signs (2)
- Are sizes, heights, details, and setbacks shown? 1 post (2) wall  Yes /  No

- 10) Are existing and proposed contours shown at not more than five (5) feet intervals?  Yes /  No
- 11) Is the approximate location of all isolated trees having a trunk diameter of six inches or all tree masses and proposed landscaping shown?  Yes /  No

- 12) Are two section profiles through the site showing preliminary building form, existing natural grade and proposed final grade shown?  Yes /  No
- 13) Is proposed ingress/egress onto the site and internal traffic movements shown?  Yes /  No
- 14) Was a traffic study submitted?  
Does the City Staff recommend a traffic study?  Yes /  No
- 15) Are preliminary plans for sanitation and drainage (sanitary & storm water) facilities shown?  Yes /  No existing
- 16) Is a legal description of the property shown?  
Does legal description appear to be proper?  Yes /  No
- 17) Is an out-boundary plat of the property submitted?  Yes /  No
- 18) Suggested time limitations of construction: Start \_\_\_\_\_ ? \_\_\_\_\_ Finish \_\_\_\_\_ ? ? 12 mos?
- 19) Is parking lot lighting shown?  Yes /  No existing
- 20) Are new walkways required?  Yes /  No
- 21) Is there sufficient handicapped access?  Yes /  No
- 22) a) Are there proposed curb-cuts?  
b) Do the curb-cuts meet the City ordinances? Yes /  No  
Yes /  No N/A
- 23) Will this project require any street improvements?  Yes /  No Lindbergh  
improvement  
landscape
- 24) Staff recommendations for site development plans: \_\_\_\_\_  
\_\_\_\_\_  
\_\_\_\_\_  
\_\_\_\_\_  
\_\_\_\_\_

25) Staff Comments: \_\_\_\_\_  
\_\_\_\_\_  
\_\_\_\_\_  
\_\_\_\_\_

1/3/17  
 \_\_\_\_\_  
 Date Application reviewed  
 \_\_\_\_\_  
 Philip Ellis  
 \_\_\_\_\_  
 Building Commissioner or Staff Signature



1  
2  
3  
4  
5  
6  
7  
8  
9  
10  
11  
12  
13  
14  
15  
16  
17  
18  
19  
20  
21  
22  
23  
24  
25  
26  
27  
28  
29  
30  
31  
32  
33  
34  
35  
36  
37  
38  
39  
40

**MEMORANDUM**

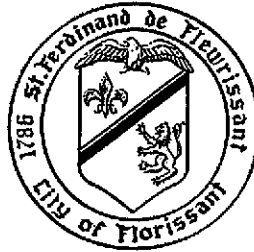

**CITY OF FLORISSANT- BUILDING DEPARTMENT**

*"Preserve and improve the health, safety, and welfare of our residents, businesses and the general public in the City of Florissant; while at the same time maintaining property values and improving the quality of life in the City of Florissant."*

To: Planning and Zoning Commissioners                      Date: January 11, 2017

From: Philip E. Lum, AIA-Building Commissioner c: Louis B. Jearls, Jr. - P.E.,  
PWL Director Public Works  
Deputy City Clerk  
Applicant  
File

Subject: Request recommended approval to amend a 'B-5', ordinance 6868, to allow for a new sit-down, carryout restaurant at **2180 N. Highway 67, McAlister's Deli.**

**STAFF REPORT**  
**CASE NUMBER PZ-011717-2**

**I. PROJECT DESCRIPTION:**

This is a request for **recommended approval** to amend a 'B-5'. Exterior modifications include a new patio dining area and exterior changes at **2180 N. Highway 67**. This amendment would change the conditions of ordinance no. 6868, however, the use is to remain restaurant, already permitted under the ordinance.

**II. EXISTING SITE CONDITIONS:**

The existing property was already developed for Bob Evans, another restaurant use.

This review pertains to the modifications and changes to the restrictions relating to the new work proposed.

**III. SURROUNDING PROPERTIES:**

The property adjacent and to the South is #1 Paddock Hills Shopping Center in a 'B-3' Extensive Business District, the US Bank to the West and the Rally's to the East are in a 'B-5' Planned Commercial District.

41 **IV. STAFF ANALYSIS:**

42 The application is accompanied by professionally completed development plans  
43 including:

44  
45 C1-01 Cover Sheet, C2-0 Site Plan, C3-01 Landscape Plan, dated 12/9/16  
46 by MB Engineering.

47  
48 Existing Boundary Adjustment survey 1 and 1 of 2, dated February 2003 by Bax  
49 Engineering.

50  
51 **McAlister's Deli** drawings: A1.0 Floor Plan dated 12/29/16 and A2.0 Elevations, dated  
52 1/4/17.

53  
54 Sign Package, marked revision 1, by Design Team Sign Co., LLC, various dates.  
55

56  
57 The following are staff comments regarding plans:  
58

59 **C1-01 Cover Sheet Comments:**

- 60 1. Notes contain details of the development.
- 61 2. Required site sections shown.
- 62 3. Parking Calculations indicate 68 required spaces and 71 provided.
- 63 4. There is an existing post sign, with no indications of a change.  
64

65 **C2-0 Site Plan Comments:**

- 66 5. Existing parking complies with new parking ordinance with the exception of the  
67 north row of parking, the location which encroaches about 4 feet into the front  
68 yard setback line.
- 69 6. A concrete dining patio is shown in proximity to existing utility lines, a gas line is  
70 shown re-routed to allow for the construction. Primary exit doors are shown in  
71 bold all with elevation about 517.00. The elevation of the grade next to the patio  
72 is at elevation 514.75 and the west edge of the proposed patio at 516.90, therefore,  
73 the patio does not require a guard and is sufficiently higher than grade, about 2'-  
74 2" to question the effectiveness of any additional bollards for patio diner  
75 protection.  
76

77 **C3-01 Landscape Plan Comments:**

- 78 7. Indicates proposed replacement of landscaping displaced by the patio.  
79

80 **A1.0 Floor Plan Comments:**

- 81 8. Indicates Patio seating of 48, trash screening area with gates, interior layout and  
82 awning overhangs.
- 83 9. An opening in the railing is shown and notes that adjust the grade to connect to a  
84 concrete walk leading to the rear of the property.  
85  
86

87 **A2.0 Elevation Comments:**

- 88 10. Rear Elevation: Dark Bronze areas on the drawings faintly show joints as if they  
89 are metal panel joints on the trash screen gates and walk-in cooler wall.  
90 11. Front Elevation: Tower is 25 feet tall with new signage, green awnings and patio.  
91 12. Left Side Elevation shows EIFS panel areas painted to match dark bronze metal  
92 on rear of building.  
93 13. Right Side Elevation also shows existing gooseneck light fixtures to be painted  
94 black.

95  
96 **Sign Package Comments:**

- 97 14. McAlister's Deli main sign is deemed to be an open letter sign. Calculation is 2/3  
98 total boxed area, or  $63 \times .67 = 42$  s.f. Wall signs are limited to 40 s.f. except as  
99 permitted under a 'B-5'.  
100 15. Awning drawing dated 10/18/16 does not match architect's elevations. A 42"  
101 guard rail is not required, therefore, the railing shown is for added safety and  
102 containment.

103  
104 **VI. STAFF RECOMMENDATIONS:**

105 **Suggested Motion-** I move to recommend approval to amend a 'B-5', ordinance 6868, to  
106 allow for a new sit-down, carryout restaurant at **2180 N. Highway 67, McAlister's Deli.**  
107 with the following amendments to ordinance no. 6868:

108  
109 The drawing attachments for this development shall be:

- 110 a. C1-01 Cover Sheet, C2-01 Site Plan, C3-01 Landscape Plan, dated 12/9/16  
111 by MB Engineering.  
112 b. **McAlister's Deli** drawings: A1.0 Floor Plan dated 12/29/16 and A2.0 Elevations,  
113 dated 1/4/17.  
114 c. Sign Package, marked revision 1, by Design Team Sign Co., LLC, various dates.  
115

116 All Alterations to the exterior, shall be implemented as indicated on the attached plans.  
117

118 **7. FINAL SITE DEVELOPMENT PLAN**

119 A final site development plan shall be submitted to the Building  
120 Commissioner to review for compliance with the applicable "B-5"  
121 Planned Commercial Development ordinance prior to recording. Any  
122 variations from the ordinance approved by the City Council and/or the  
123 conceptual plans attached to such ordinance shall be processed in  
124 accordance with the procedure established in the Florissant Zoning Code.  
125

126 **8. AMENDMENTS TO THE SITE AND EXTERIOR BUILDING PLANS:**

127 Any changes to the approved plans attached hereto must be reviewed by the  
128 Building Commissioner. The Building Commissioner must make a determination  
129 as to the extent of the changes per the following procedure:  
130

- 131 1. The property owner or designate representative shall submit in writing a  
132 request for an amendment to the approved plans. The building

133 commissioner shall review the plans for consistency with the purpose and  
134 content of the proposal as originally or previously advertised for public  
135 hearing and shall make an advisory determination.

- 136 2. If the building commissioner determines that the requested amendment is  
137 not consistent in purpose and content with the nature of the purpose as  
138 originally proposed or previously advertised for the public hearing, then  
139 an amendment to the special use permit shall be required and a review  
140 and recommendation by the planning and zoning commission shall be  
141 required and a new public hearing shall be required before the City  
142 Council.
- 143 3. If the building commissioner determines that the proposed revisions are  
144 consistent with the purpose and content with the nature of the public  
145 hearing then a determination of non-necessity of a public hearing shall be  
146 made.
- 147 4. Determination of minor changes: If the building commissioner determines  
148 that an amendment to the special use permit is not required and that the  
149 changes to the plans are minor in nature the Building Commissioner may  
150 approve said changes.
- 151 5. Determination of major changes: If the Building Commissioner  
152 determines that an amendment to the B-5 is not required but the changes  
153 are major in nature, then the owner shall submit an application for review  
154 and approval by the Planning and Zoning commission.

155  
156 **9. VERIFICATION PRIOR TO OCCUPANCY PERMIT**

- 157 a. Any new roadway improvements shall be completed prior to the issuance  
158 of any final occupancy permit.
- 159
- 160 b. Any new stormwater detention shall be completed prior to the issuance of  
161 any occupancy permit.
- 162
- 163 c. All fencing and/or landscaping intended as screening properties shall be  
164 completed prior to the issuance of any occupancy permit, unless remitted  
165 by the Director of Public Works due to weather related factors.

166  
167 **10. GENERAL DEVELOPMENT CONDITIONS.**

- 168 a. Unless, and except to the extent, otherwise specifically provided herein,  
169 development shall be effected only in accordance with all ordinances of  
170 the City of Florissant.
- 171
- 172 b. The Department of Public Works shall enforce the conditions of this  
173 ordinance in accordance with the Final Site Development Plan approved  
174 by the Planning & Zoning Commission and all other ordinances of the  
175 City of Florissant.

176  
177 **9. PROJECT COMPLETION.**

178  
179  
180  
181  
182

Construction shall start within 90 days of the issuance of building permits for the project and shall be developed in accordance of the approved final development plan within 6 months of start of construction.

(End of report and suggested motion)



Sales: Rhonda Lambert  
Project Manager:  
2180 N HWY 67  
Florissant, MO 63033

**Table of Contents**

- Page 1 -Cover Page
- Page 2 -Front Elevation
- Page 3 -East Elevation
- Page 4 -West Elevation
- Page 5 -48" Direct Mount Channel Letters
- Page 6 - Louvered Window Awnings
- Page 7 -Door Vinyl
- Page 8 -Patjo Railing

**Revision Notes**

Rev # 1

**RECOMMENDED APPROVAL  
PLANNING & ZONING  
CHAIRMAN**

SIGN:

DATE: 11/17/17



Courtesy of

**SIGN COMPANY LLC.**

731-925-4448 • 800-953-3744 • Fax 731-925-2022  
www.designteam.net



# Front Elevation

A	48" Direct Mount Channel Letters
B	73"x83" Window Awnings
C	New Door Vinyl
D	Patio Railing

Rev 1
Rev 2
Rev 3
Rev 4
Rev 5
Rev 6

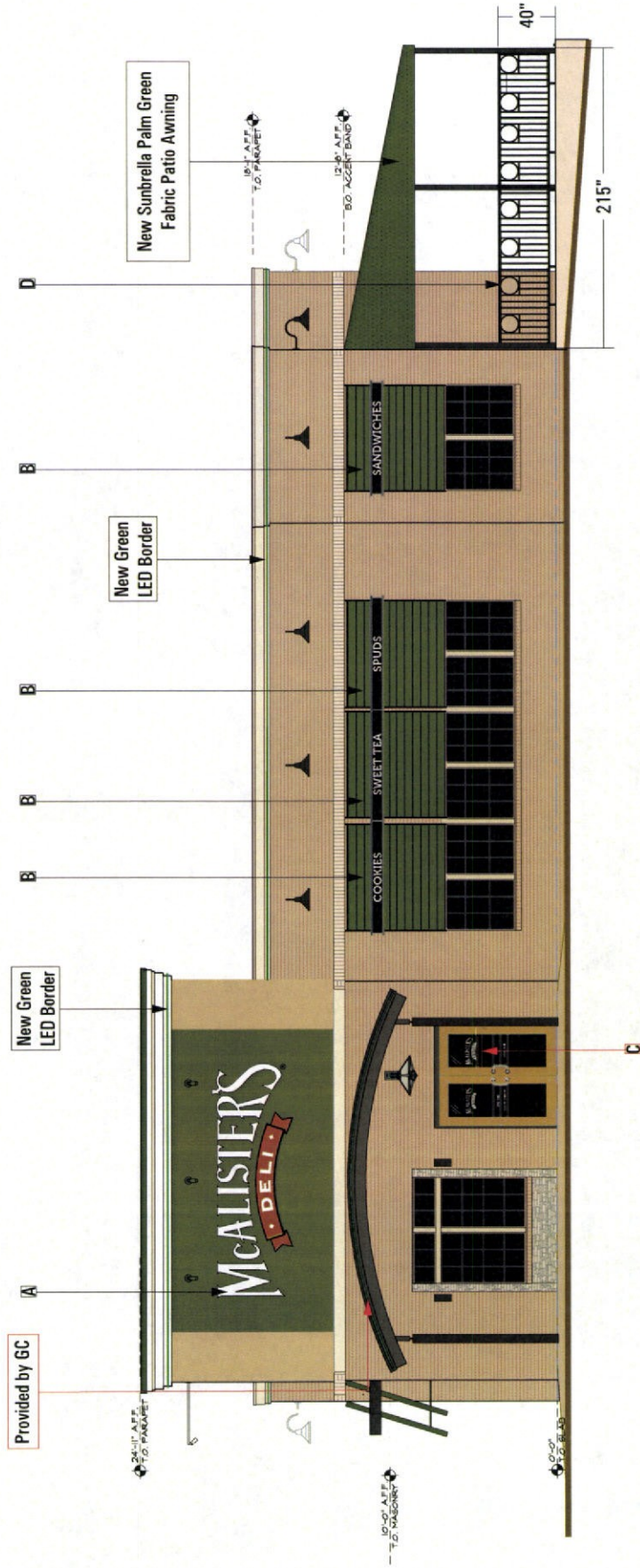

Designer: CM	Date: 1/9/16	Option # 1 - CM
Client: McAlister's of Florissant, MO		
File Path: Z:\restaurant\McAlistersFlorissantMO\Elevation		

Signature: \_\_\_\_\_  
 I have reviewed this proof in regard to: Sign type, order quantity, and accuracy of icons, symbols, and text (i.e., spelling capitalization, punctuation).  
 Print Name: \_\_\_\_\_  
 Date: \_\_\_\_\_

- Proof is Approved. Proceed With Production Of Order
- Proof is Approved With Corrections. Make Corrections As Indicated And Proceed With Production Of Order



These plans are the exclusive property of Design Team Sign Company and are the result of the original work of its employees. They are submitted to your company for the sole purpose of providing you with a visual representation of the product manufactured according to these plans. Distribution or use of these plans or the product manufactured therefrom by your company, or use of these plans to construct a product similar to one enclosed herein, is expressly forbidden. In the event your company wishes to use these plans, you must contact Design Team Sign Company to be reimbursed \$500 in compensation for time and effort entailed in creating these plans.



# East Elevation

A	48" Direct Mount Channel Letters
B	73"x83" Window Awnings
C	New Door Vinyl
D	Patio Railing

Rev 1
Rev 2
Rev 3
Rev 4
Rev 5
Rev 6

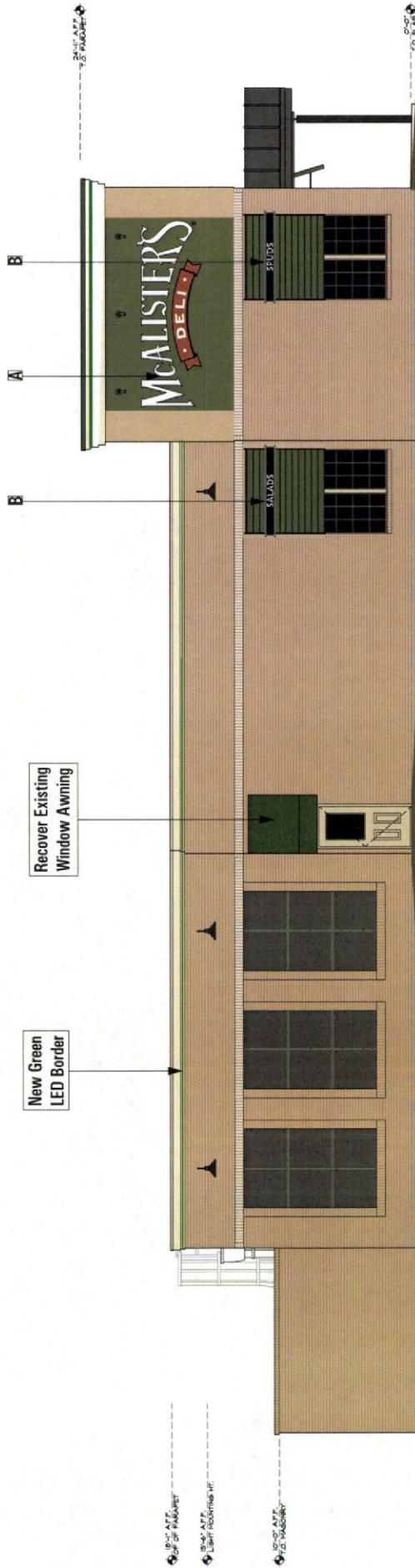

Designer: CM	Date: 1/9/16	Option # 1 - CM
Client: McAlister's of Florissant, MO		
File Path: Z:\restaurant\McAlisters\FlorissantMO\Elevation		

- Proof is Approved. Proceed With Production Of Order
- Proof is Approved With Corrections. Make Corrections As Indicated And Proceed With Production Of Order

Signature: \_\_\_\_\_  
 I have reviewed this proof in regard to: Sign type, order quantity, and accuracy of colors, symbols, and text (i.e., spelling, capitalization, punctuation).  
 Print Name: \_\_\_\_\_  
 Date: \_\_\_\_\_



These files are the exclusive property of Design Team Sign Company and are the result of the original work of its employees. They are submitted to your company for the sole purpose of providing you with a visual representation of the product manufactured according to these plans. Distribution or use of these plans to construct a product similar to that shown herein without the express written consent of Design Team Sign Company is prohibited. Design Team Sign Company expects to be reimbursed \$500 in compensation for time and effort entailed in creating these plans.



# West Elevation

Rev 1
Rev 2
Rev 3
Rev 4
Rev 5
Rev 6

D | Patio Railing

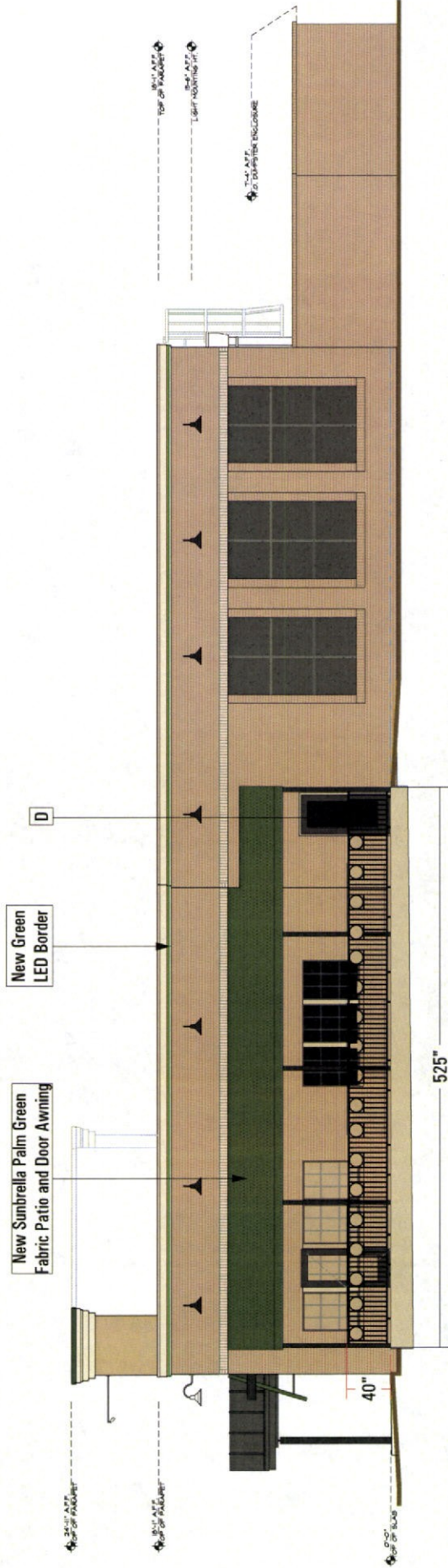

These plans are the exclusive property of Design Team Sign Company. They are submitted to your company for the sole purpose of providing a visual representation of the product manufactured according to these plans. Distribution or use of these plans to construct a product similar to one unrelated herein, is expressly forbidden. In the event your company expects to be reimbursed \$500 in compensation for time and effort entailed in creating these plans.



Signature: \_\_\_\_\_  
 I have reviewed this proof in regard to: Sign type, color, quantity, and accuracy of icons, symbols, and text (e.g., spelling capitalization, punctuation).  
 Print Name: \_\_\_\_\_  
 Date: \_\_\_\_\_

- Proof is Approved. Proceed With Production Of Order
- Proof is Approved With Corrections. Make Corrections As Indicated And Proceed With Production Of Order

Designer: CM	Date: 1/9/16	Option # 1 - CM
Client: McAlister's of Florissant, MO		
File Path: Z:\restaurant\McAlistersFlorissantMO\Elevation		





# Direct Mount Channel Letters

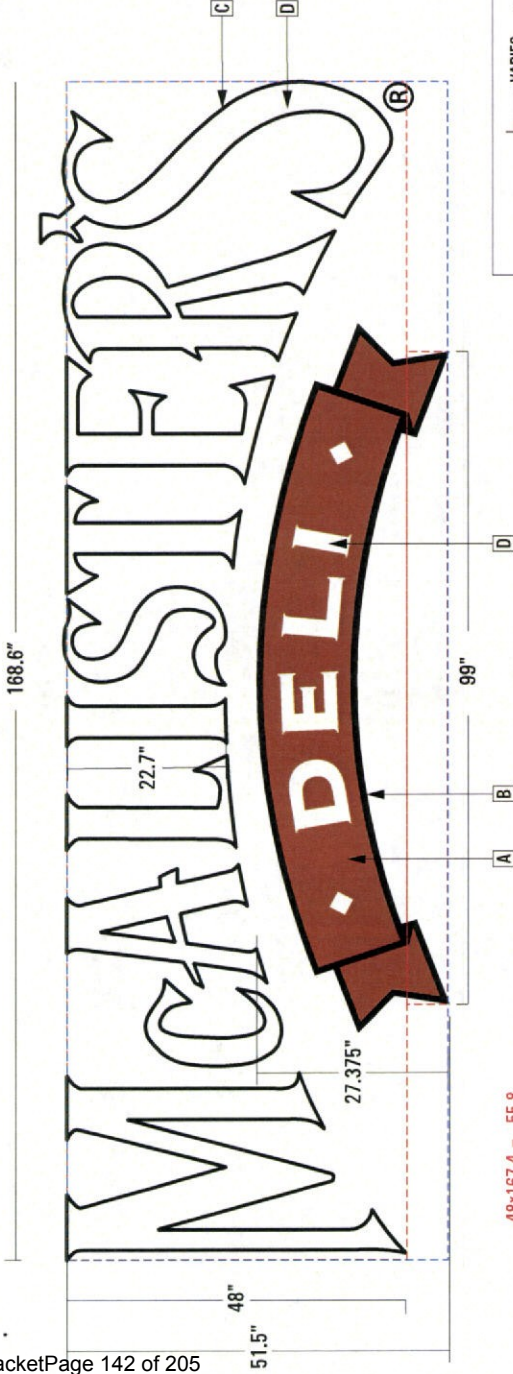

$48 \times 167.4 = 55.8$   
 $5.7 \times 93 = 3.68$   
**Total Actual SQ FT = 59.48**  
 $54.2 \times 167.4 = 63$   
**Total Boxed SQ FT = 63**

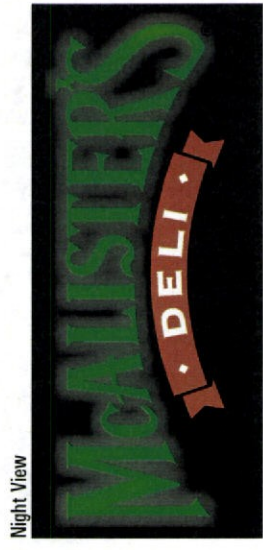

Materials	
1	.040 Aluminum Returns
2	1" Trincap
3	3/16" - 2447 White Acrylic Face
4	.090 Aluminum Back
5	Letters: Green LED - Ribbon: White LED
6	Mounting Hardware
7	1/4" Weep Hole
8	1/2" Flex Conduit
9	Toggle Switch Mounted to Box
10	Power Supply
11	Primary Electrical Leads
12	Plywood

Colors & Finishes	
A	1st Surface 751-083 Nut Brown (Ribbon)
B	1st Surface Matte Black Vinyl (Ribbon)
C	Gloss Black Trim and Returns
D	2447 White Acrylic Faces
E	Green LED (McAlister's) White LED (Ribbon)

Rev # 1 -
Rev # 2 -
Rev # 3 -
Rev # 4 -
Rev # 5 -
Rev # 6 -

**Notes**

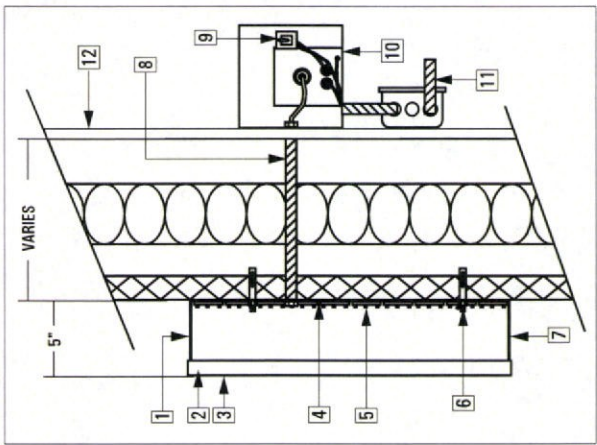

These plans are the exclusive property of Design Team Sign employees. They are submitted to your company for the sole purpose of providing you with a visual representation of the product manufactured according to these plans. Distribution or reproduction of these plans without the express written consent of Design Team Sign is prohibited. In the event you are unable to contact Design Team Sign, please contact your company or use of these plans to construct a product similar to one embodied herein, is expressly forbidden. In the event you are unable to contact Design Team Sign, please contact your company. Company expects to be reimbursed \$500 in compensation for time and effort expended in creating these plans.

Signature: \_\_\_\_\_  
 Print Name: \_\_\_\_\_  
 Date: \_\_\_\_\_

- Proof Is Approved, Proceed With Production Of Order
- Proof Is Approved With Corrections, Make Corrections As Indicated And Proceed With Production Of Order

Designer: MEB	Date: 9/29/15
Client: McAlister's	
File Path: z:\Restaurant\McAlisters/CorporateStandards	

**Design Team**  
 SIGN COMPANY LLC.



# Louver Awning

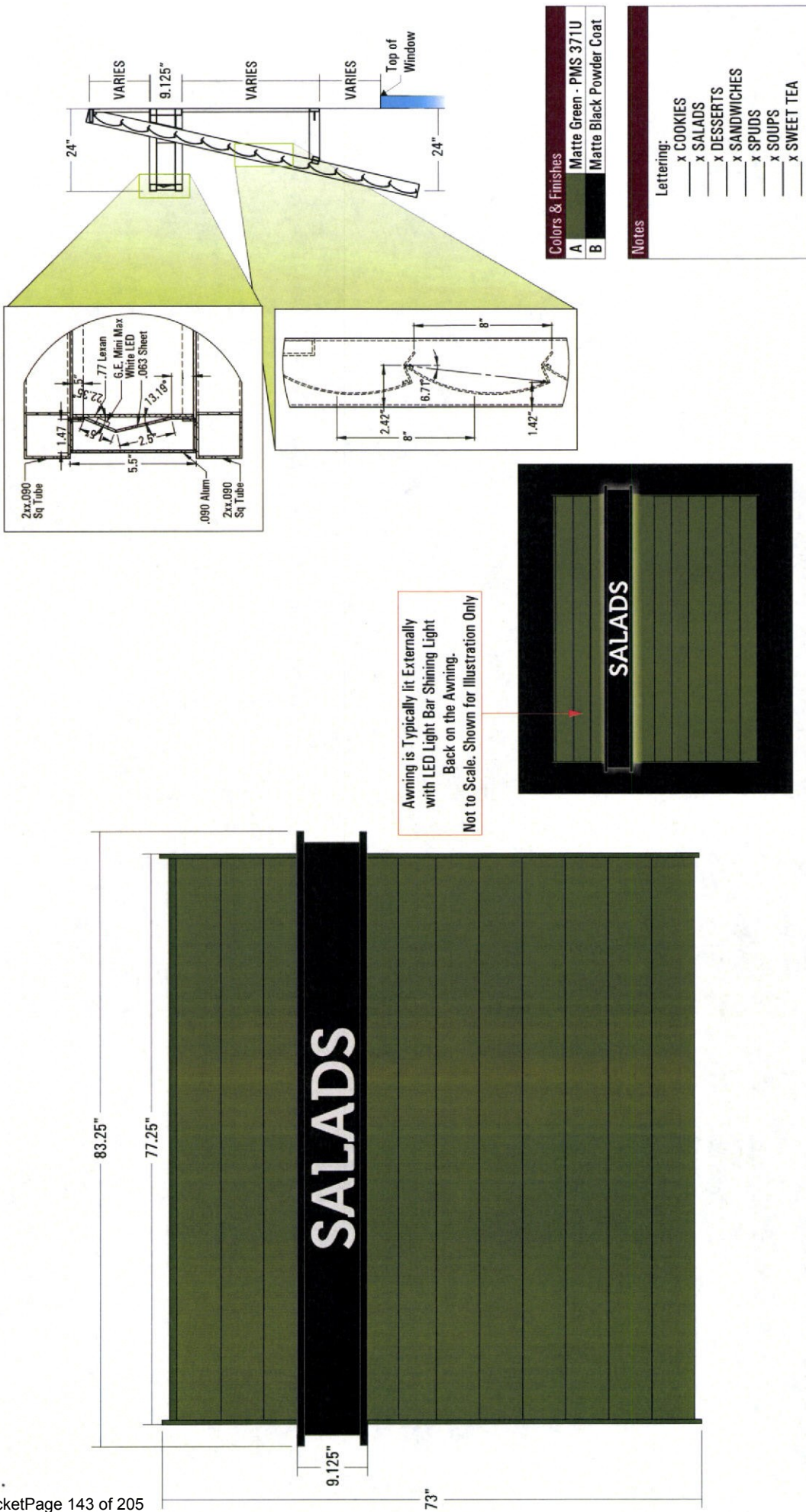

Awning is Typically lit Externally with LED Light Bar Shining Light Back on the Awning.  
 Not to Scale. Shown for Illustration Only

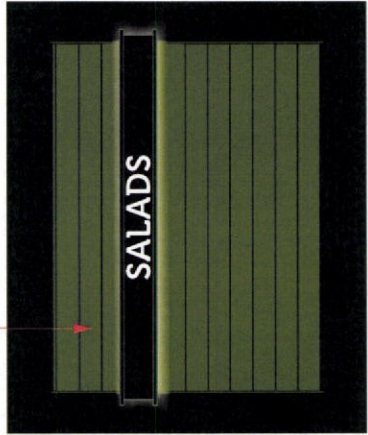

Proof is Approved. Proceed With Production Of Order  
 Proof is Approved With Corrections. Make Corrections As Indicated And Proceed With Production Of Order

**Designer:** CM      **Date:** 1-25-16  
**Client:** McAlister's  
**File Path:** z/Restaurant/McAlisters/CorporateStandards

**Signatures:** \_\_\_\_\_  
**Print Name:** \_\_\_\_\_  
**Date:** \_\_\_\_\_

**Logos:** MSSA, IFA, cUL, LITE, US, Design Team, SIGN COMPANY LLC.

These plans are the exclusive property of Design Team Sign Company and are the result of the original work of its employees. They are submitted to your company for the sole purpose of providing you with a visual representation of the product manufactured according to these plans. Distribution or reproduction of these plans without the written consent of Design Team Sign Company is prohibited. Design Team Sign Company reserves the right to use or reuse these plans to construct a product similar to the one shown on these plans. Design Team Sign Company accepts no responsibility for any errors or omissions. Design Team Sign Company accepts to be reimbursed \$500 in compensation for time and effort entailed in creating these plans.



Suite Number Font is Arial Bold  
Additional Wording is Swiss 721 BlkCn BT

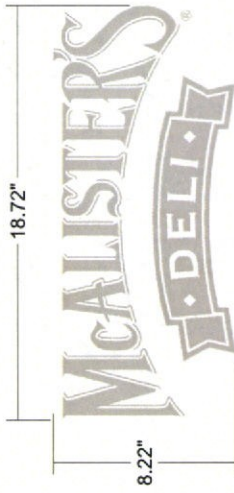
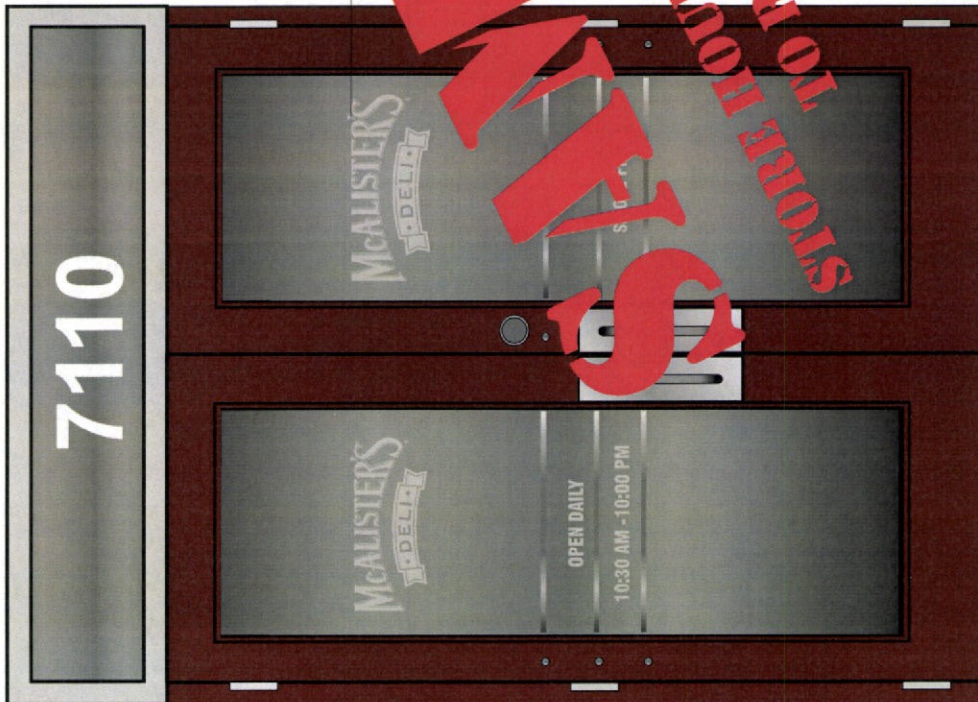

9"  
1.5" OPEN DAILY

17"  
1.4" 10:30 AM - 10:00 PM



10"  
1.5" SMOKE FREE

Specifications:

Avery SC 900-861-W Vinyl Applied  
1st Surface (McAlister's Logo, Store Hours, and Smoke Free Lettering)  
751-010 White Vinyl (Suite Number)



Designer: MEB Date: 9/30/15  
Client: McAlister's  
File Path: z:\Restaurant\McAlister's\CorporateStandards

- Proof Is Approved. Proceed With Production Of Order
- Proof Is Approved With Corrections. Make Corrections As Indicated And Proceed With Production Of Order

Signature: \_\_\_\_\_  
I have reviewed this proof in regard to: Sign type, color, quantity, and accuracy of icons, symbols, and text (e.g. spelling capitalization, punctuation).  
Print Name: \_\_\_\_\_  
Date: \_\_\_\_\_



These plans are the exclusive property of Design Team Sign Company and are the result of the original work of its employees. They are submitted to your company for the sole purpose of providing you with a visual representation of the product manufactured according to these plans. Distribution or reproduction of these plans without the express written consent of Design Team Sign Company is strictly prohibited. Design Team Sign Company accepts no responsibility for any errors or omissions that may appear in these plans. All rights reserved. © 2015 Design Team Sign Company. All other rights reserved. \$500 in compensation for time and effort retained in creating these plans.



# Patio Railings

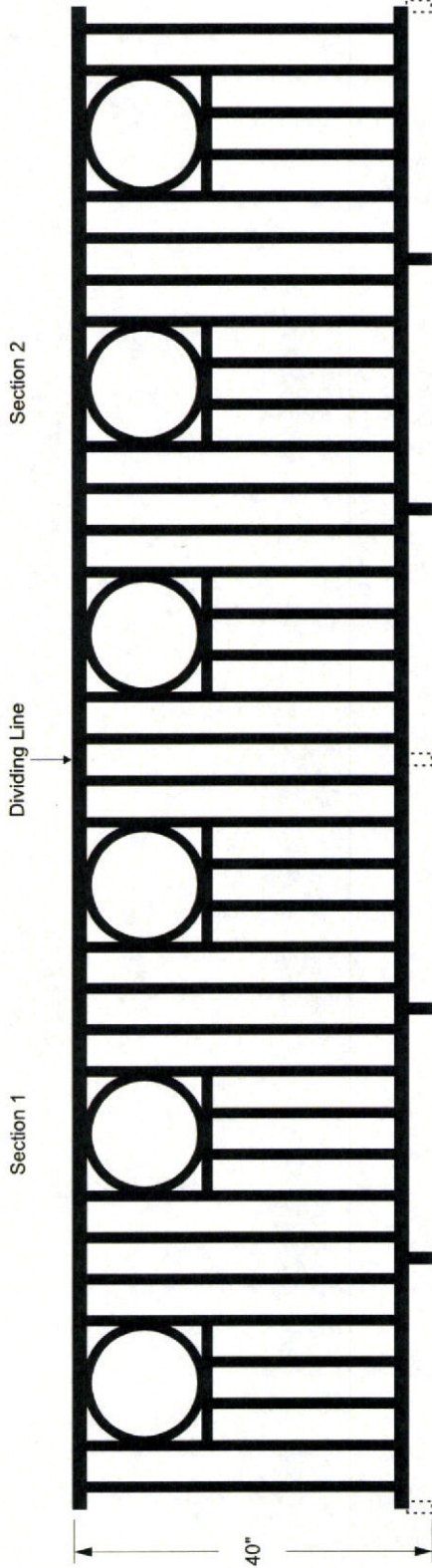

Support leg to be added between each section.  
Support legs may need to be equally distributed other than shown here.

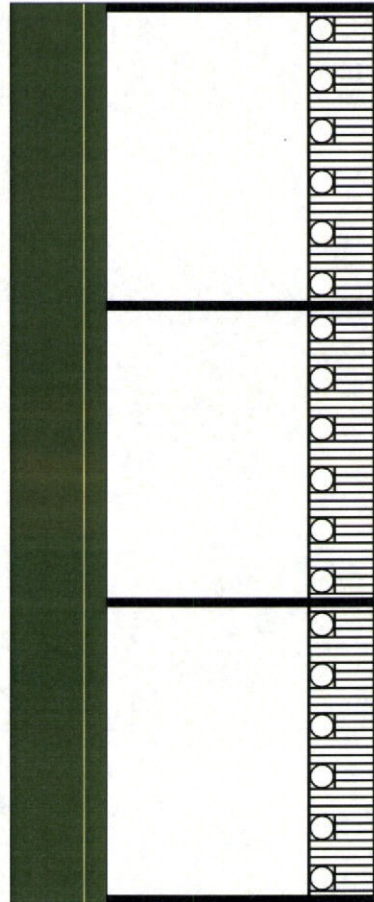

Equally distribute railings between posts.

### Colors & Finishes

A Gloss Black

- Rev #1 -
- Rev #2 -
- Rev #3 -
- Rev #4 -
- Rev #5 -
- Rev #6 -

### Notes



Designer: MEB Date: 10-18-16  
Client: McAlister's  
File Path: z/Restaurant/McA/Specs

- Proof Is Approved. Proceed With Production Of Order
- Proof Is Approved With Corrections. Make Corrections As Indicated And Proceed With Production Of Order

Signature: \_\_\_\_\_  
I have reviewed this proof in regard to: Sign type, order quantity, and accuracy of fonts, symbols, and text (e.g. spelling capitalization, punctuation).  
Print Name: \_\_\_\_\_  
Date: \_\_\_\_\_



This proof is the exclusive property of Design Team Sign Company and are the result of the original work of its employees. They are submitted to your company for the sole purpose of your review and approval. This proof is not a product manufactured according to these plans. Distribution or use of these plans in any form without the express written consent of Design Team Sign Company is prohibited. Design Team Sign Company is not responsible for any damage or loss of any kind. Design Team Sign Company expects to be reimbursed \$1000 in compensation for time and effort involved in creating these plans.

1 INTRODUCED BY COUNCILWOMAN PAGANO  
2 FEBRUARY 13, 2017

3  
4 BILL NO. 9258 ORDINANCE NO.

5  
6 AN ORDINANCE AMENDING THE GENERAL FUND BUDGET TO  
7 REFLECT \$85,000 FROM ASSET FORFEITURE FUNDS IN ESCROW  
8 TO FORFEITURE REVENUE ACCOUNT 01-4-34511 AND TO THE  
9 FORFEITURE EXPENDITURE ACCOUNT 01-5-49-61000 FOR VARIOUS  
10 POLICE DEPARTMENT EXPENDITURES.

11  
12 BE IT ORDAINED BY THE COUNCIL OF THE CITY OF FLORISSANT, ST. LOUIS  
13 COUNTY, MISSOURI, AS FOLLOWS:

14  
15 Section 1: The General Revenue Fund Budget is hereby amended to  
16 appropriate \$85,000 from asset forfeiture funds in escrow to Forfeiture Revenue  
17 Account 01-4-34511 and to Forfeiture Expenditure Account 01-5-49-61000 for  
18 various police department expenditures.  
19

20 Section 2: This ordinance shall become in force and effect immediately upon passage  
21 and approval.

22  
23  
24 Adopted this \_\_\_\_ day of \_\_\_\_\_, 2017.

25  
26  
27 \_\_\_\_\_  
28 Jackie Pagano  
29 President of the Council  
30 City of Florissant  
31

32  
33 Approved this \_\_\_\_ day of \_\_\_\_\_, 2017.

34  
35  
36 \_\_\_\_\_  
37 Thomas P. Schneider  
38 Mayor, City of Florissant  
39

40  
41 ATTEST:  
42  
43 \_\_\_\_\_  
44 Karen Goodwin, MMC/MRCC  
45 City Clerk  
46

# FLORISSANT CITY COUNCIL

## AGENDA REQUEST FORM

Date: 2/3/17

Mayor's Approval:

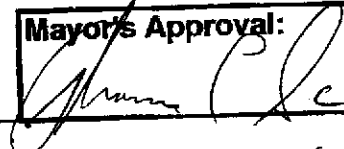

Agenda Date Requested: 2/13/17

Description of request: Request the transfer of \$85,000.00 from Forfeiture Error 1320301 to acct. 5-49610 Police Forfeiture Expenditure for anticipated expenditures per the attached memo.

Department: Police

Recommending Board or Commission:

Type of request:

Ordinances	X	Other	X
Appropriation		Liquor License	
Transfer	X	Hotel License	
Zoning Amendment		Special Presentations	
Amendment		Resolution	
Special Use Transfer		Proclamation	
Special Use		Subdivision	
Budget Amendment			
	Y/N		Y/N

Public Hearing needed: Yes / (No)

3 readings? : Yes / (No)

Back up materials attached:

Back up materials needed:

Minutes		Minutes	
Maps		Maps	
Memo	X	Memo	
Draft Ord.		Draft Ord.	

**Note:** Please include all attachments necessary for documents to be generated for inclusion on the Agenda. All agenda requests are to be turned in to the City Clerk by 5pm on Tuesday prior to the Council meeting.

For City Clerk Use Only:  
 Introduced by: \_\_\_\_\_  
 PH Speaker: \_\_\_\_\_

# FLORISSANT POLICE DEPARTMENT

## MEMORANDUM

**Date:** 01-31-2017

**To:** Mayor Schneider

**From:** Chief Timothy Lowery

OK  2-3-17

**Subject** Money Transfer

We request the transfer of funds from account 132031 Forfeiture Escrow into account 5-49610 Police Forfeiture Expenditures for the following anticipated expenditures:

Police Motorcycle and Equipment	\$ 22,000.00
Crime Scene video Camera and Equipment	\$ 5,800.00
Bullet Proof Vests/Uniform Equipment	\$ 8,000.00
Ballistic Rifle Vests First Aid pouches and Rifle clip pouches	\$ 6,200.00
Crime Scene Investigator Training School	\$ 8,000.00
Training	\$ 10,000.00
DEA Task force undercover vehicle replacement	<u>\$ 25,000.00</u>
<b>Total</b>	<b>\$ 85,000.00</b>

The total amount requested \$ 85,000.00

  
Chief Timothy J. Lowery



1 INTRODUCED BY COUNCILMAN SIAM  
2 FEBRUARY 13, 2017

3  
4 BILL NO. 9259

ORDINANCE NO.

5  
6 **ORDINANCE AUTHORIZING A TRANSFER OF SPECIAL USE**  
7 **PERMIT 7716 FROM TOT LOTS LEARNING CENTER TO**  
8 **FLORISSANT KIDS CARE CENTER LLC FOR THE OPERATION OF**  
9 **A DAY CARE LOCATED AT 2184 N. WATERFORD DRIVE.**

10  
11 WHEREAS, the Florissant Zoning Ordinance authorizes the Council of the City of  
12 Florissant, by Special Use Permit, after public hearing thereon, to permit the location and  
13 operation of a day care center; and

14 WHEREAS, pursuant to Ordinance No. 7716, Antoinette Fields d/b/a Tot Lots Learning  
15 Center was granted a Special Use Permit for the location and operation of a day care center  
16 located at 2184 N. Waterford; and

17 WHEREAS, an application has been filed by Elizabeth Johnson to transfer the Special  
18 Use Permit authorized by Ordinance No. 7716 to her name; and

19 WHEREAS, the City Council of the City of Florissant determined at its meeting on  
20 February 13, 2017 that the business operated under Ordinance No. 7716 would be operated in a  
21 substantially identical fashion as set out herein; and

22 WHEREAS; Elizabeth Johnson has accepted the terms and conditions set out in  
23 Ordinance No. 7716.

24

25 NOW, THEREFORE, BE IT ORDAINED BY THE COUNCIL OF THE CITY OF  
26 FLORISSANT, ST. LOUIS COUNTY, MISSOURI, AS FOLLOWS:

27

28

29 Section 1: The Special Use Permit authorized by Ordinance No. 7716 is hereby

30 transferred from Antionette Fields d/b/a Tot Lots Learning Center to Elizabeth Johnson d/b/a

31 Florissant Kids Care Center, LLC.

32 Section 2: The terms and conditions of said Special Permit authorized by Ordinance No.  
33 7716 shall remain in full force and effect.

34 Section 3: The Special Use Permit herein authorized shall terminate if the said business  
35 ceases operation for a period of more than ninety (90) days or when the named permittee ceases  
36 to be the owner and operator of said business.

37            Section 4: This ordinance shall become in force and effect immediately upon its passage  
38 and approval.

39  
40

41            Adopted this \_\_\_\_ day of \_\_\_\_\_, 2017.

42  
43  
44

\_\_\_\_\_  
Jackie Pagano  
President of the Council  
City of Florissant

45  
46  
47

48  
49

Approved this \_\_\_\_ day of \_\_\_\_\_, 2017.

50  
51  
52

\_\_\_\_\_  
Thomas P. Schneider  
Mayor, City of Florissant

53  
54  
55

56 ATTEST:

57  
58

\_\_\_\_\_  
Karen Goodwin, MMC/MRCC  
City Clerk

59  
60

**TRANSFER OF SPECIAL PERMIT**

AUTHORIZED BY ORDINANCE NUMBER (S) 7716

FROM Tot Lots Learning Center

TO Florissant Kids Care Center LLC

FOR Day Care

ADDRESS 2184 N. Waterford Drive, Florissant, MO 63031

Ward 9 Zoning \_\_\_\_\_ Date Filed 2/7/2017 Accepted By [Signature]

**TRANSFER OF SPECIAL USE PERMIT PETITION**

TO THE CITY COUNCIL OF THE CITY OF FLORISSANT:

1. Comes now Elizabeth Johnson and states to the City Council that he (she) (they) has (have) the following legal interest in the property located at 2184 N. Waterford Dr., Florissant, MO 63031 in the City of Florissant, Missouri. Legal interest:  Lease or  Simple Title  
(Attach signed copy of lease or deed)

2. The petitioner(s) further state that he (she) (they) has (have) not made any arrangement to pay any commission, gratuity, or consideration, directly or indirectly to any official, employee, or appointee of the City of Florissant, with respect to this petition.

3. The applicant will operate the business in the same manner and under the same conditions as set out in the original ordinance granting the special permit or any amendments thereto, except for any proposed change in sign face of an authorized sign.

PETITIONER SIGNATURE Elizabeth Johnson  
Individual's Name

FOR: Florissant Kidscare Center LLC  
Company, Corporation, Partnership

2/8/17  
CP to Council  
Ressel + Mayor

4. I (we) hereby certify that (indicate **one** only):

I (we) have a legal interest in the above described property.

I am (we are) the duly appointed agent (s) of the petitioner, and that all information given is true and a statement of fact.

SIGNATURE Elizabeth Johnson

ADDRESS 260 North Jefferson, 63031

Telephone No. (314) 309-6698 Email address Elizabeth.A.Johnson87@gmail.com

I (we) the petitioner(s) do hereby appoint \_\_\_\_\_ as my (our) duly authorized agent to represent me (us) in regard to this petition.

Elizabeth Johnson  
PETITIONER SIGNATURE

Note: Petitioner or his/her authorized agent will be the only person(s) permitted to make the presentation to the City Council.

5. Acknowledgement and consent of owner to Transfer Special Permit Petition.

Don Cherry  
SIGNATURE OF OWNER  
Don Cherry

**Information sheet to be attached to all requests for Transfer of Special Permit**

Type of Operation: (Select One)

Individual

Partnership

Corporation

LLC

**INDIVIDUAL:**

Name & address Elizabeth Johnson / 260 North Jefferson, 63031

Telephone number & email address (314) 482-6640 / ElizabethJohnson87@gmail.com

Business name/address/phone Florissant KidsCare

Copy of fictitious name registration, if applicable \_\_\_\_\_

**PARTNERSHIP:**

Name & address of partner (s) \_\_\_\_\_

Telephone number(s) and email address (s) \_\_\_\_\_

Business name/ address /phone \_\_\_\_\_

Copy of fictitious name registration, if applicable \_\_\_\_\_

**CORPORATION OR LLC:**

Name & address of all corporate officers \_\_\_\_\_

Telephone numbers & email addresses \_\_\_\_\_

Business name/address/phone \_\_\_\_\_

Photocopy of Corporation/LLC Articles and Certificate \_\_\_\_\_

Date of incorporation/LLC \_\_\_\_\_

Copy of fictitious name registration, if applicable

Copy of latest Missouri Anti-Trust affidavit (annual registration of corporate officers)



# CITY OF FLORISSANT

*Honorable Thomas P. Schneider, Mayor*

## TRANSFER OF SPECIAL USE PERMIT

The undersigned hereby acknowledges receipt of a copy of Ordinance  
Number 7716 which authorized a Special Permit:

TO: Hot - Lots Learning Center

FOR: operation of a child care center

and agree to the terms and conditions listed in said ordinance and to any  
additional term and conditions that the City Council shall deem appropriate.

Elizabeth Johnson

PRINT - NAME OF APPLICANT

Elizabeth Johnson

SIGNATURE OF APPLICANT

CITY HALL  
955 Rue St. Francois  
Florissant, MO 63031  
314 / 921-5700  
Fax: 314 / 921-7111  
TDD: 314 / 839-5142

POLICE DEPARTMENT  
1700 North Highway 67  
Florissant, MO 63033  
314 / 831-7000  
Fax: 314 / 830-6045

PARKS DEPARTMENT  
#1 James J. Eagan Drive  
Florissant, MO 63033  
314 / 921-4466  
Fax: 314 / 839-7672

HEALTH DEPARTMENT  
#1 St. Ferdinand Drive  
Florissant, MO 63031  
314 / 839-7654  
Fax: 314 / 839-7656

MUNICIPAL COURT  
1055 Rue St. Francois  
Florissant, MO 63031  
314 / 921-3322  
Fax: 314 / 839-7663

[www.florissantmo.com](http://www.florissantmo.com)

1 INTRODUCED BY COUNCILMAN HERNANDEZ  
2 JULY 12, 2010

3  
4 BILL NO. 8635

ORDINANCE NO. 7716

5  
6 **AN ORDINANCE GRANTING A SPECIAL USE PERMIT TO**  
7 **ANTIONETTE FIELDS D/B/A TOT-LOTS LEARNING CENTER, LLC TO**  
8 **ALLOW FOR AN CHILD CARE CENTER FOR THE PROPERTY**  
9 **LOCATED AT 2184 N. WATERFORD.**

10  
11 WHEREAS, the Florissant Zoning Ordinance authorizes the City Council of the City of  
12 Florissant, by Special Use Permit, after public hearing thereon, to permit the operation of child care  
13 center; and

14 WHEREAS, an application has been filed by Antoinette Fields d/b/a Tot-Lots Learning  
15 Center, LLC for the operation of a child care center located at 21840 N. Waterford.

16 WHEREAS, the Planning and Zoning Commission of the City of Florissant, at their meeting  
17 of June 21, 2010, has recommended that the said Special Use Permit be granted; and

18 WHEREAS, due notice of a public hearing on said application to be held on the 12<sup>th</sup> day of  
19 July, 2010 at 8:00 P.M. by the Council of the City of Florissant was duly published, held and  
20 concluded; and

21 WHEREAS, the Council, following said public hearing, and after due and careful  
22 consideration, has concluded that the granting of the Special Use Permit as hereinafter provided  
23 would be in the best interest of the City of Florissant.

24 NOW, THEREFORE, BE IT ORDAINED BY THE COUNCIL OF THE CITY OF  
25 FLORISSANT, ST. LOUIS COUNTY, MISSOURI, AS FOLLOWS:

26  
27 Section 1: A Special Use Permit is hereby granted to Antoinette Fields d/b/a Tot-Lots  
28 Learning Center, LLC for the operation of an child care center located at 2184 N. Waterford with the  
29 following stipulations:

- 30 1. A 6 foot sight-proof vinyl fence shall be placed around the playground.  
31 2. A solid vinyl fence, with the appropriate closures shall be placed around the  
32 trash dumpster.

33 Section 2: When the named permittee discontinues the operation of said business, the Special  
34 Use Permit herein granted shall no longer be in force and effect.

35 Section 3: This ordinance shall become in force and effect immediately upon its passage and  
36 approval.

37

38  
39  
40  
41  
42  
43  
44  
45  
46  
47  
48  
49  
50  
51  
52  
53  
54  
55  
56

Adopted this 26 day of July, 2010.

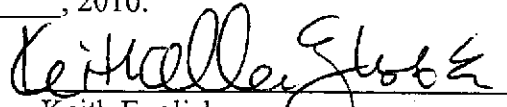
  
Keith English  
President of the Council

Approved this 27 day of July, 2010.

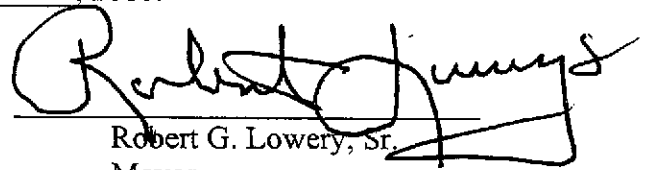
  
Robert G. Lowery, Sr.  
Mayor

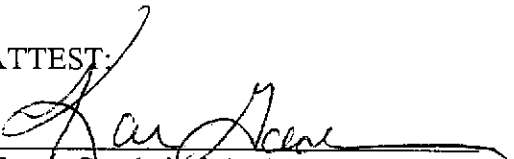
ATTEST:  
  
Karen Goodwin, MMC/MRCC  
City Clerk





# STATE OF MISSOURI



**Jason Kander**  
**Secretary of State**

## CERTIFICATE OF ORGANIZATION

WHEREAS,

*Florissant KidsCare Center LLC*  
*LC001503417*

filed its Articles of Organization with this office on the 16th day of August, 2016, and that filing was found to conform to the Missouri Limited Liability Company Act.

NOW, THEREFORE, I, Jason Kander, Secretary of State of the State of Missouri, do by virtue of the authority vested in me by law, do certify and declare that on the 16th day of August, 2016, the above entity is a Limited Liability Company, organized in this state and entitled to any rights granted to Limited Liability Companies.

IN TESTIMONY WHEREOF, I hereunto set my hand and cause to be affixed the GREAT SEAL of the State of Missouri.  
Done at the City of Jefferson, this 16th day of August, 2016.

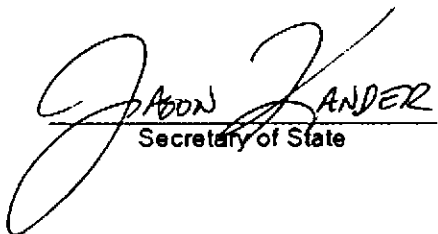
  
Secretary of State





**State of Missouri**  
**Jason Kander, Secretary of State**  
 Corporations Division  
 PO Box 778 / 600 W. Main St., Rm. 322  
 Jefferson City, MO 65102

**LC001503417**  
**Date Filed: 8/16/2016**  
**Jason Kander**  
**Missouri Secretary of State**

**Articles of Organization**

*(Submit with filing fee of \$105.00)*

1. The name of the limited liability company is

Florissant KidsCare Center LLC

*(Must include "Limited Liability Company," "Limited Company," "LC," "L.C.," "L.L.C.," or "LLC")*

2. The purpose(s) for which the limited liability company is organized:

Childcare Services

3. The name and address of the limited liability company's registered agent in Missouri is:

elizabeth ashley

johnson

260 north jefferson

florissant MO 63031

*Name*

*Street Address: May not use PO Box unless street address also provided*

*City/State/Zip*

4. The management of the limited liability company is vested in:  managers  members *(check one)*

5. The events, if any, on which the limited liability company is to dissolve or the number of years the limited liability company is to continue, which may be any number or perpetual: Perpetual

*(The answer to this question could cause possible tax consequences, you may wish to consult with your attorney or accountant!)*

6. The name(s) and street address(es) of each organizer *(PO box may only be used in addition to a physical street address):*

*(Organizer(s) are not required to be member(s), manager(s) or owner(s))*

*Name*

*Address*

*City/State/Zip*

johnson, Elizabeth

260 north jjefferson

florissant MO 63031

7.  Series LLC (OPTIONAL) Pursuant to Section 347.186, the limited liability company may establish a designated series in its operating agreement. The names of the series must include the full name of the limited liability company and are the following:

New Series:

The limited liability company gives notice that the series has limited liability.

New Series:

The limited liability company gives notice that the series has limited liability.

New Series:

The limited liability company gives notice that the series has limited liability.

*(Each separate series must also file an Attachment Form LLC 1A.)*

Name and address to return filed document:	
Name:	<u>elizabeth ashley johnson</u>
Address:	<u>Email: elizabethajohnson87@gmail.com</u>
City, State, and Zip Code:	_____

8. The effective date of this document is the date it is filed by the Secretary of State of Missouri unless a future date is otherwise indicated: \_\_\_\_\_

*(Date may not be more than 90 days after the filing date in this office)*

In Affirmation thereof, the facts stated above are true and correct:

(The undersigned understands that false statements made in this filing are subject to the penalties provided under Section 575.040, RSMo)

**All organizers must sign:**

Elizabeth Johnson  
*Organizer Signature*

ELIZABETH JOHNSON  
*Printed Name*

08/16/2016  
*Date of Signature*

1 INTRODUCED BY COUNCILMAN PAGANO, CAPUTA  
2 FEBRUARY 28, 2017

3  
4 SUBSTITUTE BILL NO. 9260

ORIDNANCE NO.

5  
6 **AN ORDINANCE AMENDING TITLE II CHAPTER 205 BY AMENDING**  
7 **SECTION 205.395 “REGULATION OF PIT BULL DOGS” TO ALLOW**  
8 **PIT BULL DOGS IN THE CITY WITH MANDATORY SPAYING AND**  
9 **NEUTERING.**

10  
11 **WHEREAS**, the City Council recognizes that dangerous dogs can be of any breed; and

12  
13 **WHEREAS**, the City Council encourages the strict enforcement of the dangerous dog  
14 ordinance and supports efforts to encourage responsible dog ownership, and

15  
16 **WHEREAS**, the City Council believes a ban on pit bull dogs is unfair but recognizes the  
17 concerns expressed about the propensity of pit bull dogs to cause serious injuries; and

18  
19 **WHEREAS**, researchers have found that mandatory sterilization is one of the  
20 requirements that directly addresses the public health problem because sterilization has been  
21 shown to reduce-dominance related aggression.

22  
23 **NOW, THEREFORE, BE IT ORDAINED BY THE COUNCIL OF THE CITY OF**  
24 **FLORISSANT, ST. LOUIS COUNTY, MISSOURI, AS FOLLOWS:**

25  
26 Section 1: Chapter 205 section 205.395 “Regulation of Pit Bull Dogs” is hereby deleted  
27 in its entirety and replaced with the following:

28  
29 Section 205.395 “Regulation of Pit Bull Dogs”

30 A. Definitions.

31 (1) Pit bull means any pit bull that is an American Pit bull Terrier, American  
32 Staffordshire Terrier, Staffordshire Bull Terrier, or any pit bull displaying the physical  
33 traits of any one or more of the above breeds, or any pit bull exhibiting those  
34 distinguishing characteristics that conform to the standards established by the American  
35 Kennel Club ("AKC") or United Kennel Club ("UKC") for any of the above breeds.

36 (2) If an owner, keeper or harbinger is unsure as to whether an unspayed and unneutered  
37 dog is a pit bull, then the owner, keeper or harbinger of the dog may make an appointment  
38 with the Director of Public Works and Health for the purpose of the Director making a  
39 determination as to whether or not such dog is a pit bull. If the pit bull owner, keeper or  
40 harbinger wishes to appeal the determination that the dog is a pit bull, then within five  
41 business days of the Director’s determination such owner, keeper or harbinger may request  
42 a hearing before the Director. The hearing shall be held no more than 30 days after the  
43 Director receives the request. The hearing may be informal and the rules of evidence not  
44 strictly observed. The decision of the Director is final.

45 B. Mandatory spaying and neutering of pit bulls; exceptions.

1 (1) No person may own, keep, or harbor any pit bull that the person in possession knew,  
2 or should have known, was a pit bull that has not been spayed or neutered unless:

3 a. The pit bull is under eight weeks of age;

4 b. The pit bull cannot be spayed or neutered without a high likelihood of suffering  
5 serious bodily harm or death due to a physical abnormality. A veterinarian must  
6 certify such a condition and determine the time frame after which the pit bull can  
7 be spayed or neutered. Within 30 days of the operative date of this ordinance, or  
8 within 30 days of taking possession or ownership of an unspayed or unneutered  
9 pit bull, the owner, keeper or harbinger must submit such documentation to be  
10 verified by the Director of Public Works and Health;

11 c. The pit bull has been present in the city for less than 30 days;

12 d. The owner, keeper or harbinger has obtained, or has submitted an application for  
13 a permit for the breeding and transfer of pit bull offspring;

14 e. The determination of the breed is under appeal pursuant to subsection (a)  
15 above; or

16 f. The pit bull is a show dog. Within thirty days of the effective date of this  
17 ordinance, or within thirty days of taking possession or ownership of an unspayed  
18 or unneutered pit bull, the owner, keeper, or harbinger shall submit a copy of the  
19 AKC or UKC organization papers to the Director of Public Works and Health  
20 demonstrating the pedigree information and the show dog registration of the pit  
21 bull and demonstrating that the pit bull conforms to the same breeding permit  
22 guidelines set forth in subsection (e) below.

23 C. Penalties for failure to spay or neuter. Any person who violates the provisions of this  
24 section requiring that a pit bull be spayed or neutered shall be subject to the following:

25 (1) A first violation shall be punishable by a fine not to exceed \$500.00 and the  
26 impoundment of the pit bull by the Director of Public Works and Health. In order for the  
27 owner, keeper or harbinger to reclaim the pit bull from the Director, in addition to paying  
28 the other charges and fees set out in this chapter, one of the following must occur:

29 a. The Director of Public Works and Health shall have a veterinarian spay or  
30 neuter the pit bull. The pit bull owner, keeper or harbinger shall pay a deposit of  
31 \$100.00 prior to the procedure and will be charged the fee for such services  
32 consisting of the actual expense incurred as established by the Director.

33 b. In the alternative, the owner, keeper or harbinger shall arrange for another  
34 veterinarian within the city to spay or neuter and shall pay the Director of Public  
35 Works and Health a fee of \$60.00, which shall cover the Director's costs of  
36 delivering the pit bull to a veterinarian of the owners, keeper's or harborers  
37 choosing. The Director shall deliver the pit bull to the veterinarian, and the  
38 veterinarian shall release the pit bull to the owner, keeper or harbinger only after  
39 the spaying or neutering is complete.

1 c. At the discretion of the Director of Public Works and Health, the Director may  
2 release the pit bull to the owner, keeper or harbinger provided that the owner,  
3 keeper or harbinger signs an affidavit swearing or affirming that such owner,  
4 keeper or harbinger will have the pit bull spayed or neutered within two weeks and  
5 will provide documentation verifying that the spaying or neutering occurred upon  
6 completion. If the owner, keeper or harbinger fails to have his or her pit bull  
7 spayed or neutered as agreed in the affidavit, the Director shall have the authority  
8 to impound the dog, and the owner, keeper or harbinger may be charged with a  
9 second violation of this section.

10 d. In the event that the Director of Public Works and Health determines that  
11 payment of any fees by the owner, keeper or harbinger of a pit bull which is  
12 impounded or otherwise taken into custody would cause extreme financial  
13 difficulty to the owner, keeper or harbinger, then the Director may, at his or her  
14 discretion, waive all or part of the fees necessary for compliance with this section.

15 (2) A second violation of this section by the owner, keeper or harbinger, shall be  
16 punishable by imprisonment for a period not to exceed six months or by a fine not to  
17 exceed \$1,000.00, or by both such fine and imprisonment. In addition, a second violation  
18 shall result in the Director of Public Works and Health impounding the pit bull and  
19 disposing of the pit bull in accordance with the provisions of this chapter.

20 D. Permit for the breeding and transfer of pit bull offspring.

21 (1) No person shall cause or allow any pit bull to breed or give birth without first  
22 obtaining a permit as described in this section.

23 (2) Keeping an unaltered male adult pit bull together with a female pit bull in heat in the  
24 same pit bull run, pen, room, or any other space where the two dogs are allowed contact  
25 with one another that would allow the pit bulls to breed is considered prima facie  
26 evidence of an owner, keeper or harbinger's intent to allow the pit bulls to breed.

27 (3) If a female pit bull is impounded pursuant to this section and the pit bull is pregnant  
28 or has offspring under eight weeks of age and such pit bull is owned, kept or harbored by  
29 a person who has caused or allowed the pit bull to breed or give birth without first  
30 obtaining a permit as described in this section, then a disposition of the unborn issue or  
31 offspring shall be made by the Director of Public Works and Health.

32 E. Granting or denying a permit.

33 (1) Requirements of permit. An owner or keeper of a pit bull may annually obtain a  
34 nontransferable permit. If more than one owner, keeper or harbinger is involved in the  
35 breeding process, each party must apply for and be granted a breeding permit. The permit  
36 may be obtained from the Director of Public Works and Health if all of the following  
37 conditions are met:

38 a. The applicant has submitted the appropriate forms and fees required by the  
39 Director of Public Works and Health in order to seek consideration for a breeding  
40 permit.

1 b. The applicant has a space in which to breed pit bulls and raise the offspring that  
2 the Director of Public Works and Health is satisfied will contain the animals as  
3 well as provide them with safe, sanitary, and humane conditions, appropriate for  
4 breeding pit bulls, which satisfies all applicable provisions of this chapter.

5 c. The Director of Public Works and Health has evaluated and reached a positive  
6 conclusion regarding the suitability of the particular pit bulls to be bred, including  
7 consideration of their lineage, age and health condition. The Director of Public  
8 Works and Health shall utilize the following guidelines in making a  
9 determination:

10 1. The owner, keeper or guardian shall provide verification that any pit  
11 bull to be bred is registered as an American Pit bull Terrier, an American  
12 Staffordshire Terrier, or a Staffordshire Bull Terrier, with the appropriate  
13 registry for its breed (American Kennel Club, United Kennel Club,  
14 American Dog Breeders Association ("ADBA")) or any other valid  
15 registry as determined by the Director of Public Works and Health.

16 2. Any pit bull to be bred must meet the pit bull breed standard, as defined  
17 by the appropriate registration agency (AK, UKC, or ADBA), for physical  
18 conformation as well as temperament.

19 3. The registered pit bull has participated in at least one approved pit bull  
20 show during the previous 365 day period or the owner, keeper or harbinger  
21 has given written notice to one of the pit bull registries listed above stating  
22 his or her intention that the pit bull will participate in an approved pit bull  
23 show. A pit bull show is defined as an event that is sanctioned in writing  
24 by one or more of the pit bull registries listed above.

25 4. Any pit bull to be bred shall have the appropriate health screenings for  
26 its breed. For pit bulls this is, at a minimum, the following health tests:  
27 Orthopedic Foundation for Animals ("OFA") or University of  
28 Pennsylvania Hip Improvement Program ("PennHIP") certification on  
29 hips, OFA on heart by a certified cardiologist and must have passed the  
30 American Temperament Testing Society temperament test.

31 d. Breeders shall not allow female pit bulls to have more than one litter per year.

32 e. Upon approval of an application, the applicant must pay the \$100.00 permit fee.

33 (2) Permit denial. The Director of Public Works and Health shall automatically deny the  
34 permit if one or more of the following occurs and the Director's decision shall be final:

35 a. The applicant fails to pay the permit fee within two weeks of notification that  
36 the application has been approved. The applicant may reapply for a permit after  
37 ten months.

38 b. The applicant has a history of allowing dogs to run loose or escape, has  
39 otherwise been found to be neglectful, has a pit bull identified as a nuisance, or  
40 has previously been determined to have violated provisions of this chapter.



1 c. The applicant has applied for a permit within the last ten months.

2 (3) Inspections of the premises.

3 a. The Director of Public Works and Health may on one or more occasions for up  
4 to one year after issuing the permit, perform an inspection of the pit bulls living  
5 quarters to ensure that the standards required to receive a permit are met. The  
6 Director will give the owner, keeper or harborer a 24-hour notice and will conduct  
7 such inspection at a reasonable time when the owner, keeper or harborer is  
8 present. The owner, keeper or harborer shall allow the Director access to conduct  
9 the inspection.

10 b. If the property does not meet the required standards, or the owner, keeper or  
11 harborer cannot be contacted for an inspection within two weeks of the Director's  
12 initial attempt or the owner, keeper or harborer fails or refuses to allow an  
13 inspection, then the Director of Public Works and Health shall not issue a permit.

14 F. Revoking a permit.

15 (1) The Director of Public Works and Health may, after conducting a hearing, revoke a  
16 breeding permit for a violation of the provisions of this section. Within five days of the  
17 Director's knowledge of any such violation, a hearing officer designated by the Director  
18 shall give notice to the owner, keeper or harborer of the pit bull in writing that such  
19 owner, keeper or harborer is in violation of this section and is subject to the revocation of  
20 his or her breeding permit. Unless the hearing is waived by the owner, keeper or harborer  
21 of the pit bull, or the hearing is scheduled on an agreed-upon date, the hearing officer  
22 shall fix a time not less than ten or more than 30 days from the date of the violation  
23 notice. The hearing officer shall fix a place for said hearing and cause all parties to be  
24 notified, not less than five days before the date of such hearing. The hearing may be  
25 informal and the rules of evidence not strictly observed. Within 15 days following the  
26 hearing, the hearing officer shall issue his or her decision to all parties. The decision of  
27 the hearing officer is final. Upon a finding of a violation, the hearing officer may revoke  
28 the permit. Any violation of this section may also be considered in future permitting  
29 decisions.

30 (2) After the Director of Public Works and Health has issued a permit, such permit may  
31 be revoked pursuant to procedures set forth in this section if a subsequent inspection of  
32 the premises reveals the area to be below the standards required for the permit, or if the  
33 owner, keeper or harborer cannot be contacted for an inspection within two weeks of the  
34 department's initial attempt, or if the owner, keeper or harborer refuses the Director of  
35 Public Works and Health or his appointee access for an inspection. If the pit bull is  
36 already pregnant or the pit bulls offspring is born, the Director may, pending a hearing,  
37 impound the pit bull or its offspring in accordance with the provisions of this chapter.  
38 After a hearing, the Director may permanently confiscate the pit bulls offspring and  
39 dispose of them in accordance with this chapter.

40 G. Transferring or selling the offspring of a pit bull.

41 (1) Any owner, keeper or harborer who offers any pit bull offspring under six months old  
42 for sale, trade, or adoption, shall prominently post such owners, keepers or harborers

1 valid breeding permit number with any offer of sale, trade, or adoption. The permit  
2 number shall also be supplied in writing to the person, corporation or entity that acquires  
3 such pit bulls offspring. The provisions of this subdivision shall not apply to a not-for-  
4 profit animal welfare and rescue organization that seeks adoptive homes for pit bulls.

5 (2) The breeder shall not remove a pit bulls offspring from the litter until such offspring  
6 are at least eight weeks of age, are fully weaned, have their first set of vaccinations, have  
7 been be de-wormed and are in good general health.

8 (3) Within three weeks of the time that the litter is whelped, the breeder shall give notice  
9 in writing to the Director of Public Works and Health of the number of offspring that  
10 were born alive. Within three weeks after the breeder transfers physical possession of  
11 each of the pit bulls offspring, the breeder shall notify the Director of Public Works and  
12 Health of the name, address, and telephone number of the new owner, keeper or harborer  
13 of each such offspring.

14 H. Penalties for failure to permit, post or report.

15 (1) Any person owning, keeping or harboring a pit bull without a required permit in  
16 violation of this section and who has not previously been found to have committed such  
17 violation shall be punishable by a fine not to exceed \$500.00.

18 (2) Any person owning, keeping or harboring a pit bull without a required permit in  
19 violation of this section and who has previously been found to have committed an  
20 infraction for the same such offense shall be punishable by imprisonment not to exceed  
21 six months or by a fine not to exceed \$1,000.00 or by both imprisonment and fine. No  
22 person shall be charged with a misdemeanor pursuant to this subsection until at least 30  
23 days have passed since any previous similar infraction or misdemeanor charge was  
24 levied.

25 (3) Any person owning, keeping or harboring a pit bull who fails to include a prominently  
26 posted permit number when transferring pit bull offspring pursuant to this section shall be  
27 punishable by a fine of \$100.00 for the first violation, \$200.00 for a second violation  
28 within a year of the first offense, and a \$500.00 fine upon the third and any subsequent  
29 violations within a year of the second offense.

30 (4) Any person owning, keeping or harboring a pit bull who fails to provide the Director  
31 of Public Works and Health with notice of the number of offspring born and information  
32 about a new owner, keeper or harborer of each offspring pursuant to this section shall be  
33 punishable by a \$100.00 fine for the first violation, a \$200.00 fine upon a second  
34 violation within one year of the first offense, and a fine of \$500.00 for the third and  
35 subsequent violations within one year of the second offense.

1 Section 2: This ordinance shall become in full force and effect immediately upon its  
2 passage and approval as provided by law.

3  
4 ADOPTED THIS \_\_\_\_ DAY OF \_\_\_\_\_, 2017.

5  
6 \_\_\_\_\_  
7 Jackie Pagano  
8 President

9  
10 APPROVED THE \_\_\_\_ DAY OF \_\_\_\_\_, 2017.

11  
12 \_\_\_\_\_  
13 Thomas P. Schneider  
14 Mayor

15  
16 ATTEST:

17  
18 \_\_\_\_\_  
19 Karen Goodwin, MMC/MRCC  
20 City Clerk

1 INTRODUCED BY COUNCILMAN PAGANO, CAPUTA  
2 FEBRUARY 13, 2017

3  
4 BILL NO. 9260

ORIDNANCE NO.

5  
6 **AN ORDINANCE AMENDING TITLE II CHAPTER 205 BY DELETING**  
7 **SECTION 205.395 “REGULATION OF PIT BULL DOGS”**

8  
9 **WHEREAS** the City Council recognizes that dangerous dogs can be of any breed; and  
10 **WHEREAS** the City Council encourages the strict enforcement of the dangerous dog  
11 ordinance and supports efforts to encourage responsible dog ownership.

12  
13 **NOW, THEREFORE, BE IT ORDAINED BY THE COUNCIL OF THE CITY OF**  
14 **FLORISSANT, ST. LOUIS COUNTY, MISSOURI, AS FOLLOWS:**

15  
16 Section 1: Chapter 205 section 205.395 “Regulation of Pit Bull Dogs” is hereby deleted  
17 in its entirety.

18  
19 Section 3: This ordinance shall become in full force and effect immediately upon its  
20 passage and approval as provided by law.

21  
22 ADOPTED THIS \_\_\_\_ DAY OF \_\_\_\_\_, 2017.

23  
24 \_\_\_\_\_  
25 Jackie Pagano  
26 President

27  
28 APPROVED THE \_\_\_\_ DAY OF \_\_\_\_\_, 2017.

29  
30 \_\_\_\_\_  
31 Thomas P. Schneider  
32 Mayor

33  
34 ATTEST:

35  
36 \_\_\_\_\_  
37 Karen Goodwin, MMC/MRCC  
38 City Clerk

1 INTRODUCED BY COUNCILMAN PAGANO, CAPUTA  
2 FEBRUARY 13, 2017

3  
4 BILL NO. 9261

ORIDNANCE NO.

5  
6 **AN ORDINANCE AMENDING TITLE II CHAPTER 205 BY AMENDING**  
7 **SECTION 205.260 "DANGEROUS ANIMALS".**  
8

9 **WHEREAS** the City Council recognizes the need to improve regulations of offenses  
10 involving dangerous animals; and

11 **WHEREAS** the City Council encourages the strict enforcement of the dangerous  
12 animal ordinance and supports efforts to encourage responsible animal ownership.  
13

14 **NOW, THEREFORE, BE IT ORDAINED BY THE COUNCIL OF THE CITY OF**  
15 **FLORISSANT, ST. LOUIS COUNTY, MISSOURI, AS FOLLOWS:**  
16

17 Section 1: Chapter 205 section 205.260 "Dangerous Animals" is hereby deleted in its  
18 entirety and replaced with the following:

19 **Section 205.260 Dangerous Animals.**

20 [Code 1980 §4-17; CC 1990 §4-93; Ord. No. 5166, 8-27-1990; Ord. No. 6053, 12-15-  
21 1997]  
22

23 A. Any animal with all or any of the following characteristics may be classified as  
24 dangerous by the Director of Public Works.

25 1. Any animal which has inflicted a severe or fatal injury on a human being on  
26 public or private property. "*Severe injury*" means any physical injury resulting  
27 directly from an animal's bite, which results in broken bones or lacerations requiring  
28 extensive physician care. The victim receiving severe injuries, as defined above, must  
29 provide the Director of Public Works with a signed physician's statement  
30 documenting the injury and the treatment qualifying such a severe injury or sign an  
31 authorization for the release of such statement. However, no animal may be declared  
32 dangerous if the threat, injury or damage was sustained by a person who, at the time,  
33 was committing a willful trespass or other tort upon the premises occupied by the  
34 owner or keeper of the animal or was teasing, tormenting, abusing or assaulting the  
35 animal or has in the past been observed or reported to have teased, tormented, abused  
36 or assaulted the animal or was committing or attempting to commit a crime.

37 2. Any animal which has bitten a human being, without provocation, on public  
38 or private property other than the property of the owner.

39 3. Any animal which, while on the owner's property, has bitten, without  
40 provocation, a human being other than the owner or a member of the owner's family  
41 who normally resides at the place where the animal is kept.

1           4. Any animal which, while off the owner's property, has inflicted a severe or  
2 fatal injury on a domestic animal, livestock or poultry without provocation.

3           5. Any animal owned or harbored primarily or in part for the purpose of  
4 fighting or any animal trained for fighting.

5           6. Any animal which, when unprovoked, chases or approaches a person upon  
6 the streets, sidewalks or any public grounds or private property other than the  
7 property of the owner in a menacing fashion, or in an apparent attitude of attack, or  
8 causes a reasonable person immediate fear of personal harm or injury, regardless of  
9 whether or not a person is injured by said animal.

10          7. Any animal with a known propensity, tendency or disposition to attack  
11 unprovoked, to cause injury or to otherwise threaten the safety of human beings or  
12 domestic animals.

13          8. The Health Department and Police Department must both prepare reports  
14 documenting the details surrounding any incident when an animal inflicts a severe or  
15 fatal injury.

16  
17 B. No animal owned by governmental or Law Enforcement Agencies when being  
18 used in the services of those agencies, as determined by the Director of Public Works  
19 may be declared to be a dangerous animal.

20  
21 C. If the Director of Public Works finds and declares that an animal is  
22 dangerous, the owner shall be provided with written notice of this declaration. If the  
23 owner cannot be located, the animal may be immediately impounded and notice shall  
24 be posted on the owner's last known address. Further, if the circumstances  
25 surrounding the classification as a "dangerous animal" under any of the definitions  
26 listing in Subsection (A) are in dispute, then the owner has the option of submitting,  
27 within five (5) working days of receipt of notice of declaration, a written request to  
28 the Director of Public Works for a hearing as follows:

29          1. A hearing board, consisting of the Director of Public Works and Health  
30 Supervisor or their designees, shall be convened within five (5) working days after  
31 receipt of a written request.

32          2. The hearing shall be informal and strict rules of evidence shall not apply.

33          3. Pending the outcome of such a hearing, the animal must be confined in such  
34 a manner so as not to be a threat to any person. The confinement may, at the sole  
35 discretion of the Director of Public Works, be on the owner's premises, at the  
36 Florissant animal shelter or with a licensed veterinarian at the owner's expense.

37          4. The hearing board shall determine whether to declare the animal to be a  
38 "dangerous animal" based upon evidence and testimony presented at the time of the  
39 hearing by the owner, in addition to witnesses, animal control personnel, Police or  
40 any other person possessing information pertinent to such determination. The

1 decision of the hearing board must be unanimous in order to declare the animal to be  
2 a "dangerous animal".

3 5. The hearing board shall issue and provide its findings to the owner within  
4 five (5) days after the hearing. In addition, the owner shall be notified of the  
5 requirements as imposed pursuant to Section 205.270 and shall advise the owner that  
6 the owner has the right to appeal under the Administrative Procedure Act. The  
7 dangerous animal may be subject to impoundment as provided for in this Code or,  
8 alternatively, the owner or possessor of the animal found to be a dangerous animal  
9 shall be required to maintain the animal as herein provided in this Code.

10  
11 **Section 205.270. Dangerous Animal, Owner's Responsibility.**

12 [Code 1980 §4-19; CC 1990 §4-94; Ord. No. 6053, 12-15-1997; Ord. No. 7255 §1, 1-  
13 10-2006]

14 A. The owner of an animal that has been declared a "dangerous animal" shall be  
15 subject to such requirements as may be imposed by the Director of Public Works or  
16 the hearing board through written notification to the owner including, but not limited  
17 to, the following:

18 1. A dangerous animal which bites or scratches a human being or any animal  
19 which is determined to be dangerous because of such biting or scratching of a human  
20 being shall be impounded for a ten (10) day rabies quarantine in accordance with the  
21 provisions of Section 205.210 of this Code.

22 2. A dangerous animal may be required to wear at all times a brightly colored  
23 orange collar with large brightly colored metal tag attached to the collar so that the  
24 animal can readily be identified as a dangerous animal.

25 3. The owner shall notify both the Health Department and Police Department  
26 immediately if a dangerous animal is loose, unconfined or missing, has attacked  
27 another animal or has attacked a human being.

28 4. The owner shall notify the Health Department within twenty-four (24)  
29 hours if a dangerous animal has died or has been sold or given away. If the animal has  
30 been sold or given away, the owner or keeper shall provide the Health Department  
31 with the name, address and telephone number of the new owner and, if the dog is kept  
32 within the City limits of Florissant, the new owner must comply with the  
33 requirements of the Code.

34 5. While on the owner's property, a dangerous animal must be securely  
35 confined indoors or in a securely enclosed and locked exterior pen or structure  
36 suitable to prevent the entry of young children and designed to prevent the animal  
37 from escaping. Such pen or structure preferably made of chain link fencing must have  
38 minimum dimensions of five (5) feet wide by ten (10) feet long and five (5) feet tall  
39 and must have secure sides and a secured enclosed top. If it has no  
40 concrete/asphalt/paver bottom-then the sides must be embedded in the ground no less  
41 than twelve (12) inches. The enclosure must also provide water and protection from  
42 the elements for the animal. The enclosure, when occupied by a dangerous animal,  
43 shall not be occupied by any other animal. If the dangerous animal is a female with

1 offspring under three (3) months of age, the offspring may occupy the same enclosure  
2 as the mother.

3 The exterior pen or structure must not be located closer than ten (10) feet from any  
4 property or fence line nor closer than twenty (20) feet from a neighboring residential  
5 house.

6 A dangerous animal may be out of its pen only in the presence of a responsible adult  
7 18 years of age or older and within a completely enclosed area with a fence  
8 constructed in such manner as to prevent the animal from jumping over or through or  
9 crawling under such fence.

10 6. No dangerous animal may be kept on a porch, patio or in any part of a  
11 house or structure that would allow the animal to exit such building on its own  
12 volition. In addition, no such animal may be kept in a house or structure when the  
13 windows are open or when screen windows or screen doors are the only obstacle  
14 preventing the animal from exiting the structure.

15 7. The owner shall display a sign on his/her premises that there is a dangerous  
16 animal on the property. This sign shall be visible and capable of being read from the  
17 public highway or thoroughfare from which the property is entered. In addition, a  
18 similar sign is required to be posted on the kennel or pen or fenced yard of such  
19 animal.

20 8. A dangerous animal may be off the owner's premises if it is muzzled and  
21 restrained by a substantial chain or non-retractable leash not exceeding six (6) feet in  
22 length and under the control of a responsible adult 18 years of age or older. The  
23 muzzle must be made in a manner that will not cause injury to the animal or interfere  
24 with its vision or respiration but must prevent it from biting any person or animal.

25 9. The owner of a dangerous animal shall present to the Health Department  
26 proof that the owner or keeper has procured liability insurance in the amount of at  
27 least one hundred thousand dollars (\$100,000.00) covering the three (3) year period  
28 during which licensing is sought. The policy shall contain a provision requiring the  
29 City of Florissant to be notified by the insurance company and the policy owner of  
30 any cancellation, termination or expiration of the policy.

31 10. All owners of dangerous animals shall, within ten (10) days of such  
32 declaration, register the animal with the Health Department and pay the annual  
33 registration fee of \$100.00. Further the owner must provide the Health Department  
34 with two (2) color photographs (one (1) showing the left profile and the other  
35 showing the right profile) of the animal, clearly showing the color and approximate  
36 size of the animal and any distinguishing marks or physical characteristics.

37 11. All owners of dangerous animals must have their animal microchipped  
38 for permanent identification and provide the Health Department with the microchip  
39 number.

40 12. All owners of dangerous animals must have their animal spayed or  
41 neutered within fourteen (14) days of declarations. An owner may request an  
42 exemption from the Director of Public Works to having their dangerous animal  
43 spayed or neutered.

44 13. The City of Florissant Health Department and Police Department shall  
45 have the authority to do random checks and six (6) month checks of all dangerous  
46 animals, their location, their pen or structure, their owners, their neighbors, and  
47 current insurance policies.



1 B. The owner of a dangerous animal shall comply with the requirements imposed by  
2 the Director of Public Works within fourteen (14) calendar days following the  
3 notification to the owner.  
4

5 C. It shall be unlawful for the owner of a dangerous animal within the City of  
6 Florissant to fail to comply with requirements and conditions set forth in this Chapter  
7 and shall be subject to the penalties prescribed under Section 100.080 of the Code of  
8 Ordinances. Any animal found to be in violation of this Code may be, in addition to  
9 other penalties provided by the Municipal Code, subject to immediate seizure and  
10 impoundment for a minimum of ten (10) days or the time necessary for the owner or  
11 keeper to show compliance with this Code, whichever is shorter, and shall be  
12 responsible for all kennel fees for the impoundment.  
13

14 Section 3: This ordinance shall become in full force and effect immediately upon its  
15 passage and approval as provided by law.  
16

17 ADOPTED THIS \_\_\_\_ DAY OF \_\_\_\_\_, 2017.  
18

19 \_\_\_\_\_  
20 Jackie Pagano  
21 President  
22

23 APPROVED THE \_\_\_\_ DAY OF \_\_\_\_\_, 2017.  
24

25 \_\_\_\_\_  
26 Thomas P. Schneider  
27 Mayor  
28

29 ATTEST:  
30

31 \_\_\_\_\_  
32 Karen Goodwin, MMC/MRCC  
33 City Clerk

1 INTRODUCED BY COUNCILMAN PAGANO  
2 FEBRUARY 13, 2017

3  
4 BILL NO. 9262 ORDINANCE NO.

5  
6 AN ORDINANCE AMENDING REVENUE ACCOUNT NO. 3490  
7 "GRANTS AND REIMBURSEMENTS" IN THE AMOUNT OF \$9,780  
8 AND APPROPRIATING THE SUM OF \$9,780 FROM THE GENERAL  
9 REVENUE FUND TO BUDGET ACCOUNT NO. 4921 "UNIFORMS" TO  
10 PURCHASE BALLISTIC VESTS AWARDED THROUGH A LOCAL  
11 LAW ENFORCEMENT BLOCK GRANT.

12  
13 BE IT ORDAINED BY THE COUNCIL OF THE CITY OF FLORISSANT, ST. LOUIS  
14 COUNTY, MISSOURI, AS FOLLOWS:

15  
16 Section 1: Revenue account no. 3490 "Grants and Reimbursements" is hereby  
17 amended by adding the amount of \$9,780 to reflect a grant received from the Local Law  
18 Enforcement Block Grant; and

19 Section 2: There is hereby appropriated and set apart from the General Revenue Fund of  
20 the City of Florissant the sum of \$9,780 to Budget Account No. 4921 "Uniforms" for the  
21 purchase of Ballistic Vests for the Police Department.

22 Section 3: This ordinance shall become in force and effect immediately upon its  
23 passage and approval.

24  
25 Adopted this \_\_\_\_ day of \_\_\_\_\_, 2017.

26  
27 \_\_\_\_\_  
28 Jackie Pagano  
29 President of the Council  
30 City of Florissant

31  
32 Approved this \_\_\_\_ day of \_\_\_\_\_, 2017.

33  
34 \_\_\_\_\_  
35 Thomas P. Schneider  
36 Mayor, City of Florissant

37  
38 ATTEST:  
39  
40 \_\_\_\_\_  
41 Karen Goodwin, MMC/MRCC  
42 City Clerk  
43  
44

# FLORISSANT CITY COUNCIL

## AGENDA REQUEST FORM

Date: 2/6/17 Mayor's Approval: 

Agenda Date Requested: 2/13/17

Description of request: Request an appropriation to acct 4921 in the amount of \$9780.00 for Ballistic Rifle Vests. We request this appropriation from acct 3490 General Revenue Fund. We were awarded this money from an LLEBB Block Grant.

Department: Police

Recommending Board or Commission:

Type of request:

Ordinances	X	Other	X
Appropriation	X	Liquor License	
Transfer		Hotel License	
Zoning Amendment		Special Presentations	
Amendment		Resolution	
Special Use Transfer		Proclamation	
Special Use		Subdivision	
Budget Amendment			
	Y/N		Y/N

Public Hearing needed: Yes / (No) 3 readings? : Yes / No

Back up materials attached:		Back up materials needed:	
Minutes		Minutes	
Maps		Maps	
Memo	X	Memo	
Draft Ord.		Draft Ord.	

**Note:** Please include all attachments necessary for documents to be generated for inclusion on the Agenda. All agenda requests are to be turned in to the City Clerk by 5pm on Tuesday prior to the Council meeting.

For City Clerk Use Only:  
 Introduced by: \_\_\_\_\_  
 PH Speaker: \_\_\_\_\_

# FLORISSANT POLICE DEPARTMENT

## MEMORANDUM

**Date:** 02-06-2017

**To:** Mayor Schneider

**From:** Chief Timothy Lowery

**Subject** Money Appropriation for Ballistic Rifle Vest Grant 2016-LLEBG-027

We request an appropriation of funds to account 4921: Uniforms in the amount of \$9,780.00. The Department applied for and received a Local Law Enforcement Block Grant (2016-LLEBG-027) to purchase 12 Rifle Grade Ballistic Vests Level III/IV in the amount of \$9,780.00 from the State of Missouri. We request the appropriation from account 3490: General Fund to complete the purchase.

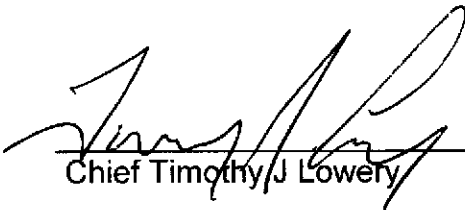

---

Chief Timothy J Lowery

ERIC R. GREITENS  
Governor

CHARLES A. (DREW) JUDEN  
Acting Director



Lewis and Clark State Building, 4<sup>th</sup> Floor  
Mailing Address: P.O. Box 749  
Jefferson City, MO 65102-0749  
Telephone: 573-751-4905  
Fax: 573-522-1908  
Internet Address:  
<http://www.dps.mo.gov>

STATE OF MISSOURI  
DEPARTMENT OF PUBLIC SAFETY  
OFFICE OF THE DIRECTOR

January 11, 2017

Capt. Randy Boden  
1700 North Hwy 67  
Florissant, MO 63033

Re: Project Title: Level III/IV Ballistic Vest Project  
Subaward Number: 2016-LLEBG-027

Dear Capt. Boden:

Enclosed you will find the check in the amount of your federal/state share award for the above mentioned subaward number and grant title under the 2017 Local Law Enforcement Block Grant (LLEBG) program.

It is recommended that agencies establish a separate bank account for these funds in order to accurately account for any interest that may be earned, if applicable. This is not required though if your accounting system can track the deposit, expenditure, and accrued interest (where applicable) on these funds. Any interest earned on the receipt of these funds is considered "program income" and must be expended during the project period (or returned to DPS).

The project period for the 2017 LLEBG program is January 1 to June 30, 2017. Funds must be obligated within this project period, and funds must be expended no later than 60 days following the project period end date (August 29, 2017).

Your agency was approved for a specific quantity of a type of equipment. While you are allowed to purchase a different make, model, or manufacturer if so desired, you may not purchase more than the approved quantity of any type of item with grant monies. If your subaward requires a budget revision, a request must be submitted in WebGrants through the "Subaward Adjustment" component of the "My Grants" module. Subaward Adjustments must be submitted no later than 30 days prior to the end of the project period so requests will not be accepted after May 31, 2017.

Following the purchase and payment of approved equipment items, your agency is required to submit a "Status Report". In WebGrants, select "My Grants", then select your grant title, next select "Status Reports", and click "Add". Please refer to the Compliance Webinar Training posted on the DPS-LLEBG webpage at <http://dps.mo.gov/dir/programs/cjle/llebg.php> if you need a refresher following the Compliance Training on how to complete this report and the required attachments. A Status Report should be submitted immediately following the expenditure of funds but no later than September 11, 2017.

Upon submission of the Status Report, the Missouri Department of Public Safety will determine if there are any unexpended grant monies or unexpended program income monies and will contact your agency with further instructions if so.

If you have questions, please contact your DPS Internal Contact, which is identified in the "General Information" component of the grant within WebGrants.

Sincerely,

Heather Haslag  
CJ/LE Program Manager

cc: File

Enclosure

TREASURER OF THE STATE OF MISSOURI

JEFFERSON CITY, MISSOURI

80-310  
815

A8369780

IF NOT PRESENTED FOR PAYMENT WITHIN ONE YEAR FROM THE DATE OF ISSUANCE, THIS CHECK SHALL BE VOID. NO STATUTE 30.206

PAY EXACTLY THE SUM OF  
TO THE ORDER OF

\*\*\*\*\*9,780 DOLLARS AND --00 CENTS

Account Protected via Positive Pay

CITY OF FLORISSANT-TREASURER  
955 RUE ST FRANCOIS  
FLORISSANT MO 63031

DATE  
01-11-2017

\$ \*\*\*\*\*9,780.00



*Sarah Stebbins*  
COMMISSIONER OF ADMINISTRATION



*Eric J. Schmidt*  
STATE TREASURER

⑈ 18369780 ⑈ ⑆ 08 1503 10 2 ⑆ ⑈ 000 13 2004 ⑈

STATE OF MISSOURI--REMITTANCE ADVICE

SERIES A		CHECK NO. 8369780		DISTRIBUTION CK CAT: V0	
DOC. NO.	ORDER NO.	INVOICE NO.	INV. DATE	AMOUNT	
812PG029175192 PUBLIC SAFETY-OPERATING		OFFICE OF THE	DIRECTOR	9,780.00	
DATE 01-11-2017			TOTAL AMOUNT	9,780.00	

The State is implementing a new eProcurement system called MissouriBUYS. Check it out at MissouriBUYS.mo.gov and begin registering in August 2015!

Security Features Included B Details on back

**CITY OF FLORISSANT**

955 rue St. Francois  
Phone: 314-921-5700

**APPLICATION FOR LIQUOR LICENSE**

**TYPE OF LICENSE REQUESTED:**

- Full Liquor by the Drink
- Malt Liquor & Wine by the Drink
- Full Liquor by Drink (Non-Profit)
- Full Package Liquor
- Malt Liquor & Wine Package
- Consumption of Liquor
- Tasting

**To the City Clerk, City of Florissant, St. Louis County Missouri:**

The undersigned hereby makes application for a liquor license issued under Chapter 600 of the Florissant City Code

**TYPE OF OPERATION:**

- Individual
- Partnership (Attach list of Partners)
- Corporation - Attach list of officers, addresses, phone no.
- Limited Liability Corp

Name of Business Amore Pizza LLC

Business Address 450 Rue St Francois St Phone (314) 274-8100

Names of Applicant, Corporation, or LLC Amore Pizza LLC

Address of Owner 9815 Traverse St Saint Louis MO 63134 Phone (314) 223-9398  
Street City State Zip

Name of Managing Officer Derick Wellman

Home Address 9815 Traverse Ln Saint Louis MO 63134 Years at address 4  
Street City/State Zip Home Phone N/A

Managing Officer Date & Place of Birth 07/12/64 New Mexico Cell Phone (314) 223-9398

Managing Officer Driver's License No. \_\_\_\_\_ Social Security Number\* \_\_\_\_\_  
(Provide a copy of driver's license) \* Social Security Number will be used for purposes of identification in running record check.

Managing Officer Personal Property Taxes 2016 Paid?  Yes  No (Attach most recent copy)

Managing Officer Register Voter of Missouri?  Yes  No (Attach a Voter Registration Certificate)

Have you ever been arrested?: Yes What Charge? Destruction of Property  
Where? Maryland Heights Disposition? Reimbursement

Citizen of U.S.A.?  Yes  No Naturalized?  Yes  No Date \_\_\_\_\_ ( ) No  
If Naturalized, Give Number: \_\_\_\_\_ Dist. \_\_\_\_\_  
(Provide naturalization documentation)

Do you have an interest in any liquor license which is now in force? NO  
If so, give details \_\_\_\_\_ 2/1/17 at local

Have you previously held a liquor license of any type? NO  
If so, when and where \_\_\_\_\_

Have you ever had a liquor license suspended or revoked? NO  
If so, give details \_\_\_\_\_

Have you ever been convicted of any violation of any federal or state law? NO  
If so, give details \_\_\_\_\_

Have you ever been convicted of any municipal or county ordinance violation? Yes  
If so, give details Dist Destruction of Property

Have you ever been convicted of any violation of a federal law, state statute or local ordinance relating to intoxicating liquor? NO  
If so, give details \_\_\_\_\_

Has the location previously been occupied as a liquor establishment, liquor store or tavern? NO  
If so, state name \_\_\_\_\_

Is the location within 200 feet of property used for church, school or public playground? NO

If Individual Applicant, sign below:

If Partnership, corporation or LLC complete the following:

\_\_\_\_\_

Amore Pizza LLC  
Trade Name \_\_\_\_\_  
[Signature]  
Signature of Managing Officer

STATE OF MISSOURI ) SS  
COUNTY OF ST. LOUIS )

Derick Wellman, of lawful age, being first duly sworn upon his oath  
(Individual or **Managing Officer**)

deposes and states that he/she is the (applicant) (the managing officer of the corporation or partnership seeking the license hereunder), that he/she has read this application and fully understands same, that said license will be subject to all of the ordinances of the City pertaining to the operation of said business and agrees that he will abide by all lawful ordinances, regulations and rules adopted by the City relating to the conduct of said business, that he is in all respect qualified in law to receive such license, and that the answers and statements set out in the above application are true.

[Signature]  
Signature of Individual or **Managing Officer**

Subscribed and sworn to before me this 30 day of January, 2017.

ALICIA M. YATES  
Notary Public - Notary Seal  
STATE OF MISSOURI  
St. Louis County  
My Commission Expires: March 29, 2020  
Commission # 12403957

Alicia M. Yates  
Notary Public

My Commission Expires: March 29, 2020



TO THE CITY CLERK, CITY OF FLORISSANT, ST. LOUIS COUNTY, MISSOURI

**APPLICATION FOR SUNDAY LIQUOR LICENSE**

Authorizing the sale of retail liquor by the drink or package in Florissant on **Sunday** from 9:00 a.m. to Midnight

TYPE OF OPERATION: Individual \_\_\_\_\_ Partnership \_\_\_\_\_ Corporation \_\_\_\_\_ LLC

NAME OF BUSINESS: Amore Pizza LLC

LOCATION: 450 Rue St. Francois St Florissant MO 63031 Telephone: (314) 274-8100

NAME OF APPLICANT (partnership or corporation, give exact trade, LLC or corporate name):  
Amore Pizza LLC

TRADE NAME IF DIFFERENT: \_\_\_\_\_

The undersigned (Individual) (Partnership) (Corporation) (LLC), hereby makes application to the City Clerk, City of Florissant, St. Louis County, Missouri for a By the drink/Package Liquor License authorizing the sale of retail liquor on Sundays from **9:00 a.m. to Midnight** for the period beginning \_\_\_\_\_, and expiring June 30, 20\_\_\_\_, on the above described premises and agrees that if the license herein applied for is granted, and the licensee shall violate any provisions of the State Liquor Control Act or of the Florissant City Code and particularly any provision of Chapter 600 of the Florissant City Code pertaining to alcoholic beverages or permit any other person to do so upon the licensed premises, the City Council, by a majority vote, may suspend or revoke such license.

1) I/WE presently hold License No. \_\_\_\_\_ authorizing the sale of retail liquor by the drink/package in Florissant for premises described in this application.

STATE OF MISSOURI )  
COUNTY OF Florissant )

I/WE Derick Wellman of lawful age, being first duly sworn upon (my) (our) oath(s), name of managing officer ( or owner or partner)

depose and say that (I) (we) have read this application and that (I) (we) fully understand the same; that (I) (we) know the contents thereof and the statements contained therein and that the same are true of (my) (our) own knowledge.

Derick Wellman  
Signature of managing officer (or owner or partner)

SUBSCRIBED AND SWORN TO BEFORE ME THIS 30 DAY OF January 2017

MY COMMISSION EXPIRES March 29, 2020  
Alicia M. Yates  
Notary Public

**ALICIA M. YATES**  
Notary Public - Notary Seal  
STATE OF MISSOURI  
St. Louis County  
My Commission Expires: March 29, 2020  
Commission # 12403957

**SUPPLEMENT TO APPLICATION FOR LIQUOR LICENSE**

**CORPORATION & LIMITED LIABILITY COMPANY:**

Copy of Certificate of Incorporation/ Registration &  
Articles of Organization papers must be attached

To the Florissant City Council,  
Florissant, St. Louis County, Missouri \_\_\_\_\_ DATE \_\_\_\_\_

**TO BE COMPLETED BY ALL PARTNERS, OR IF CORPORATION OR LIMITED  
LIABILITY CORPORATION BY ALL OFFICERS OR MEMBERS:**

1. FULL NAME Derick Wallman  
SOC. SEC. NO. \_\_\_\_\_ PLACE OF BIRTH 712164 ~~St. Louis~~ <sup>Otero County</sup> ~~Mo.~~ <sup>New Mexico</sup>  
DATE OF BIRTH 7/12/64 SEX Male  
PHONE NUMBER (314) 223-9398  
ADDRESS 9815 Traverse Ln Saint Louis, MO 63134  
LAST PREVIOUS ADDRESS 2005 Basston Dr Saint Louis, MO 63146  
NO. OF YRS. 1 1/2 years
  
2. FULL NAME \_\_\_\_\_  
SOC. SEC. NO. \_\_\_\_\_ PLACE OF BIRTH \_\_\_\_\_  
DATE OF BIRTH \_\_\_\_\_ SEX \_\_\_\_\_  
PHONE NUMBER \_\_\_\_\_  
ADDRESS \_\_\_\_\_  
LAST PREVIOUS ADDRESS \_\_\_\_\_  
NO. OF YRS. \_\_\_\_\_
  
3. FULL NAME \_\_\_\_\_  
SOC. SEC. NO. \_\_\_\_\_ PLACE OF BIRTH \_\_\_\_\_  
DATE OF BIRTH \_\_\_\_\_ SEX \_\_\_\_\_  
PHONE NUMBER \_\_\_\_\_  
ADDRESS \_\_\_\_\_  
LAST PREVIOUS ADDRESS \_\_\_\_\_  
NO. OF YRS. \_\_\_\_\_
  
4. FULL NAME \_\_\_\_\_  
SOC. SEC. NO. \_\_\_\_\_ PLACE OF BIRTH \_\_\_\_\_  
DATE OF BIRTH \_\_\_\_\_ SEX \_\_\_\_\_  
PHONE NUMBER \_\_\_\_\_  
ADDRESS \_\_\_\_\_  
LAST PREVIOUS ADDRESS \_\_\_\_\_  
NO. OF YRS. \_\_\_\_\_

**PLEASE FILL OUT THIS FORM AND RETURN WITH YOUR LICENSE APPLICATION**

In order for the Police Department to provide you with the best possible service, it is necessary for them to have certain information concerning your business:

**EMERGENCY INFORMATION**

OWNER OF PROPERTY Ray Bayer PHONE (314) 2568-8457  
ADDRESS 376 Willow Weald Path CITY Chesterfield STATE MO ZIP 63005  
NAME OF BUSINESS Amore Pizza LLC PHONE (314) 274-8100  
ADDRESS 450 Rue St. Francois CITY Florissant STATE MO ZIP 63134  
BUSINESS HOURS 10:30am - 10pm Mon - Sun - Thur 10:30am - 11pm Fri and Sat  
OWNER/MANAGER Derrick Wellman PHONE (314) 223-9398  
HOME ADDRESS 9815 Traverse Ln CITY Saint Louis STATE MO ZIP 63134

**PLEASE LIST PERSONS TO BE CONTACTED AFTER BUSINESS HOURS IN CASE OF AN EMERGENCY OR IF THERE IS A DOOR OR WINDOW FOUND INSECURE.**

CONTACT #1

NAME Derrick Wellman ADDRESS 9815 Traverse Ln  
CITY & STATE Saint Louis, MO ZIP 63134 PHONE (314)  
HAS KEY: YES ( ) NO ( )

CONTACT #2

NAME \_\_\_\_\_ ADDRESS \_\_\_\_\_  
CITY & STATE \_\_\_\_\_ ZIP \_\_\_\_\_ PHONE \_\_\_\_\_  
HAS KEY: YES ( ) NO ( )

ARE THERE LIGHTS LEFT ON AFTER BUSINESS HOURS: YES ( ) NO ( )  
IS ANYONE AUTHORIZED TO BE ON THE PREMISES AFTER BUSINESS HOURS: YES ( ) NO ( )  
IF YES, WHO: Manager clean store for up to an hour after close  
ARE ANY VEHICLES PARKED AT YOUR BUSINESS AFTER HOURS: YES ( ) NO ( )  
DESCRIBE: \_\_\_\_\_  
(YEAR) (MAKE/MODEL) (COLOR) (LICENSE NO.)

DO YOU HAVE A SAFE OF ANY KIND? YES ( ) NO ( )  
IF YES, WHERE IS IT LOCATED: \_\_\_\_\_

CAN IT BE SEEN FROM THE OUTSIDE? YES ( ) NO ( )  
IS YOUR BUSINESS PROTECTED WITH AN ALARM SYSTEM? YES ( ) NO ( )

**IF AT ANY TIME THERE IS A CHANGE IN THE ABOVE INFORMATION, PLEASE NOTIFY THE POLICE DEPARTMENT IMMEDIATELY, ESPECIALLY IN THE CASE OF THOSE PERSONS TO NOTIFY IN CASE OF AN EMERGENCY. THANK YOU.**



*ok / answer*

No Match Notification

A statewide search of the identifiers below has revealed no criminal conviction or sex offender information on file. Fingerprints were not provided and thus the result of the search cannot be guaranteed.

Date of Search: 01/23/2017

Name (1): DERICK WELLMAN

Name (2):

Name (3):

Date Of Birth: 07/12/1964

SSN:

Control Number: 3622443

If you have any questions, please do not hesitate to contact our office at 573-526-6312.

Missouri State Highway Patrol  
Criminal Justice Information Services Division  
PO BOX 9500  
Jefferson City, MO 65102

# CITY OF FLORISSANT

FLORISSANT, MISSOURI

## WAIVER

AUTHORIZATION TO HAVE THE CHIEF OF POLICE OF THE CITY OF FLORISSANT, MISSOURI TO CHECK MY RECORD.

I, Derick Wellman

RESIDING AT 9815 Traverse Ln

IN THE CITY OF Edmundson

STATE MO

DO HEREBY AUTHORIZE THE CITY CLERK OF THE CITY OF FLORISSANT TO MAKE A FULL AND COMPLETE CHECK OF MY RECORD IN THE METROPOLITAN ST. LOUIS AREA, STATE OF MISSOURI, ALL PRIOR AREAS OF RESIDENCE, AND THROUGH THE NATIONAL CRIMINAL INFORMATION CENTER, IN WASHINGTON, D.C.

Quinn Moore  
Witness

Derick Wellman  
Signature

1-23-17  
Date

7-12-64  
Date of Birth

\_\_\_\_\_  
Social Security Number  
Driver's License Number & State

\*\*Social Security Number will be used for identification purposes in running a record check.

# STATE OF MISSOURI



**Jason Kander**  
**Secretary of State**

## CERTIFICATE OF ORGANIZATION

WHEREAS,

*Amore Pizza LLC*  
*LC001468801*

filed its Articles of Organization with this office on the 18th day of November, 2015, and that filing was found to conform to the Missouri Limited Liability Company Act.

NOW, THEREFORE, I, Jason Kander, Secretary of State of the State of Missouri, do by virtue of the authority vested in me by law, do certify and declare that on the 18th day of November, 2015, the above entity is a Limited Liability Company, organized in this state and entitled to any rights granted to Limited Liability Companies.

IN TESTIMONY WHEREOF, I hereunto set my hand and cause to be affixed the GREAT SEAL of the State of Missouri.  
Done at the City of Jefferson, this 18th day of November, 2015.

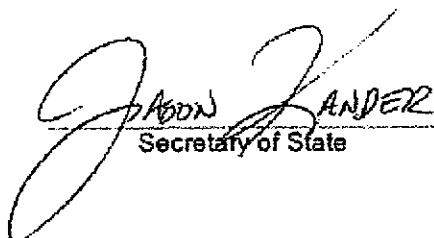
  
Secretary of State

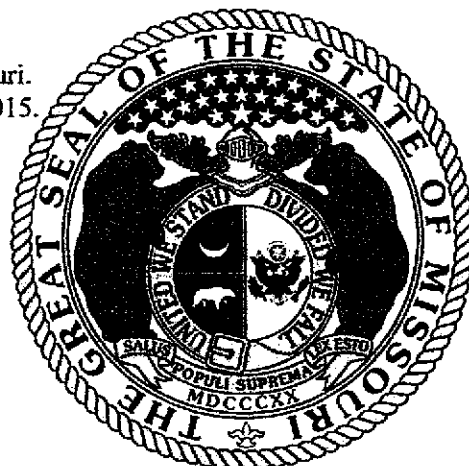

**CITY OF FLORISSANT**

955 rue St. Francois  
Phone: 314-921-5700

**APPLICATION FOR LIQUOR LICENSE**

**TYPE OF LICENSE REQUESTED:**

- Full Liquor by the Drink
- Malt Liquor & Wine by the Drink
- Full Liquor by Drink (Non-Profit)
- Full Package Liquor
- Malt Liquor & Wine Package
- Consumption of Liquor
- Tasting

**To the City Clerk, City of Florissant, St. Louis County Missouri:**

The undersigned hereby makes application for a liquor license issued under Chapter 600 of the Florissant City Code

**TYPE OF OPERATION:**

- Individual
- Partnership (Attach list of Partners)
- Corporation - Attach list of officers, addresses, phone no.
- Limited Liability Corp

Name of Business ALEXANDRIA'S WINE Cellar LLC

Business Address 150 WASHINGTON ST Phone \_\_\_\_\_

Names of Applicant, Corporation, or LLC Jimmie White

Address of Owner 100 WASHINGTON ST, FLORISSANT, MO 63031 Phone 314-921-9498  
Street City State Zip

Name of Managing Officer Jimmie White

Home Address 50 RIVERHAWKS DR FLORISSANT, MO. 63031 Years at address 9  
Street City/State Zip Home Phone 314-831-2513

Managing Officer Date & Place of Birth 8/10/71 SAINT LOUIS Cell Phone 314-497-9445

Managing Officer Driver's License No. \_\_\_\_\_ Social Security Number\* \_\_\_\_\_  
(Provide a copy of driver's license) \* Social Security Number will be used for purposes of identification in running record check.

Managing Officer Personal Property Taxes 2016 Paid?  Yes  No (Attach most recent copy)

Managing Officer Register Voter of Missouri?  Yes  No (Attach a Voter Registration Certificate)

Have you ever been arrested?: NO What Charge? N/A  
Where? N/A Disposition? N/A

Citizen of U.S.A.?  Yes  No Naturalized?  Yes  No Date \_\_\_\_\_ ( ) No  
If Naturalized, Give Number: \_\_\_\_\_ Dist. \_\_\_\_\_  
(Provide naturalization documentation)

Do you have an interest in any liquor license which is now in force? \_\_\_\_\_  
If so, give details \_\_\_\_\_

Have you previously held a liquor license of any type? NO  
If so, when and where \_\_\_\_\_

*Handwritten signature and date:*  
2/21/17  
Clerk to Council  
Alexis Mayo  
Amor

Have you ever had a liquor license suspended or revoked? NO  
If so, give details \_\_\_\_\_

Have you ever been convicted of any violation of any federal or state law? NO  
If so, give details \_\_\_\_\_

Have you ever been convicted of any municipal or county ordinance violation? NO  
If so, give details \_\_\_\_\_

Have you ever been convicted of any violation of a federal law, state statute or local ordinance relating to intoxicating liquor? NO  
If so, give details \_\_\_\_\_

Has the location previously been occupied as a liquor establishment, liquor store or tavern? NO  
If so, state name \_\_\_\_\_

Is the location within 200 feet of property used for church, school or public playground? NO

If Individual Applicant, sign below:

If Partnership, corporation or LLC complete the following:

\_\_\_\_\_

Alexandria's Wine Cellar LLC  
Trade Name  
[Signature]  
Signature of Managing Officer

STATE OF MISSOURI ) SS  
COUNTY OF ST. LOUIS )

Jimmie D White, of lawful age, being first duly sworn upon my f.h.b. oath  
(Individual or **Managing Officer**)

deposes and states that he/she is the (applicant) (the managing officer of the corporation or partnership seeking the license hereunder), that he/she has read this application and fully understands same, that said license will be subject to all of the ordinances of the City pertaining to the operation of said business and agrees that he will abide by all lawful ordinances, regulations and rules adopted by the City relating to the conduct of said business, that he is in all respect qualified in law to receive such license, and that the answers and statements set out in the above application are true.

[Signature]  
Signature of Individual or **Managing Officer**

Subscribed and sworn to before me this 21 day of February, 2017.



J. BRAY  
My Commission Expires  
January 20, 2019  
St. Louis County  
Commission #14502972

[Signature]  
Notary Public J. Bray

My Commission Expires: 1-20-19



TO THE CITY CLERK, CITY OF FLORISSANT, ST. LOUIS COUNTY, MISSOURI

**APPLICATION FOR SUNDAY LIQUOR LICENSE**

Authorizing the sale of retail liquor by the drink or package in Florissant on **Sunday** from 9:00 a.m. to Midnight

TYPE OF OPERATION: Individual \_\_\_\_\_ Partnership  Corporation \_\_\_\_\_ LLC

NAME OF BUSINESS: ALEXANDRIA'S WINE CELLAR LLC

LOCATION: 150 WASHINGTON ST Telephone: 314-497-9145

NAME OF APPLICANT (partnership or corporation, give exact trade, LLC or corporate name):  
ALEXANDRIA'S WINE CELLAR LLC

TRADE NAME IF DIFFERENT: \_\_\_\_\_

The undersigned (Individual) (Partnership) (Corporation) (LLC), hereby makes application to the City Clerk, City of Florissant, St. Louis County, Missouri for a By the drink/Package Liquor License authorizing the sale of retail liquor on Sundays from **9:00 a.m. to Midnight** for the period beginning \_\_\_\_\_, and expiring June 30, 20\_\_\_\_, on the above described premises and agrees that if the license herein applied for is granted, and the licensee shall violate any provisions of the State Liquor Control Act or of the Florissant City Code and particularly any provision of Chapter 600 of the Florissant City Code pertaining to alcoholic beverages or permit any other person to do so upon the licensed premises, the City Council, by a majority vote, may suspend or revoke such license.

1) I/WE presently hold License No. \_\_\_\_\_ authorizing the sale of retail liquor by the drink/package in Florissant for premises described in this application.

STATE OF MISSOURI )SS  
COUNTY OF St. Louis )

I/WE Jimmie D White of lawful age, being first duly sworn upon (my) (our) oath(s), name of managing officer ( or owner or partner)

depose and say that (I) (we) have read this application and that (I) (we) fully understand the same; that (I) (we) know the contents thereof and the statements contained therein and that the same are true of (my) (our) own knowledge.

[Signature]  
Signature of managing officer (or owner or partner)

SUBSCRIBED AND SWORN TO BEFORE ME THIS 21 DAY OF February 2017

MY COMMISSION EXPIRES 1-20-19

[Signature]  
Notary Public J. Bray



J. BRAY  
My Commission Expires  
January 20, 2019  
St. Louis County  
Commission #14502972

**SUPPLEMENT TO APPLICATION FOR LIQUOR LICENSE**

**CORPORATION & LIMITED LIABILITY COMPANY:**

Copy of Certificate of Incorporation/ Registration &  
Articles of Organization papers must be attached

To the Florissant City Council,  
Florissant, St. Louis County, Missouri \_\_\_\_\_ DATE 2-21-17

**TO BE COMPLETED BY ALL PARTNERS, OR IF CORPORATION OR LIMITED LIABILITY CORPORATION BY ALL OFFICERS OR MEMBERS:**

1. FULL NAME Jimmie D White  
SOC. SEC. NO. \_\_\_\_\_ PLACE OF BIRTH SAINT LOUIS  
DATE OF BIRTH 8/10/71 SEX M  
PHONE NUMBER 314-497-9145  
ADDRESS 50 RIVERMEADOWS DR FLORISSANT, MO. 63031  
LAST PREVIOUS ADDRESS 6041 BOULDER CREEK DR HAZELWOOD MO  
NO. OF YRS. 9 63042
  
2. FULL NAME TINA L White  
SOC. SEC. NO. \_\_\_\_\_ PLACE OF BIRTH SAINT LOUIS  
DATE OF BIRTH 12/14/73 SEX F  
PHONE NUMBER 314-707-8326  
ADDRESS 50 RIVERMEADOWS DR FLORISSANT, MO. 63031  
LAST PREVIOUS ADDRESS 6041 BOULDER CREEK DR HAZELWOOD, MO  
NO. OF YRS. 9 63042
  
3. FULL NAME \_\_\_\_\_  
SOC. SEC. NO. \_\_\_\_\_ PLACE OF BIRTH \_\_\_\_\_  
DATE OF BIRTH \_\_\_\_\_ SEX \_\_\_\_\_  
PHONE NUMBER \_\_\_\_\_  
ADDRESS \_\_\_\_\_  
LAST PREVIOUS ADDRESS \_\_\_\_\_  
NO. OF YRS. \_\_\_\_\_
  
4. FULL NAME \_\_\_\_\_  
SOC. SEC. NO. \_\_\_\_\_ PLACE OF BIRTH \_\_\_\_\_  
DATE OF BIRTH \_\_\_\_\_ SEX \_\_\_\_\_  
PHONE NUMBER \_\_\_\_\_  
ADDRESS \_\_\_\_\_  
LAST PREVIOUS ADDRESS \_\_\_\_\_  
NO. OF YRS. \_\_\_\_\_

**PLEASE FILL OUT THIS FORM AND RETURN WITH YOUR LICENSE APPLICATION**

In order for the Police Department to provide you with the best possible service, it is necessary for them to have certain information concerning your business:

**EMERGENCY INFORMATION**

OWNER OF PROPERTY Jimmie D White PHONE 314-497-9145  
ADDRESS 50 Rivermeadows DR CITY Florissant STATE MO ZIP 63031

NAME OF BUSINESS Alexandria's Wine Cellar LLC PHONE \_\_\_\_\_  
ADDRESS 150 Washington St CITY Florissant STATE MO ZIP 63031

BUSINESS HOURS \_\_\_\_\_ SAT 11AM - 11pm / SUN 11AM - 8pm  
OWNER/MANAGER Jimmie & Tina White PHONE \_\_\_\_\_  
HOME ADDRESS 50 Rivermeadows DR CITY Florissant STATE MO ZIP 63031

**PLEASE LIST PERSONS TO BE CONTACTED AFTER BUSINESS HOURS IN CASE OF AN EMERGENCY OR IF THERE IS A DOOR OR WINDOW FOUND INSECURE.**

CONTACT #1  
NAME Jimmie D White ADDRESS 50 Rivermeadows DR  
CITY & STATE Florissant ZIP MO PHONE 63031  
HAS KEY: YES () NO ()

CONTACT #2  
NAME Tina L White ADDRESS 50 Rivermeadows DR  
CITY & STATE Florissant, MO ZIP 63031 PHONE 314-707-8386  
HAS KEY: YES () NO ()

ARE THERE LIGHTS LEFT ON AFTER BUSINESS HOURS: YES () NO ()  
IS ANYONE AUTHORIZED TO BE ON THE PREMISES AFTER BUSINESS HOURS: YES () NO ()  
IF YES, WHO: Jimmie & Tina White  
ARE ANY VEHICLES PARKED AT YOUR BUSINESS AFTER HOURS: YES () NO ()  
DESCRIBE: \_\_\_\_\_  
(YEAR) (MAKE/MODEL) (COLOR) (LICENSE NO.)

DO YOU HAVE A SAFE OF ANY KIND? YES () NO ()  
IF YES, WHERE IS IT LOCATED: \_\_\_\_\_

CAN IT BE SEEN FROM THE OUTSIDE? YES () NO ()  
IS YOUR BUSINESS PROTECTED WITH AN ALARM SYSTEM? YES () NO ()

**IF AT ANY TIME THERE IS A CHANGE IN THE ABOVE INFORMATION, PLEASE NOTIFY THE POLICE DEPARTMENT IMMEDIATELY, ESPECIALLY IN THE CASE OF THOSE PERSONS TO NOTIFY IN CASE OF AN EMERGENCY. THANK YOU.**



## No Match Notification

A statewide search of the identifiers below has revealed no criminal conviction or sex offender information on file. Fingerprints were not provided and thus the result of the search cannot be guaranteed.

Date of Search: 01/11/2017

Name (1): JIMMIE WHITE

Name (2):

Name (3):

Date Of Birth: 08/10/1971

SSN:

Control Number: 3609699

If you have any questions, please do not hesitate to contact our office at 573-526-6312.

Missouri State Highway Patrol  
Criminal Justice Information Services Division  
PO BOX 9500  
Jefferson City, MO 65102

# CITY OF FLORISSANT



FLORISSANT, MISSOURI

## WAIVER

AUTHORIZATION TO HAVE THE CHIEF OF POLICE  
OF THE CITY OF FLORISSANT, MISSOURI TO CHECK MY RECORD.

I, Jimmie D White  
RESIDING AT 50 Rivermeadows Dr  
IN THE CITY OF FLORISSANT  
STATE Missouri

DO HEREBY AUTHORIZE THE CITY CLERK OF THE CITY OF FLORISSANT, MISSOURI  
TO MAKE A FULL AND COMPLETE CHECK OF MY RECORD IN THE METROPOLITAN  
ST. LOUIS AREA, STATE OF MISSOURI, ALL PRIOR AREAS OF RESIDENCE, AND  
THROUGH THE NATIONAL CRIMINAL INFORMATION CENTER, IN WASHINGTON, D.C.

Amto Moon

Witness

R. D. White

Signature

2/21/17

Date

8/10/71

Date of Birth

\_\_\_\_\_  
Social Security Number

\_\_\_\_\_  
Driver's License Number & State  
Provide copy of Driver's License

*\*\* Social Security Number will be used for purposes of identification in running a record check.*

# STATE OF MISSOURI



**Jason Kander**  
**Secretary of State**

## CERTIFICATE OF ORGANIZATION

WHEREAS,

*Alexandria's Wine Cellar LLC*  
*LC001513200*

filed its Articles of Organization with this office on the 4th day of November, 2016, and that filing was found to conform to the Missouri Limited Liability Company Act.

NOW, THEREFORE, I, Jason Kander, Secretary of State of the State of Missouri, do by virtue of the authority vested in me by law, do certify and declare that on the 4th day of November, 2016, the above entity is a Limited Liability Company, organized in this state and entitled to any rights granted to Limited Liability Companies.

IN TESTIMONY WHEREOF, I hereunto set my hand and cause to be affixed the GREAT SEAL of the State of Missouri.  
Done at the City of Jefferson, this 4th day of November, 2016.

  
Secretary of State





**State of Missouri**  
**Jason Kander, Secretary of State**  
 Corporations Division  
 PO Box 778 / 600 W. Main St., Rm. 322  
 Jefferson City, MO 65102

**LC001513200**  
**Date Filed: 11/4/2016**  
**Jason Kander**  
**Missouri Secretary of State**

**Articles of Organization**

*(Submit with filing fee of \$105.00)*

1. The name of the limited liability company is  
Alexandria's Wine Cellar LLC

*(Must include "Limited Liability Company," "Limited Company," "LC," "L.C.," "L.L.C.," or "LLC")*

2. The purpose(s) for which the limited liability company is organized:

The purpose for which the limited liability company is being organized is to operate as a business in the state of Missouri

3. The name and address of the limited liability company's registered agent in Missouri is:

<u>Jimmie D White</u>	<u>50 Rivermeadows Dr</u>	<u>Florissant MO 63031</u>
<i>Name</i>	<i>Street Address: May not use PO Box unless street address also provided</i>	<i>City/State/Zip</i>

4. The management of the limited liability company is vested in:     managers     members    *(check one)*

5. The events, if any, on which the limited liability company is to dissolve or the number of years the limited liability company is to continue, which may be any number or perpetual: Perpetual

*(The answer to this question could cause possible tax consequences, you may wish to consult with your attorney or accountant)*

6. The name(s) and street address(es) of each organizer *(PO box may only be used in addition to a physical street address):*

*(Organizer(s) are not required to be member(s), manager(s) or owner(s))*

<i>Name</i>	<i>Address</i>	<i>City/State/Zip</i>
<u>White, Jimmie D</u>	<u>50 Rivermeadows Dr 50 Rivermeadows Dr</u>	<u>Florissant MO 63031</u>
<u>White, Tina L</u>	<u>50 Rivermeadows Dr 50 Rivermeadows Dr</u>	<u>Florissant MO 63031</u>

7.  Series LLC (OPTIONAL) Pursuant to Section 347.186, the limited liability company may establish a designated series in its operating agreement. The names of the series must include the full name of the limited liability company and are the following:

New Series:

The limited liability company gives notice that the series has limited liability.

New Series:

The limited liability company gives notice that the series has limited liability.

New Series:

The limited liability company gives notice that the series has limited liability.

*(Each separate series must also file an Attachment Form LLC 1A.)*

Name and address to return filed document:

Name: Jimmie D White

Address: Email: qahs.cds.jwhite@gmail.com

City, State, and Zip Code: \_\_\_\_\_

8. The effective date of this document is the date it is filed by the Secretary of State of Missouri unless a future date is otherwise indicated: \_\_\_\_\_  
(Date may not be more than 90 days after the filing date in this office)

In Affirmation thereof, the facts stated above are true and correct:

(The undersigned understands that false statements made in this filing are subject to the penalties provided under Section 575.040, RSMo)

All organizers must sign

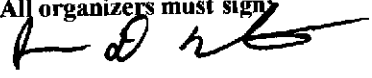

Jimmie D White  
*Organizer Signature*

JIMMIE D WHITE  
*Printed Name*

11/04/2016  
*Date of Signature*

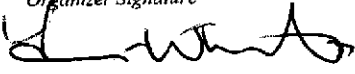

Tina L White  
*Organizer Signature*

TINA L WHITE  
*Printed Name*

11/04/2016  
*Date of Signature*



STATE OF MISSOURI  
COUNTY OF ST. LOUIS

The foregoing document was acknowledged before me this 4th day of November, 2016 by  
Jimmie D. White and Tina L. White, husband and wife.

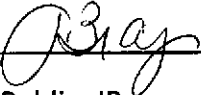
  
\_\_\_\_\_  
Notary Public: JBray

Expires: 1/20/19



J. BRAY  
My Commission Expires  
January 20, 2019  
St. Louis County  
Commission #14502972

1 INTRODUCED BY COUNCILMAN SIAM  
2 FEBRUARY 28, 2017

3  
4 BILL NO. 9263

ORDINANCE NO.

5  
6 **ORDINANCE TO AUTHORIZE AN AMENDMENT TO SPECIAL USE**  
7 **PERMIT NO. 8029 TO BURGER KING TO ALLOW FOR**  
8 **RENOVATIONS TO THE EXISTING BUILDING IN A B-3 ZONING**  
9 **DISTRICT FOR THE PROPERTY LOCATED AT 3121 N. HIGHWAY 67.**

10  
11 WHEREAS, the Florissant Zoning Ordinance authorizes the City Council of the City of  
12 Florissant, by Special Use Permit, after public hearing thereon, to permit the location and  
13 operation of a restaurant; and

14 WHEREAS, the Florissant City Council has heretofore granted a Special Use Permit to  
15 Cross Keys Restaurant Group, LLC d/b/a Burger King for the location and operation of a  
16 restaurant on the property described in Ordinance No. 8029; and

17 WHEREAS, an application has been filed by Broadway Restaurant Group, LLC for an  
18 amendment to the said Special Use Permit heretofore granted under Ordinance No. 8029 to  
19 authorize the addition of certain conditions; and

20 WHEREAS, the Planning and Zoning Commission of the City of Florissant at their  
21 meeting of February 6th, 2017 has recommended that the said Special Use Permit be amended;  
22 and

23 WHEREAS, due notice of public hearing no. 17-02-005 on said application to be held on  
24 the 28th day of February, 2017 at 7:30 P.M. by the Council of the City of Florissant was duly  
25 published, held and concluded; and

26 WHEREAS, the Council, following said public hearing, and after due and careful  
27 consideration, has concluded that the granting of an amendment to the Special Use Permit  
28 authorized by Ordinance No. 8029, as hereinafter provided would be in the best interest of the  
29 City of Florissant.

30 NOW, THEREFORE, BE IT ORDAINED BY THE COUNCIL OF THE CITY OF  
31 FLORISSANT, ST. LOUIS COUNTY, MISSOURI, AS FOLLOWS:

32  
33 Section 1: The Special Use Permit heretofore granted to amend Special  
34 Use Permit No. 8029, 3121 N Highway 67 (Burger King), to allow for renovations to a  
35 sit-down, carry-out and drive thru restaurant in a B-3 Extensive Business District, as  
36 depicted on the application documents: ST1, A1, A2.1 and A2.2 all dated 1/12/17 as  
37 prepared by Tevis Architects, subject to regulations in the B-3 Extensive Business  
38 District, with the following conditions:

- 39 No painted brick
- 40 Screening of RTU unit
- 41 Bollards on the east side of the patio

1. GENERAL DEVELOPMENT CONDITIONS.

a. Unless, and except to the extent, otherwise specifically provided in Ordinance No. 8029, development shall be effected only in accordance with all ordinances of the City of Florissant.

2. PROJECT COMPLETION.

Construction shall start within 90 days of the issuance of building permits for the project and shall be developed in accordance of the approved final development plan within 180 days of start of construction.

Section 2: Said Special Permit shall be conditioned on and shall remain in full force and effect so long as the conditions set out in Ordinance no. 7398, as now amended, are adhered to.

Section 3: This ordinance shall become in force and effect immediately upon its passage and approval.

Adopted this \_\_\_\_ day of \_\_\_\_\_, 2017.

\_\_\_\_\_  
 Jackie Pagano  
 President of the Council  
 City of Florissant

Approved this \_\_\_\_ day of \_\_\_\_\_, 2017.

\_\_\_\_\_  
 Thomas P. Schneider  
 Mayor, City of Florissant

ATTEST:

\_\_\_\_\_  
 Karen Goodwin, MMC/MRCC  
 City Clerk

1 INTRODUCED BY COUNCILMAN EAGAN  
2 FEBRUARY 28, 2017

3  
4  
5 BILL NO. 9264

ORDINANCE NO.

6  
7  
8 **AN ORDINANCE GRANTING A SPECIAL USE PERMIT TO STL**  
9 **HOWDERSHELL, LLC D/B/A ST. LOUIS FISH AND CHICKEN TO ALLOW**  
10 **FOR THE OPERATION OF A CARRY-OUT RESTAURANT FOR THE**  
11 **PROPERTY LOCATED AT 340-A HOWDERSHELL ROAD.**

12  
13 WHEREAS, the Florissant Zoning Ordinance authorizes the City Council of the City of  
14 Florissant, by Special Use Permit, after public hearing thereon, to permit the location of a restaurant; and

15 WHEREAS, an application has been filed by STL Howdershell d/b/a St. Louis Fish and  
16 Chicken for the property located at 340-A Howdershell for the location and operation of a carry-out  
17 restaurant; and

18 WHEREAS, the Planning and Zoning Commission of the City of Florissant, at their meeting of  
19 February 6, 2017 has recommended that the said Special Use Permit be granted; and

20 WHEREAS, due notice of a public hearing no. 17-02-006 said application to be held on the 28<sup>th</sup>  
21 day of February, 2017 at 7:30 P.M. by the Council of the City of Florissant was duly published, held and  
22 concluded; and

23 WHEREAS, the Council, following said public hearing, and after due and careful consideration,  
24 has concluded that the granting of the Special Use Permit as hereinafter provided would be in the best  
25 interest of the City of Florissant.

26 NOW, THEREFORE, BE IT ORDAINED BY THE COUNCIL OF THE CITY OF  
27 FLORISSANT, ST. LOUIS COUNTY, MISSOURI, AS FOLLOWS:

28  
29 Section I: A Special Use Permit is hereby granted to STL Howdershell, LLC d/b/a St. Louis Fish  
30 and Chicken for the property located at 340-A Howdershell to allow for a carry-out restaurant in a B-5  
31 Zoning District as depicted on the application documents: CS and A1.0 dated 1/25/17 as prepared by  
32 Deru & Associates, LLC subject to the regulations in a B-5 Planned Commercial District and the  
33 following additional requirements:

34  
35 **1. GENERAL DEVELOPMENT CONDITIONS.**

- 36 a. Unless, and except to the extent otherwise specifically provided herein, development shall  
37 be effected only in accordance with all ordinances of the City of Florissant.

38  
39  
40  
41  
42  
43  
44  
45  
46  
47  
48  
49  
50  
51  
52  
53  
54  
55  
56  
57  
58  
59  
60  
61  
62  
63  
64  
65  
66  
67  
68  
69  
70  
71  
72

**2. PROJECT COMPLETION.**

Construction shall start within 90 days of the issuance of building permits for the project and shall be developed in accordance of the approved final development plan within 180 days of start of construction.

Section 2: When the named permittee discontinues the operation of said business, the Special Use Permit herein granted shall no longer be in force and effect.

Section 3: This ordinance shall become in force and effect immediately upon its passage and approval.

Adopted this \_\_\_\_\_ day of \_\_\_\_\_, 2017.

\_\_\_\_\_  
Jackie Pagano  
President of the Council  
City of Florissant

Approved this \_\_\_\_\_ day of \_\_\_\_\_, 2017.

\_\_\_\_\_  
Thomas P. Schneider  
Mayor, City of Florissant

ATTEST:

\_\_\_\_\_  
Karen Goodwin, MMC/MRCC  
City Clerk

1 INTRODUCED BY COUNCILMAN HENKE  
2 FEBRUARY 28, 2017

3  
4 BILL NO. 9265

ORDINANCE NO.

5  
6 **AN ORDINANCE AUTHORIZING THE RE-PAINTING OF MASONRY**  
7 **FOR CHURCH’S CHICKEN LOCATED AT 410 N. HIGHWAY 67.**  
8

9 Whereas, section 500.040 states that “Re-painting for reasons other than for maintenance  
10 of current painted surfaces upon the approval of the Director of Public Works and requests to  
11 change the color or texture of the existing brick or masonry surface, may not be done without the  
12 review and recommendation from Planning and Zoning Commission and approval of City  
13 Council.”; and

14 Whereas, Camelot Facility Management Solutions represented ty Arminda L. Mills for  
15 Church’s Chicken is proposing to re-paint the brick on the building located at 410 N. Hwy 67 the  
16 brick for reasons other than for maintenance; and

17 Whereas, The City Council believes finds that it is appropriate under these circumstances  
18 to allow Church’s Chicken to repaint the brick.

19  
20 BE IT ORDAINED BY THE COUNCIL OF THE CITY OF FLORISSANT, ST. LOUIS  
21 COUNTY, MISSOURI, AS FOLLOWS:

22  
23 Section 1: Church’s Chicken is hereby authorized to re-paint the brick in accordance  
24 with the elevations submitted 2/13/17 and labeled #616 Florissant, MO attached hereto.

25 Section 2: This ordinance shall become in force and effect immediately upon its passage  
26 and approval.

27 Adopted this \_\_\_\_\_ day of \_\_\_\_\_, 2017.

28  
29 \_\_\_\_\_  
30 Jackie Pagano  
31 President of the Council  
32 City of Florissant

33 Approved this \_\_\_\_\_ day of \_\_\_\_\_, 2017.

34  
35 \_\_\_\_\_  
36 Thomas P. Schneider  
37 Mayor, City of Florissant

38 ATTEST:

39  
40 \_\_\_\_\_  
41 Karen Goodwin, MMC/MRCC  
42 City Clerk  
43

**From:** Philip Lum [mailto:plum@florissantmo.com]  
**Sent:** Monday, February 13, 2017 9:43 AM  
**To:** Arminda Mills <Amills@camelotservices.com>  
**Cc:** Aaron Tossey <atossey@florissantmo.com>  
**Subject:** RE: Unit 616 - New Paint Scheme

Please submit 9 copies to the city clerk for approval of painting masonry.

**Philip E. Lum, AIA**  
Building Commissioner  
955 Rue St. Francois  
Florissant, MO 63031  
314-839-7642  
[plum@florissantmo.com](mailto:plum@florissantmo.com)

---

**From:** Arminda Mills [mailto:Amills@camelotservices.com]  
**Sent:** Monday, February 13, 2017 8:54 AM  
**To:** Aaron Tossey; Philip Lum  
**Subject:** FW: Unit 616 - New Paint Scheme

Good Morning Mr. Lum and Mr. Tossey

Attached is the proposed color scheme for the Church's in Florissant. Please take a look and let me know if there is anything else that I or Church's may need to provide so that we may gain approval to move forward with the color change. As soon as I know that the colors and scheme have been approved we will move forward painting.

Thank you,

*Arminda L. Mills*  
Property Administrator

**Camelot Facility Management Solutions**  
5600 Tennyson Parkway, Ste. 370  
Plano, TX 75024  
Phone: (214) 233-7563  
Fax: (214) 473-8999  
**After Hours Emergency Service Line: 1(866) 203-2176**  
Email: [amills@camelotservices.com](mailto:amills@camelotservices.com)  
Website: [www.camelotservices.com](http://www.camelotservices.com)

Stephen M. Maurillo  
Director, Real Estate Attorney  
**Cajun Operating Company**  
**d/b/a Church's Chicken and**  
**Texas Chicken**  
980 Hammond Drive, NE  
Suite 1100  
Atlanta, Georgia 30328  
Phone: (770) 512-3993  
Fax: (770) 512-3925

Email: [smaurillo@churchs.com](mailto:smaurillo@churchs.com)  
Website: [www.churchs.com](http://www.churchs.com)  
Private and Confidential - Do Not Copy



---

CONFIDENTIALITY NOTICE: This e-mail contains information that is confidential, proprietary or legally privileged and is the property of Cajun Operating Company. If you are not the proper recipient of this e-mail, please delete this message and notify the sender immediately via a separate e-mail or call 770-350-3800.

**CONFIDENTIALITY NOTICE: This e-mail contains information that is confidential, proprietary or legally privileged and is the property of Cajun Operating Company. If you are not the proper recipient of this e-mail, please delete this message and notify the sender immediately via a separate e-mail or call 770-350-3800**





- Tower panels to be painted: Anonymous SW7046
- Roof trim to be painted: Urbane Bronze SW7048
- Upper walls to be painted: Urban Putty SW7532
- Trim to be painted: Goldenrod SW6677
- Lower walls to be painted: Urbane Bronze SW7048



FRONT/RIGHT



Exterior Colors	Sherwin Williams
Tower	SW 7046 Anonymous
Upper Wall	SW 7532 Urban Putty
Band	SW 6677 Goldenrod
Crown Roof & Lower Wall	SW 7048 Urbane Bronze



REAR

- Crown Roof
- Tower
- Upper Wall
- Trim Band
- Lower Wall



#616 Florissant, MO  
WARM GREYS